



The Seventy-Six

Parcel 76, 76 Second
Avenue, City of Albany, NY

Owner: South End Development
LLC

Architect:
Garrison-Architects
45 Main Street
Brooklyn, NY 11201

SCHEMATIC DESIGN

Date: 6/22/2020
Project No: 2005

Cover Sheet

AG-001

The Seventy-Six

Parcel 76, 76 Second Avenue, City of Albany,
NY

Owner: **South End Development
LLC**

Architect:
Garrison-Architects
45 Main Street
Brooklyn, NY 11201

Revision Schedule

Revision Number	Revision Description	Revision Date
--------------------	-------------------------	------------------

SCHEMATIC DESIGN

Scale: AS NOTED
Date: 6/22/2020
Project No: 2005
Drawn by:
Checked by:

Seal & Signature:

DOB Stamp & Signature

DOB Scan:

Drawing Title:

Drawing List

Drawing Number:

AG-002

DWG.No: of

DRAWING LIST	
Sheet Number	Sheet Title
AG-001	Cover Sheet
AG-002	Drawing List
C-001	Notes & Legends
C-110	Master Plan
C-111	Alternate Master Plan
C-120	Demolition Plan
C-130	Site Layout Plan
C-140	Grading & Drainage Plan
C-150	Erosion & Sediment Control Plan
C-160	Utility Date
C-180	Landscaping Plan
C-190	Delivery Truck Maneuvering Plan
C-191	Passenger Car Maneuvering Plan
C-500	Erosion & Sediment Control Details
C-501	Site Details
C-502	Site Details
C-503	Storm Sewer Details
C-504	Stormwater Management Details
C-505	Water System Details
C-506	Sanitary Sewer System Details
C-507	Landscaping Details & Notes
C-508	Work Zone Traffic Control Details & Notes
AA-101	Overall Floor Plans
AA-102	Overall Floor Plans
AA-103	Overall Floor Plans
AA-104	Overall Floor Plans
AA-105	Overall Floor Plans
AA-106	Overall Floor Plans
AA-107	Overall Floor Plans
AA-201	Elevations - SITE
AA-202	Elevations - BLDG A - North South
AA-203	Elevations - BLDG A - East West
AA-204	Elevations - BLDG B - North South
AA-205	Elevations - BLDG B - East West
AA-206	Elevations - BLDG C - North South
AA-207	Elevations - BLDG C - East West
AA-208	Elevations - BLDG D - North South
AA-209	Elevations - BLDG D - East West



THE SEVENTY-SIX

Parcel 76, 76 Second Avenue, City of Albany, NY

Owner: South End Development LLC

Architect:
Garrison-Architects
45 Main Street
Brooklyn, NY 11201

Civil Engineer:
The Chazen Companies
547 River St.
Troy, NY 12180
p (518) 273-0055
Chazen Project No. 32019.00

Revision Schedule

Revision Number	Revision Description	Revision Date

Schematic Design

Scale: AS NOTED
 Date: 06/23/2020
 Project No: 2005
 Drawn by: KC/SM
 Checked by: RK

Seal & Signature:

DOB Stamp & Signature

DOB Scan:

Drawing Title:
Master Plan

Drawing Number:
C-110

DWG.No:



THE SEVENTY-SIX

Parcel 76, 76 Second Avenue, City of Albany, NY

Owner: South End Development LLC

Architect:
Garrison-Architects
45 Main Street
Brooklyn, NY 11201

Civil Engineer:
The Chazen Companies
547 River St.
Troy, NY 12180
p (518) 273-0055
Chazen Project No. 32019.00

Revision Schedule

Revision Number	Revision Description	Revision Date

Schematic Design

Scale: AS NOTED
 Date: 07/21/2020
 Project No: 2005
 Drawn by: KC/SM
 Checked by: RK

Seal & Signature:

DOB Stamp & Signature

DOB Scan:

Drawing Title:

Alternate Master Plan

Drawing Number:

C-111

DWG.No:

THE SEVENTY-SIX

Parcel 76, 76 Second Avenue, City of Albany, NY

Owner: South End Development LLC

Architect:
Garrison-Architects
45 Main Street
Brooklyn, NY 11201

Civil Engineer:
The Chazen Companies
547 River St.
Troy, NY 12180
p (518) 273-0055
Chazen Project No. 32019.00

Revision Schedule

Revision Number	Revision Description	Revision Date

Schematic Design

Scale: AS NOTED
Date: 06/23/2020
Project No: 2005
Drawn by: KC/SM
Checked by: RK

Seal & Signature:

DOB Stamp & Signature

DOB Scan:

Drawing Title:
Demolition Plan

Drawing Number:

C-120

DWG.No:

KEYED NOTES:

- 1 EXISTING PROPERTY LINE TO BE REMOVED, AS PART OF LOT CONSOLIDATION.
- 2 EXISTING BUILDING TO BE DEMOLISHED UNDER SEPARATE CONTRACT.
- 3 EXISTING ACCESSORY STRUCTURE TO BE DEMOLISHED UNDER SEPARATE CONTRACT.
- 4 SAWCUT CLEAN EDGE IN ASPHALT PAVEMENT, CUT 18" MINIMUM FROM EXISTING OR PROPOSED CURB FACE.
- 5 EXISTING ASPHALT PAVEMENT SECTION AND SUBBASE TO BE REMOVED TO DEPTH OF NEW CONSTRUCTION.
- 6 EXISTING ASPHALT WING CURB TO BE REMOVED.
- 7 EXISTING GRANITE CURB TO BE REMOVED. AT LIMIT OF CURB REMOVAL, REMOVE TO NEAREST JOINT. SALVAGE AND REUSE ALL GRANITE CURB IN GOOD CONDITION.
- 8 EXISTING CONCRETE SIDEWALK TO BE REMOVED. AT LIMIT OF SIDEWALK REMOVAL, REMOVE TO NEAREST CONSTRUCTION JOINT.
- 9 EXISTING CONCRETE PAD AND/OR PAVERS TO BE REMOVED.
- 10 EXISTING RETAINING WALL AND FOUNDATION TO BE REMOVED.
- 11 EXISTING DECK, STAIR, RAILING AND LANDING TO BE REMOVED.
- 12 EXISTING FENCE, AND FENCE POSTS TO BE REMOVED IN ENTIRETY.
- 13 EXISTING TREES TO BE REMOVED IN ENTIRETY.
- 14 EXISTING SIGN AND POST TO BE REMOVED IN ENTIRETY.
- 15 EXISTING SIGN AND POST TO BE REMOVED AND RELOCATED.
- 16 EXISTING OVERHEAD TELEPHONE LINES, POWER LINES, UTILITY POLES WITH APPURTENANCES, AND STREET LIGHTS TO BE REMOVED. CONTRACTOR TO COORDINATE WITH UTILITIES PROVIDER PRIOR TO REMOVAL AND CONFIRM ALL LINES HAVE BEEN DE-ENERGIZED.
- 17 EXISTING ELECTRICAL STRUCTURE TO BE REMOVED. COORDINATE WITH UTILITY PROVIDER FOR TERMINATION.
- 18 EXISTING ELECTRICAL LINES TO BE REMOVED. CONTRACTOR TO REFER TO ARCHITECTURAL AND MEP PLANS FOR DETAILED ELECTRICAL LAYOUT AND DESIGN.
- 19 EXISTING FIRE HYDRANT, VALVE AND SERVICE TO REMAIN AND BE PROTECTED THROUGHOUT CONSTRUCTION.
- 20 EXISTING WATER MAIN TO BE REMOVED. COORDINATE WITH CITY OF ALBANY DEPARTMENT OF WATER AND WATER SUPPLY.
- 21 EXISTING UTILITY STRUCTURE TO REMAIN AND BE PROTECTED THROUGHOUT CONSTRUCTION. CONTRACTOR TO ADJUST STRUCTURE AND TF/RIM ELEVATION AS REQUIRED TO MATCH FINISHED GRADE.
- 22 EXISTING POOL TO BE REMOVED

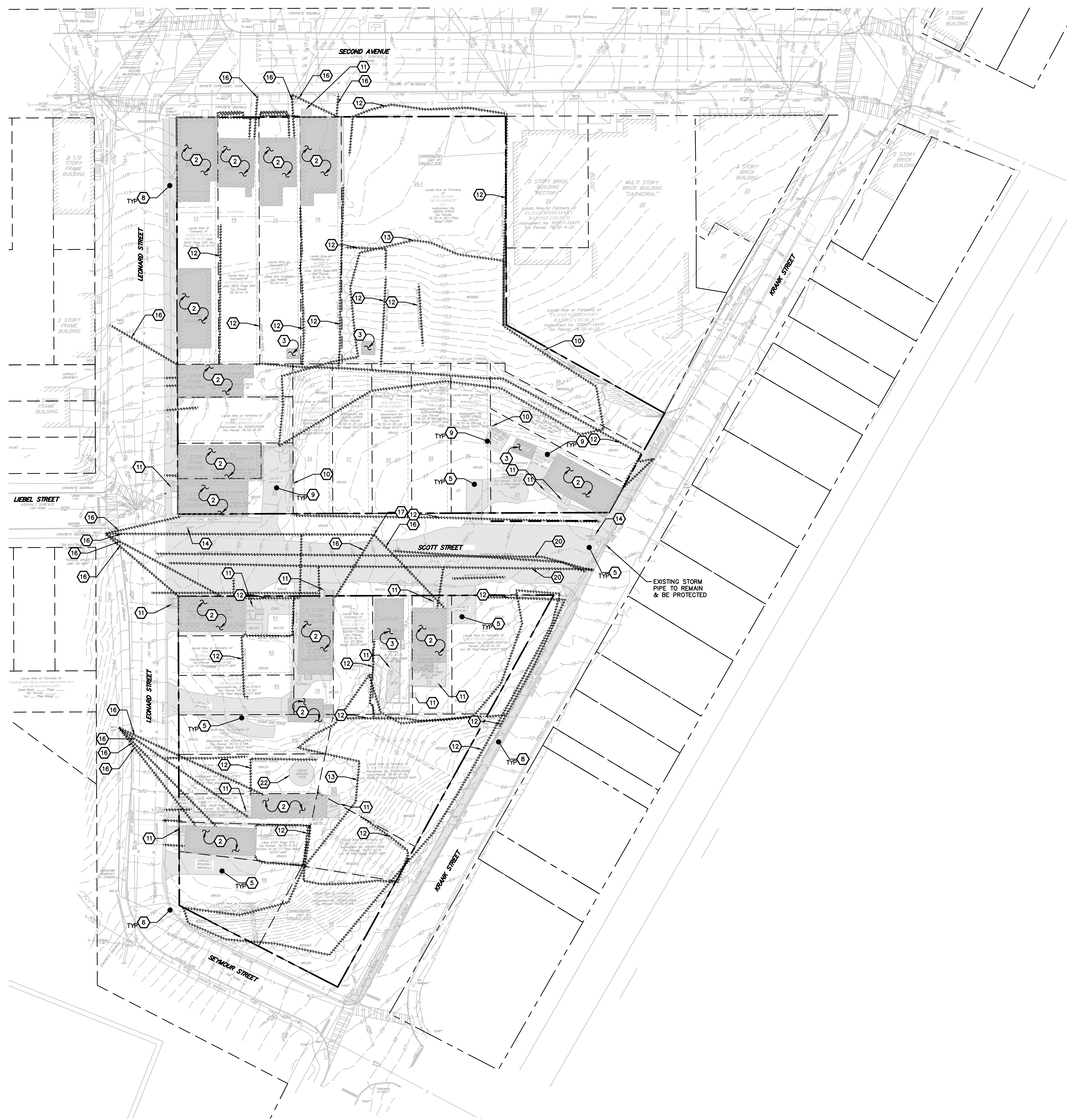

THE SEVENTY-SIX

Parcel 76, 76 Second Avenue, City of Albany, NY

Owner: South End Development LLC

Architect:
Garrison-Architects
45 Main Street
Brooklyn, NY 11201

Civil Engineer:
The Chazen Companies
547 River St.
Troy, NY 12180
p (518) 273-0055
Chazen Project No. 32019.00

Revision Schedule

Revision Number	Revision Description	Revision Date
-----------------	----------------------	---------------

Schematic Design

Scale: AS NOTED
Date: 06/23/2020
Project No: 2005
Drawn by: KC/SM
Checked by: RK

Seal & Signature:

DOB Stamp & Signature

DOB Scan:

Drawing Title:

Site Layout Plan

Drawing Number:

C-130

DWG.No:

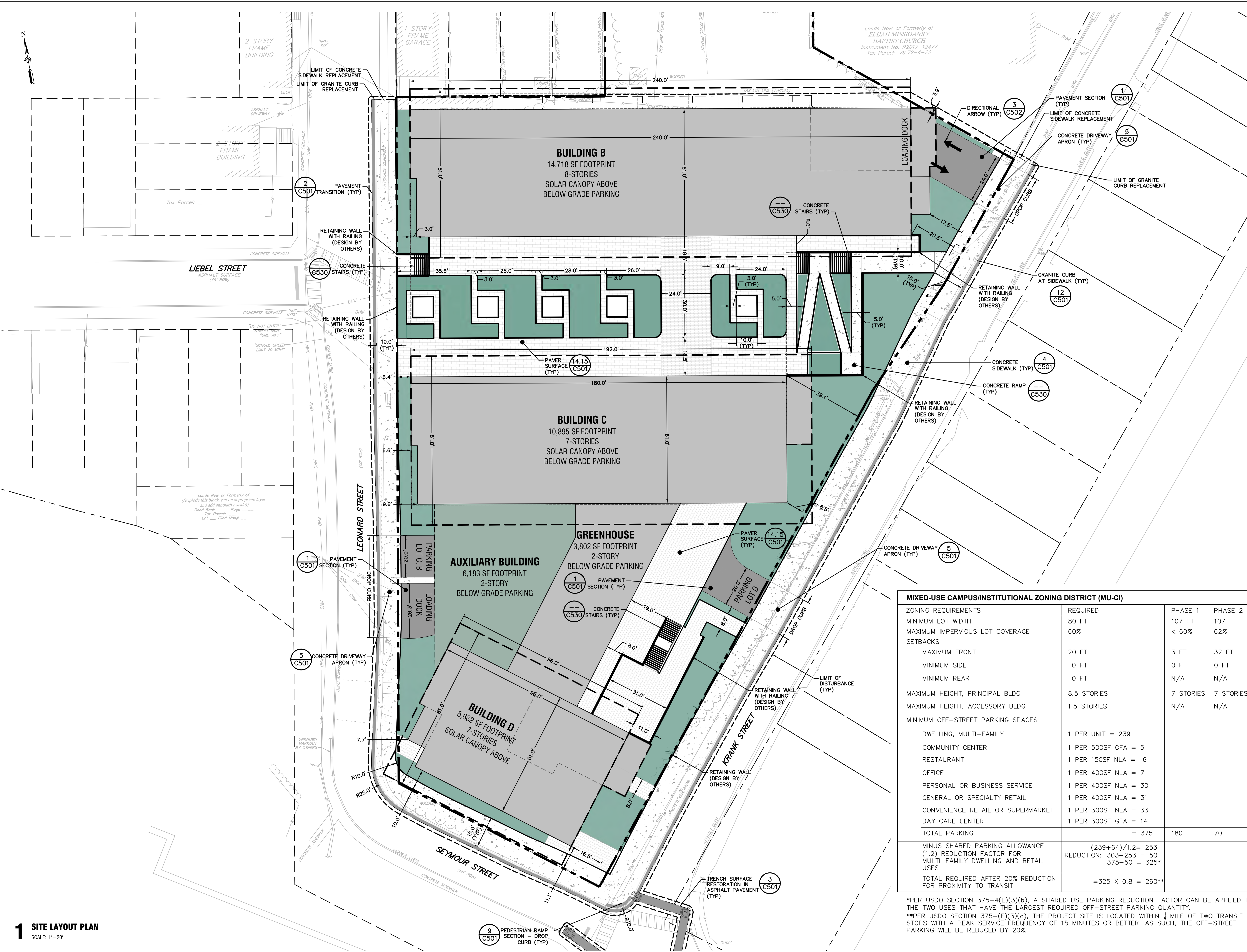

MIXED-USE CAMPUS/INSTITUTIONAL ZONING DISTRICT (MU-CI)			
ZONING REQUIREMENTS	REQUIRED	PHASE 1	PHASE 2
MINIMUM LOT WIDTH	80 FT	107 FT	107 FT
MAXIMUM IMPERVIOUS LOT COVERAGE	60%	< 60%	62%
SETBACKS			
MAXIMUM FRONT	20 FT	3 FT	32 FT
MINIMUM SIDE	0 FT	0 FT	0 FT
MINIMUM REAR	0 FT	N/A	N/A
MAXIMUM HEIGHT, PRINCIPAL BLDG	8.5 STORIES	7 STORIES	7 STORIES
MAXIMUM HEIGHT, ACCESSORY BLDG	1.5 STORIES	N/A	N/A
MINIMUM OFF-STREET PARKING SPACES			
DWELLING, MULTI-FAMILY	1 PER UNIT = 239		
COMMUNITY CENTER	1 PER 500SF GFA = 5		
RESTAURANT	1 PER 150SF NLA = 16		
OFFICE	1 PER 400SF NLA = 7		
PERSONAL OR BUSINESS SERVICE	1 PER 400SF NLA = 30		
GENERAL OR SPECIALTY RETAIL	1 PER 400SF NLA = 31		
CONVENIENCE RETAIL OR SUPERMARKET	1 PER 300SF NLA = 33		
DAY CARE CENTER	1 PER 300SF GFA = 14		
TOTAL PARKING	= 375	180	70
MINUS SHARED PARKING ALLOWANCE (1.2) REDUCTION FACTOR FOR MULTI-FAMILY DWELLING AND RETAIL USES	(239+64)/1.2= 253 REDUCTION: 303-253 = 50 375-50 = 325*		
TOTAL REQUIRED AFTER 20% REDUCTION FOR PROXIMITY TO TRANSIT	= 325 X 0.8 = 260**		

*PER USDO SECTION 375-4(E)(3)(b), A SHARED USE PARKING REDUCTION FACTOR CAN BE APPLIED TO THE TWO USES THAT HAVE THE LARGEST REQUIRED OFF-STREET PARKING QUANTITY.
**PER USDO SECTION 375-E(3)(e), THE PROJECT SITE IS LOCATED WITHIN 1/4 MILE OF TWO TRANSIT STOPS WITH A PEAK SERVICE FREQUENCY OF 15 MINUTES OR BETTER. AS SUCH, THE OFF-STREET PARKING WILL BE REDUCED BY 20%.

1 SITE LAYOUT PLAN
SCALE: 1"=20'

THE SEVENTY-SIX

Parcel 76, 76 Second Avenue, City of Albany, NY

Owner: South End Development LLC

Architect:
Garrison-Architects
45 Main Street
Brooklyn, NY 11201

Civil Engineer:
The Chazen Companies
547 River St.
Troy, NY 12180
p (518) 273-0055
Chazen Project No. 32019.00

Revision Schedule

Revision Number	Revision Description	Revision Date
-----------------	----------------------	---------------

Schematic Design

Scale: AS NOTED
Date: 06/23/2020
Project No: 2005
Drawn by: KC/SM
Checked by: RK

Seal & Signature:

DOB Stamp & Signature

DOB Scan:

Drawing Title:
Grading & Drainage Plan

Drawing Number:

C-140

DWG.No:

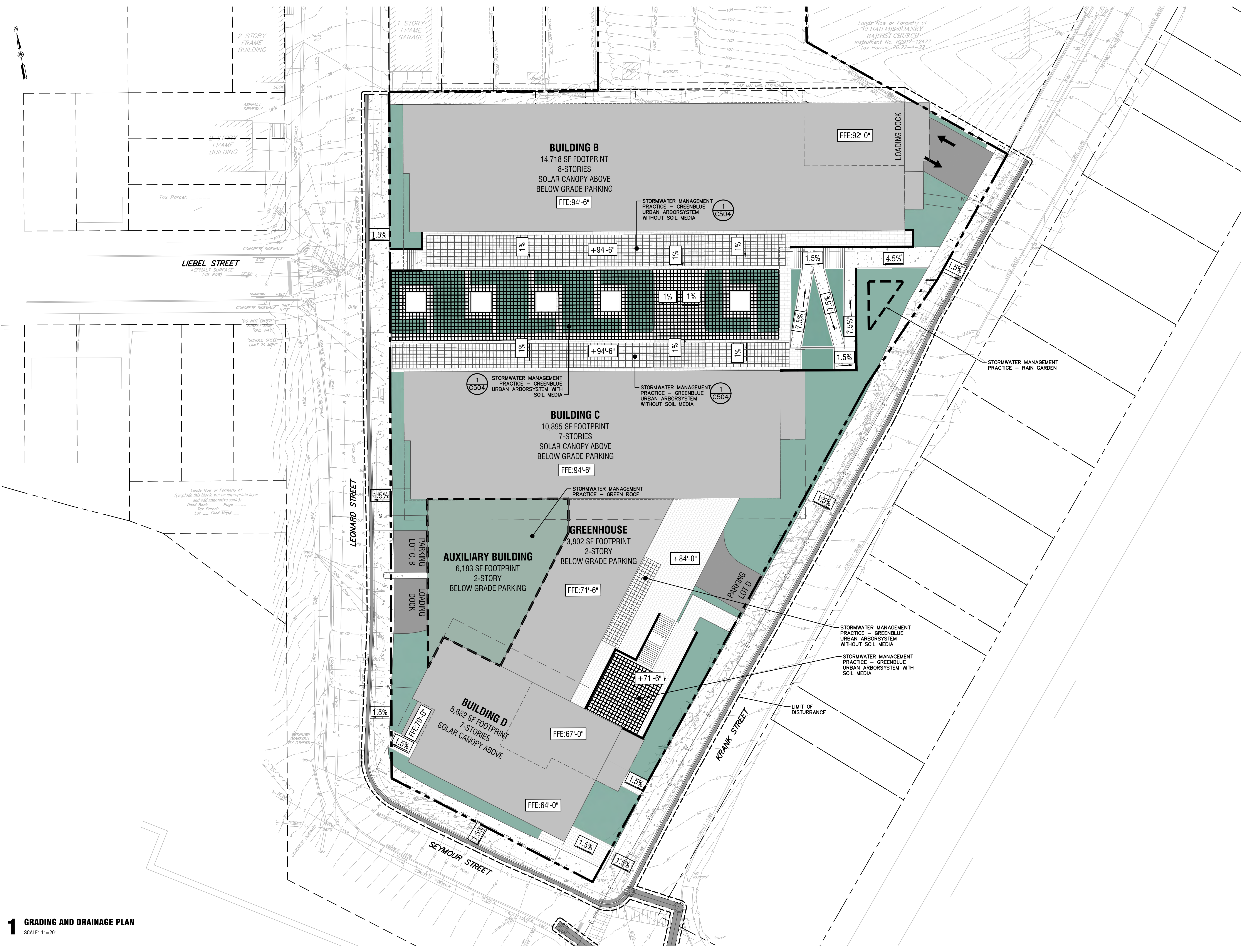

THE SEVENTY-SIX

Parcel 76, 76 Second Avenue, City of Albany, NY

Owner: South End Development LLC

Architect:
Garrison-Architects
45 Main Street
Brooklyn, NY 11201

Civil Engineer:
The Chazen Companies
547 River St.
Troy, NY 12180
p (518) 273-0055
Chazen Project No. 32019.00

Revision Schedule

Revision Number	Revision Description	Revision Date
-----------------	----------------------	---------------

Schematic Design

Scale: AS NOTED
Date: 06/23/2020
Project No: 2005
Drawn by: KC/SM
Checked by: RK

Seal & Signature:

DOB Stamp & Signature

DOB Scan:

Drawing Title:
Erosion & Sediment Control Plan

Drawing Number:

C-150

DWG.No:

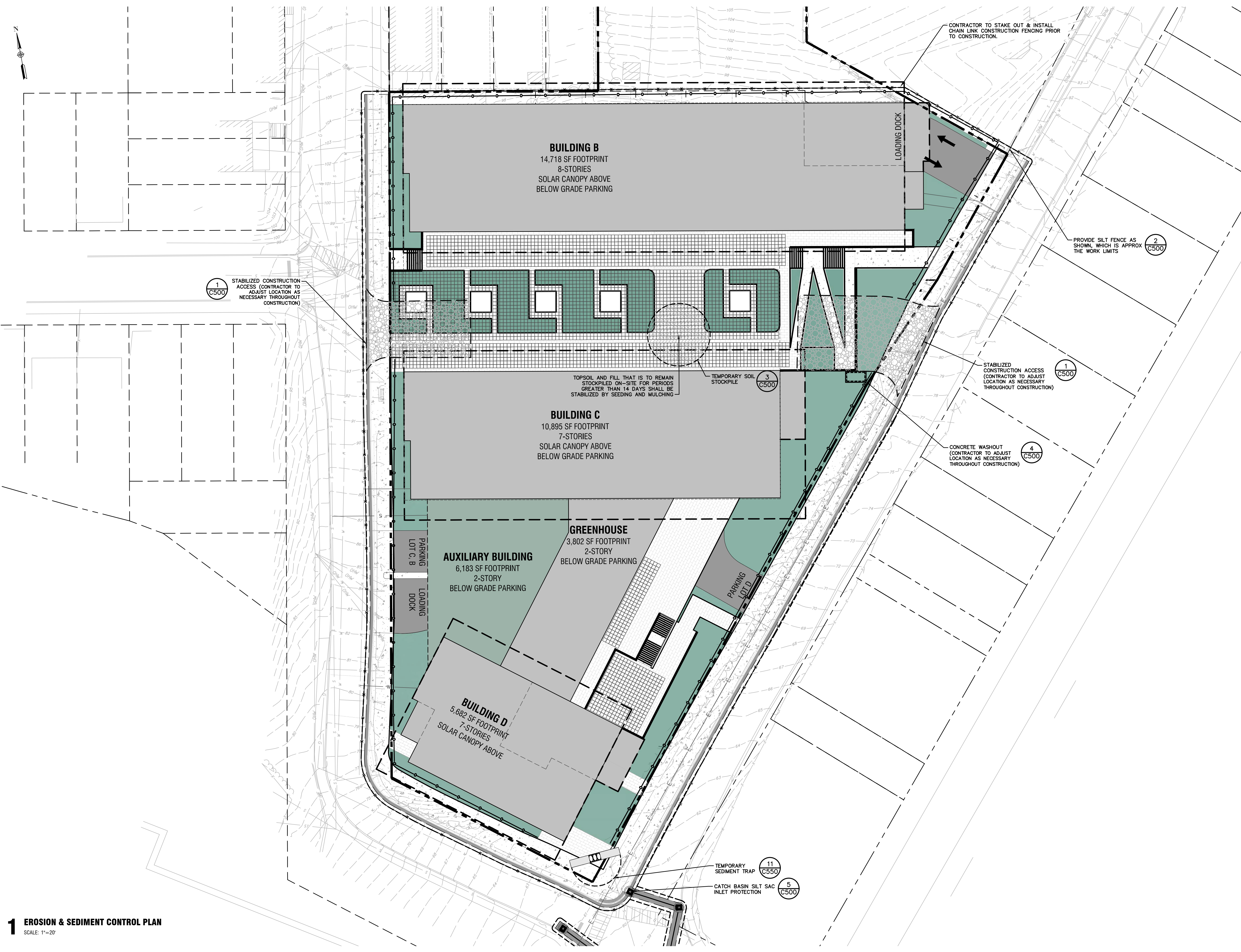

THE SEVENTY-SIX

Parcel 76, 76 Second Avenue, City of Albany, NY

Owner: South End Development LLC

Architect:
Garrison-Architects
45 Main Street
Brooklyn, NY 11201

Civil Engineer:
The Chazen Companies
547 River St.
Troy, NY 12180
p (518) 273-0055
Chazen Project No. 32019.00

Revision Schedule

Revision Number	Revision Description	Revision Date

Schematic Design

Scale: AS NOTED
Date: 06/23/2020
Project No: 2005
Drawn by: KC/SM
Checked by: RK

Seal & Signature:

DOB Stamp & Signature

DOB Scan:

Drawing Title:
Utility Plan

Drawing Number:

C-160

DWG.No:

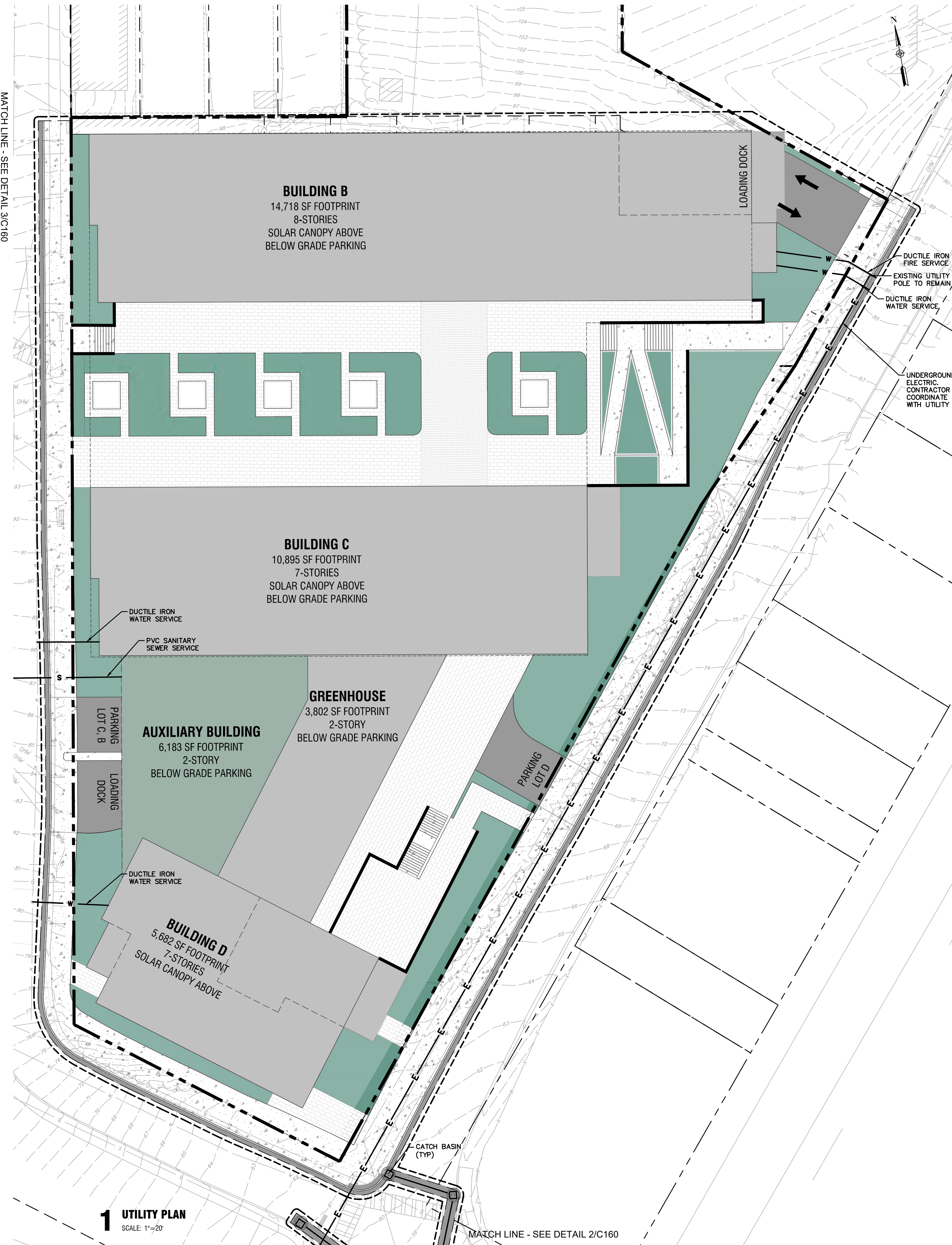
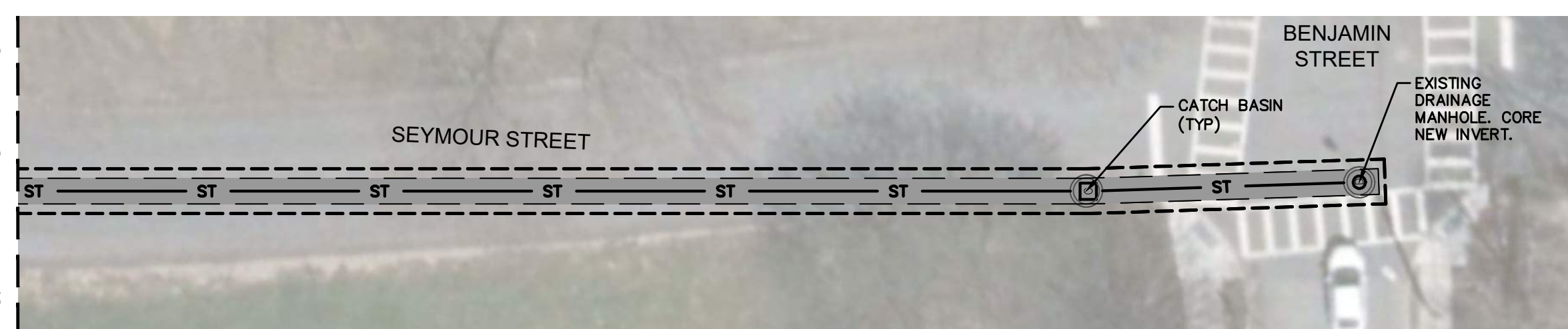
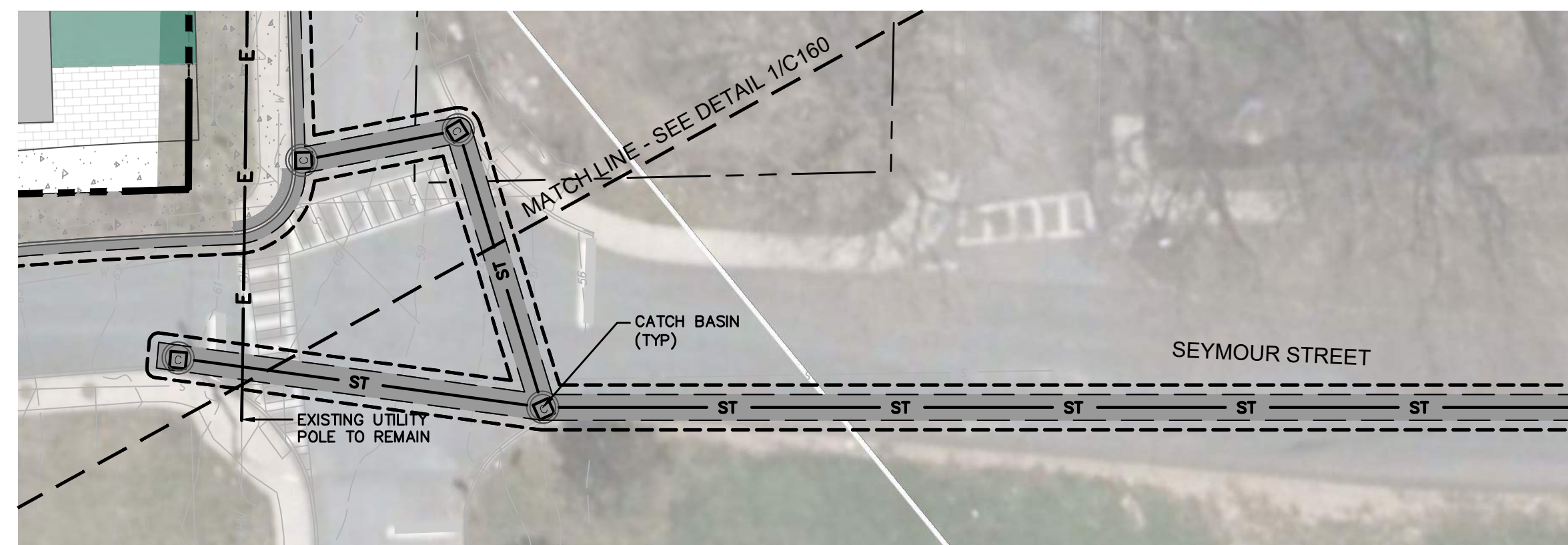

THE SEVENTY-SIX

Parcel 76, 76 Second Avenue, City of Albany, NY

Owner: South End Development LLC

Architect:
Garrison-Architects
45 Main Street
Brooklyn, NY 11201

Civil Engineer:
The Chazen Companies
547 River St.
Troy, NY 12180
p (518) 273-0055
Chazen Project No. 32019.00

Revision Schedule

Revision Number	Revision Description	Revision Date
-----------------	----------------------	---------------

Schematic Design

Scale: AS NOTED
Date: 06/23/2020
Project No: 2005
Drawn by: KC/SM
Checked by: RK

Seal & Signature:

DOB Stamp & Signature

DOB Scan:

Drawing Title:

Landscaping Plan

Drawing Number:

C-180

DWG.No:



THE SEVENTY-SIX

Parcel 76, 76 Second Avenue, City of Albany, NY

Owner: South End Development LLC

Architect:
Garrison-Architects
45 Main Street
Brooklyn, NY 11201

Civil Engineer:
The Chazen Companies
547 River St.
Troy, NY 12180
p (518) 273-0055
Chazen Project No. 32019.00

Revision Schedule

Revision Number	Revision Description	Revision Date

Schematic Design

Scale: AS NOTED
Date: 06/23/2020
Project No: 2005
Drawn by: KC/SM
Checked by: RK

Seal & Signature:

DOB Stamp & Signature

DOB Scan:

Drawing Title:
**Delivery Truck
Maneuvering Plan**

Drawing Number:

C-190

DWG.No:

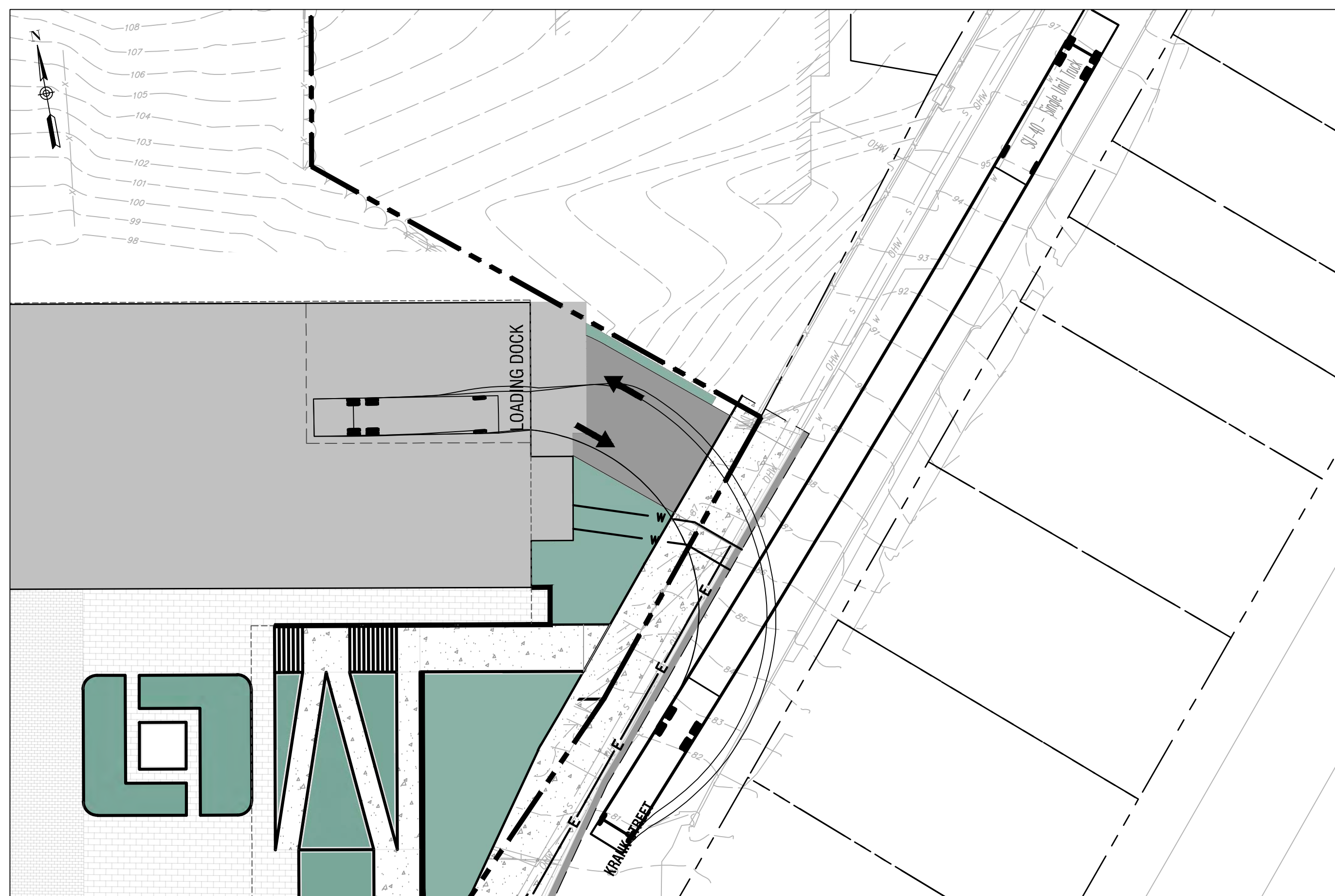

1 DELIVERY TRUCK BACK INTO LOADING DOCK AREA - KRANK STREET
SCALE: 1"=20'

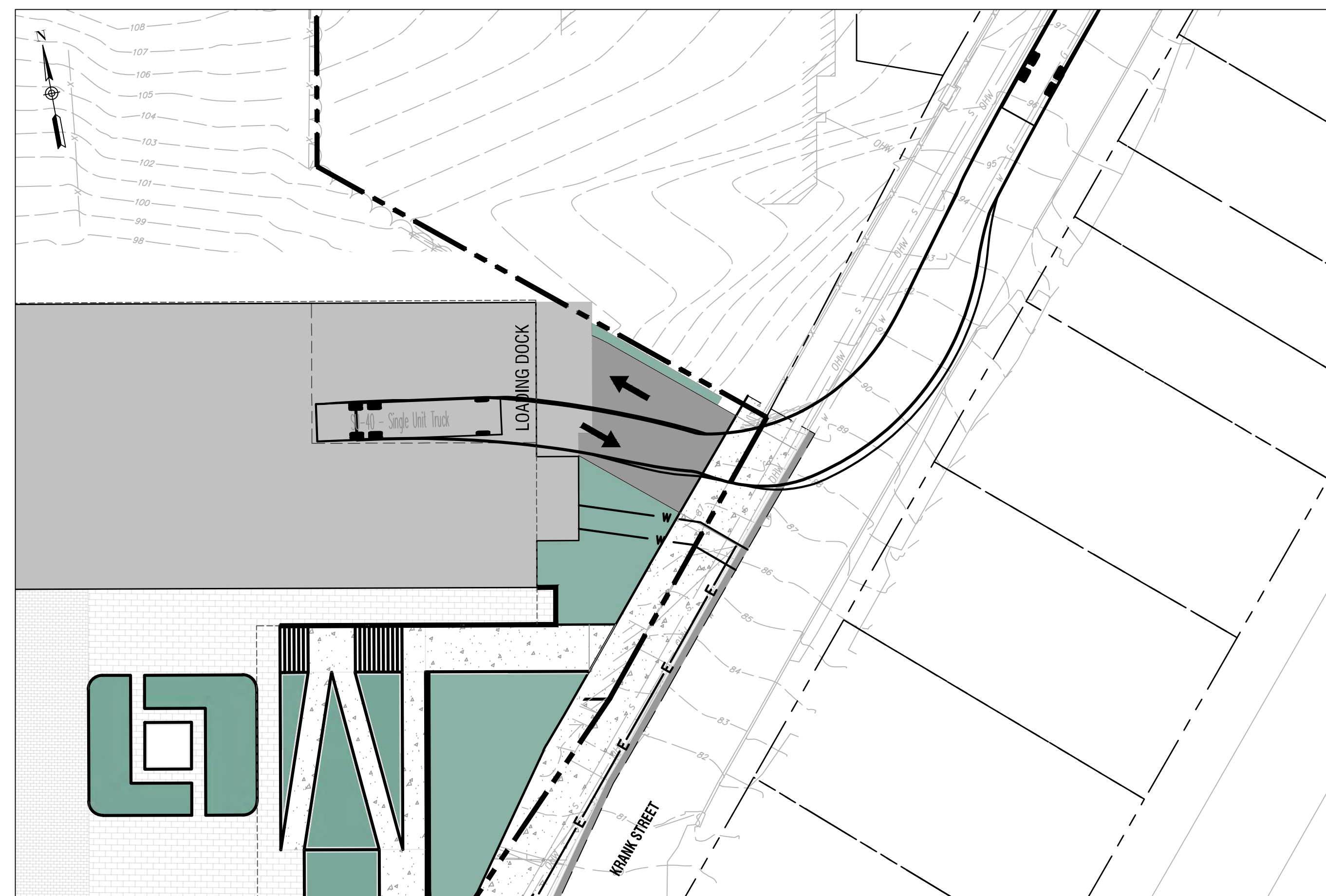

2 DELIVERY TRUCK LEAVING LOADING DOCK AREA - KRANK STREET
SCALE: 1"=20'

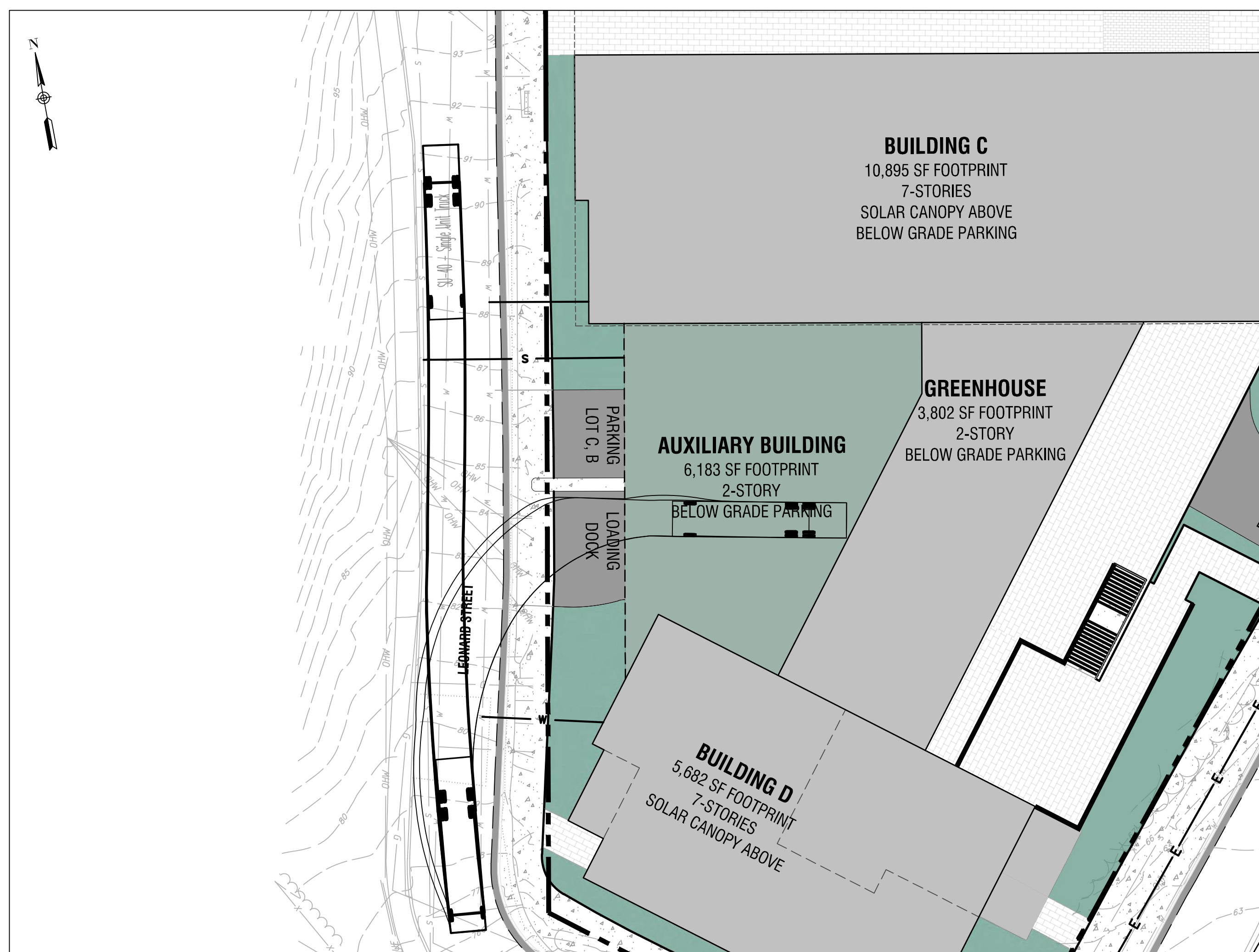

3 DELIVERY TRUCK BACK INTO LOADING DOCK AREA - LEONARD STREET
SCALE: 1"=20'

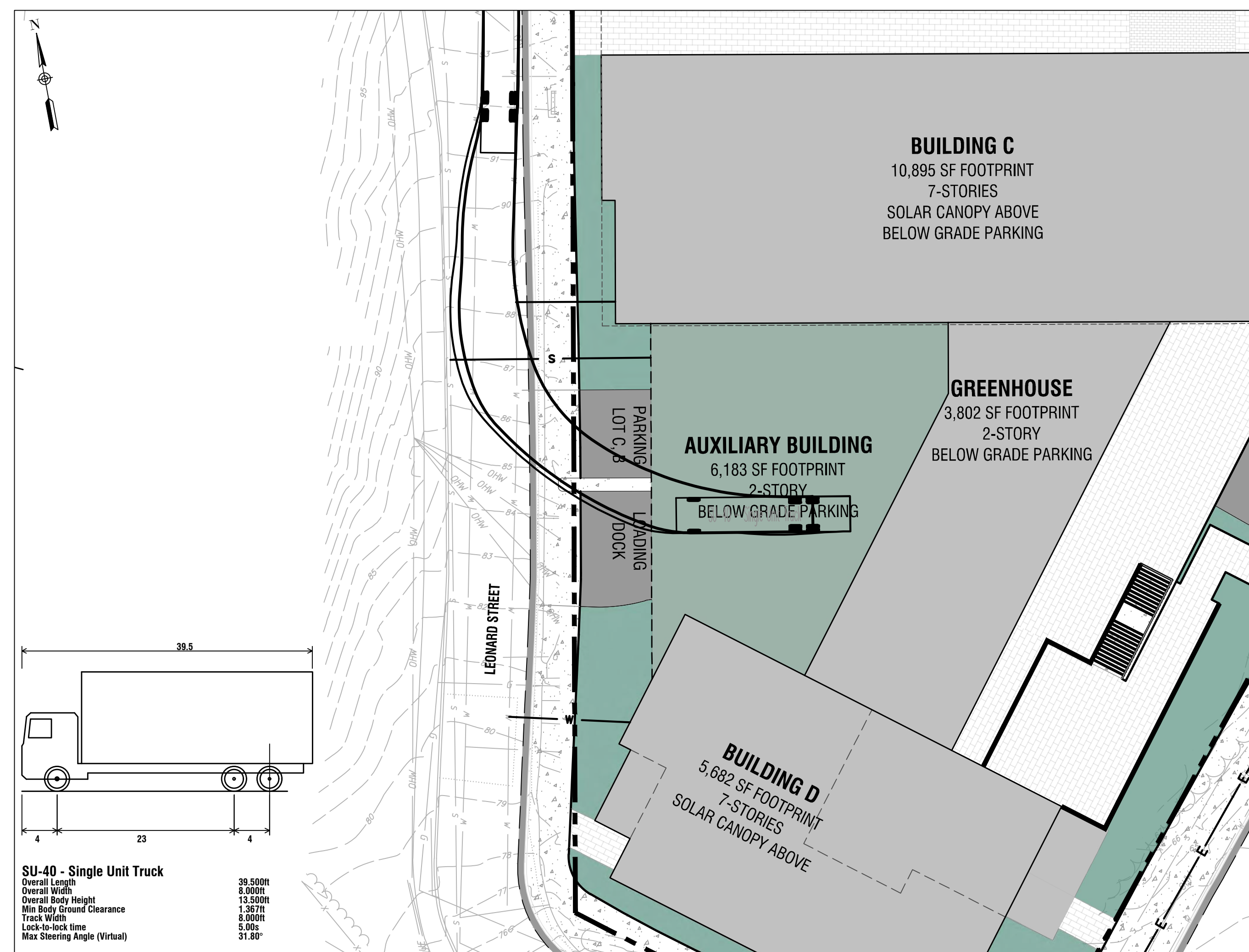

4 DELIVERY TRUCK LEAVING LOADING DOCK AREA - LEONARD STREET
SCALE: 1"=20'

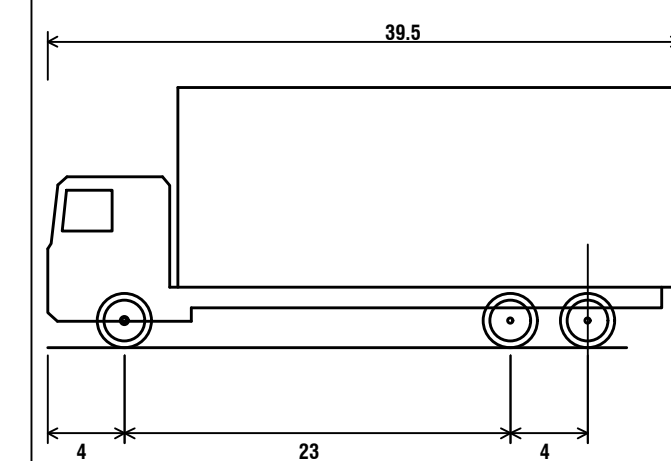

SU-40 - Single Unit Truck
Overall Length 39.500ft
Overall Width 8.000ft
Overall Body Height 13.500ft
Min Body Ground Clearance 1.267ft
Track Width 8.000ft
Lock-to-lock time 3.00s
Max Steering Angle (Virtual) 31.80°

THE SEVENTY-SIX

Parcel 76, 76 Second Avenue, City of Albany, NY

Owner: South End Development LLC

Architect:
Garrison-Architects
45 Main Street
Brooklyn, NY 11201

Civil Engineer:
The Chazen Companies
547 River St.
Troy, NY 12180
p (518) 273-0055
Chazen Project No. 32019.00

Revision Schedule

Revision Number	Revision Description	Revision Date

Schematic Design

Scale: AS NOTED
Date: 06/23/2020
Project No: 2005
Drawn by: KC/SM
Checked by: RK

Seal & Signature:

DOB Stamp & Signature

DOB Scan:

Drawing Title:
**Passenger Car
Maneuvering Plan**

Drawing Number:

C-191

DWG.No:

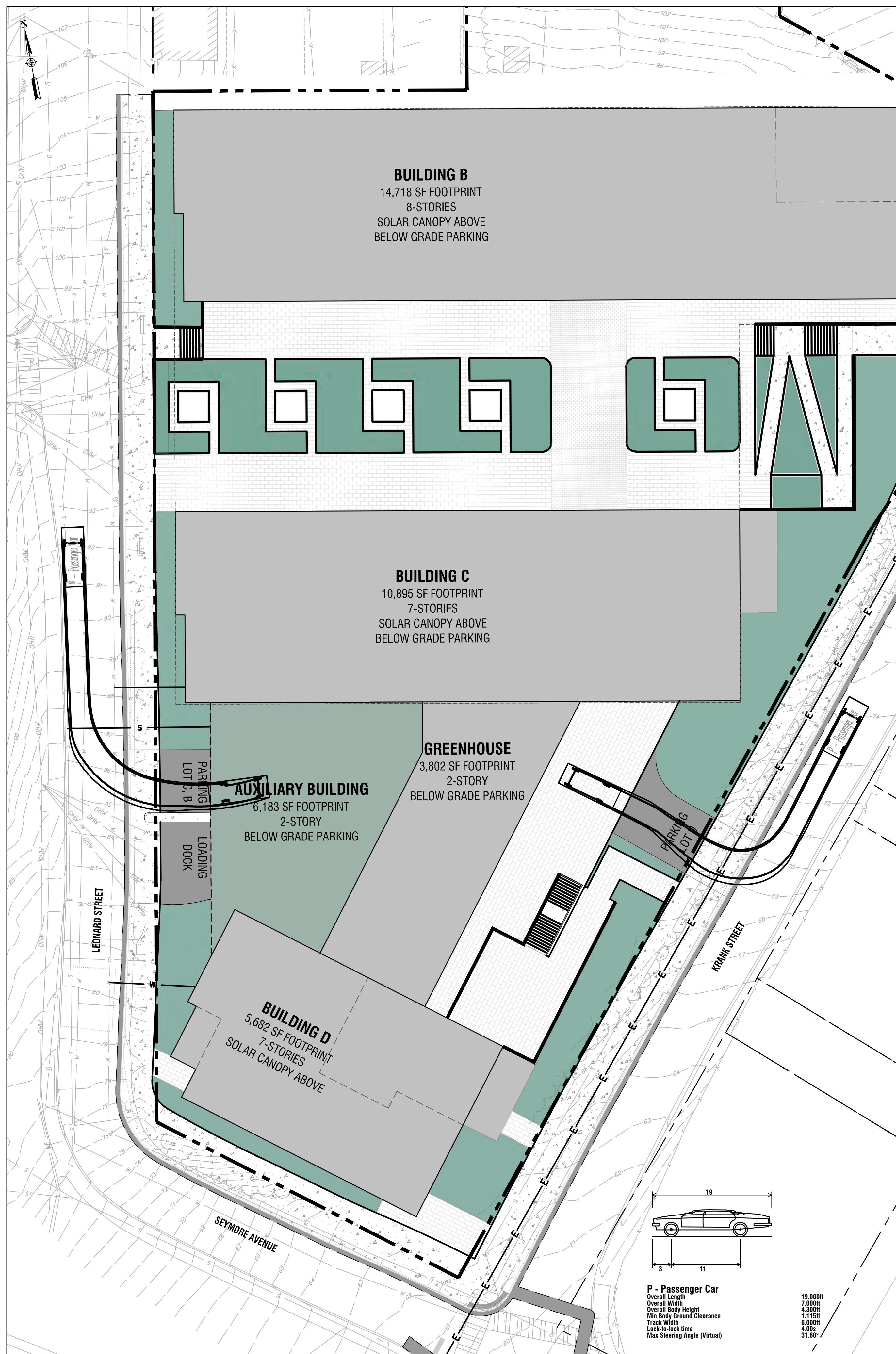

1 PASSENGER CAR ENTERING PARKING LOTS
SCALE: 1"=20'

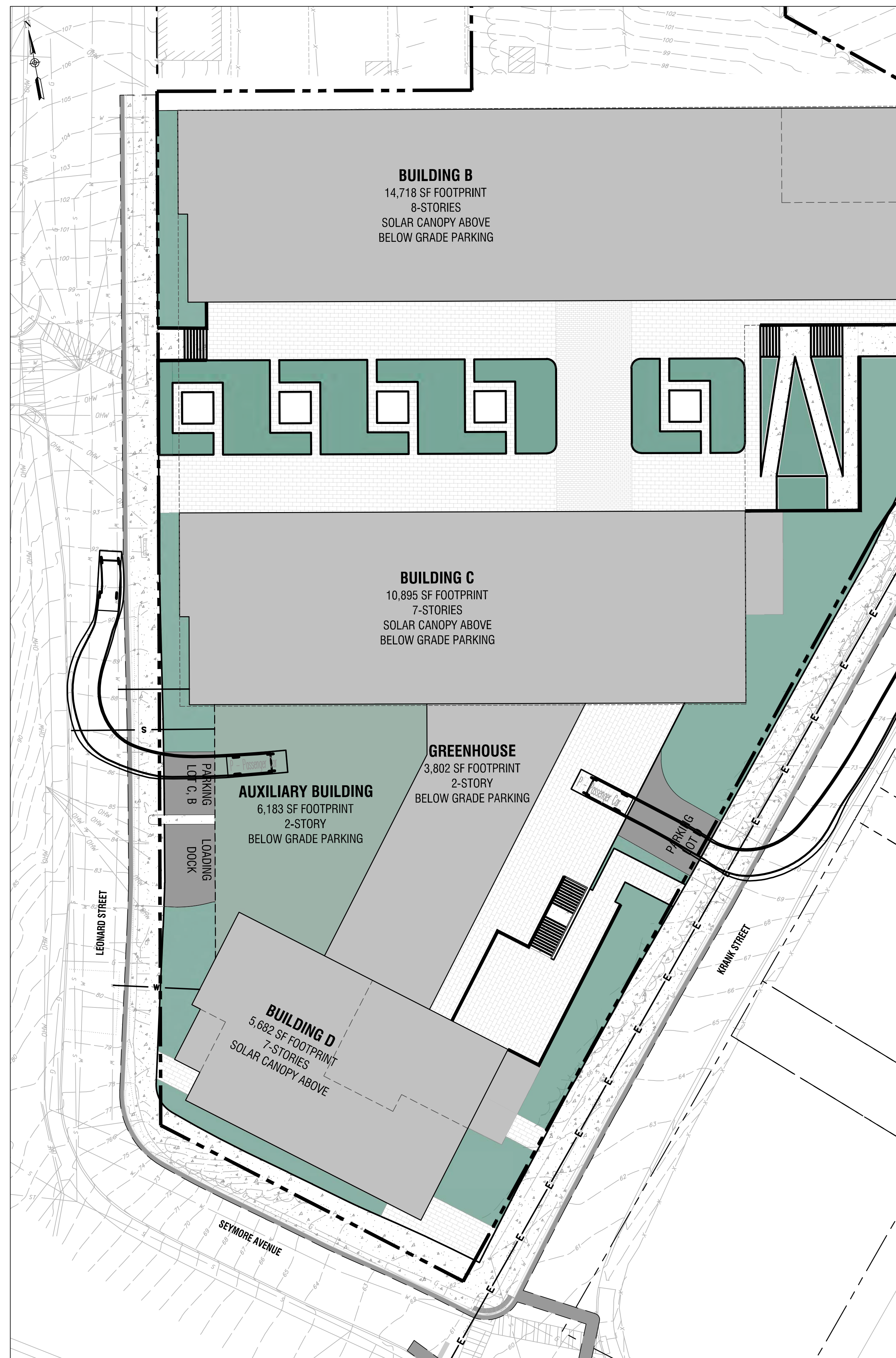

2 PASSENGER CAR EXITING PARKING LOTS
SCALE: 1"=20'

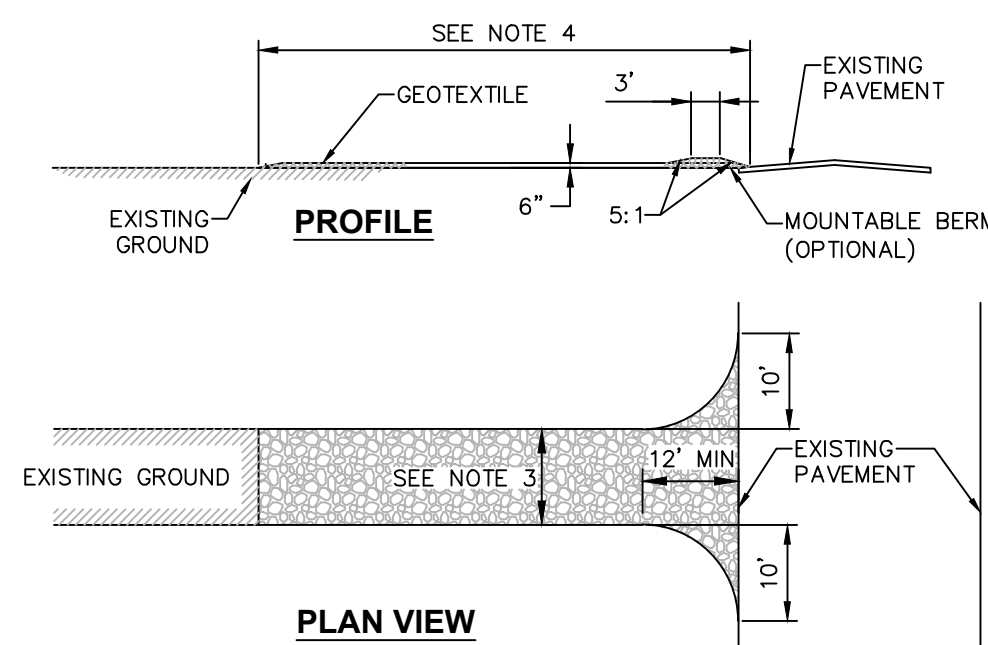

CONSTRUCTION ENTRANCE SPECIFICATIONS:

- STONE SIZE - USE 2" STONE, OR RECLAIMED OR RECYCLED CONCRETE EQUIVALENT.
- THICKNESS - NOT LESS THAN SIX (6) INCHES.
- WIDTH - TWELVE (12) FOOT MINIMUM, BUT NOT LESS THAN THE FULL WIDTH AT POINTS WHERE INGRESS OR EGRESS OCCURS. TWENTY FOUR (24) FEET IF SINGLE ENTRANCE TO SITE.
- LENGTH - NOT LESS THAN 50' (EXCEPT ON A SINGLE RESIDENCE LOT WHERE A 30' MINIMUM LENGTH WOULD APPLY).
- GEOTEXTILE - WILL BE PLACED OVER THE ENTIRE AREA PRIOR TO PLACING OF STONE.
- SURFACE WATER - ALL SURFACE WATER FLOWING OR DIVERTED TOWARD CONSTRUCTION ENTRANCES SHALL BE PIPED ACROSS THE ENTRANCE. IF PIPING IS IMPRACTICAL, A MOUNTABLE BERM WITH 5:1 SLOPES WILL BE PERMITTED.
- MAINTENANCE - THE ENTRANCE SHALL BE MAINTAINED IN A CONDITION WHICH WILL PREVENT TRACKING OR FLOWING OF SEDIMENT ONTO PUBLIC RIGHTS-OF-WAY. THIS MAY REQUIRE PERIODIC TOP DRESSING WITH ADDITIONAL STONE AS CONDITIONS DEMAND AND REPAIR AND/OR CLEANOUT OF ANY MEASURES USED TO TRAP SEDIMENT. ALL SEDIMENT SPILLED, DROPPED, WASHED OR TRACKED ONTO PUBLIC RIGHTS-OF-WAY MUST BE REMOVED IMMEDIATELY.
- WASHING - WHEELS SHALL BE CLEANED TO REMOVE SEDIMENT PRIOR TO ENTRANCE ONTO PUBLIC RIGHTS-OF-WAY. WHEN WASHING IS REQUIRED, IT SHALL BE DONE ON AN AREA STABILIZED WITH STONE AND WHICH DRAINS INTO AN APPROVED SEDIMENT TRAPPING DEVICE.
- PERIODIC INSPECTION AND NEEDED MAINTENANCE SHALL BE PROVIDED AFTER EACH RAIN.

1 STABILIZED CONSTRUCTION ACCESS DETAIL
SCALE: NOT TO SCALE

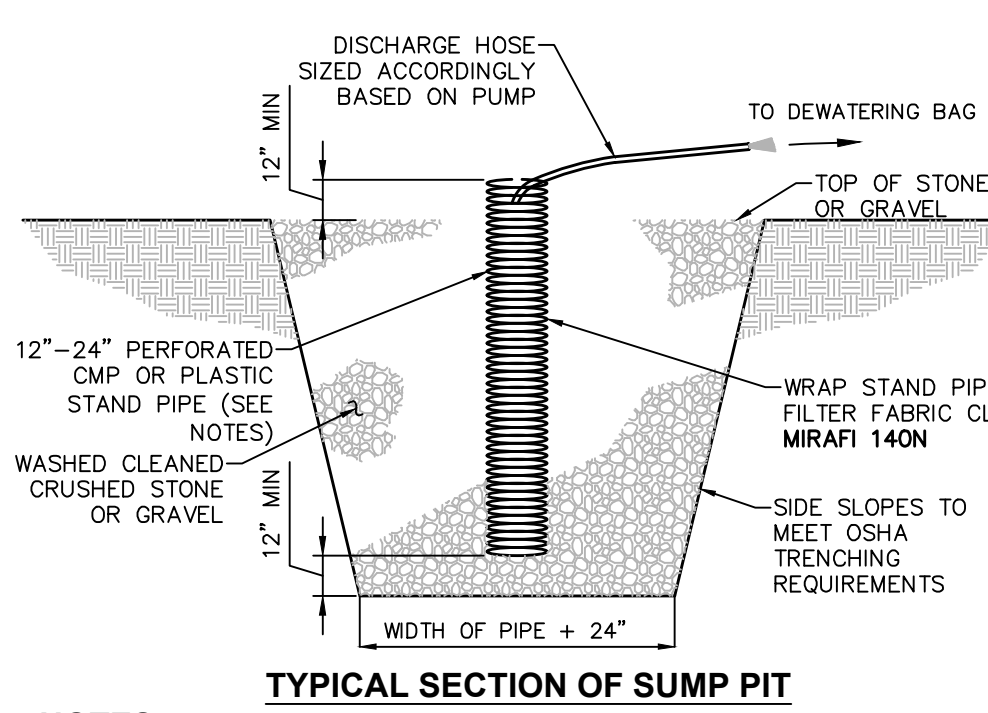

TYPICAL SECTION OF SUMP PIT

NOTES:

- SUMP PIT QUANTITY & LOCATION SHALL BE DETERMINED BY CONTRACTOR.
- PERFORATIONS IN THE STANDPIPE SHALL BE EITHER CIRCULAR OR SLOTS. PERFORATION SIZE SHALL NOT EXCEED 1/2" INCH DIAMETER. PUMP RATE SHALL NOT EXCEED INFLOW RATE INTO STAND PIPE.
- CRUSHED STONE OR GRAVEL SHALL BE NYSDOT #2 SIZE OR EQUIVALENT AND SHALL BE WASHED PRIOR TO PLACEMENT WITHIN SUMP.
- DISCHARGE SHALL BE THROUGH DEWATERING BAGS, OR AS DIRECTED BY ENGINEER.
- CONTRACTOR TO SUBMIT DEWATERING PLAN TO ENGINEER FOR REVIEW & APPROVAL.

7 DEWATERING & SUMP PIT DETAIL
SCALE: NOT TO SCALE

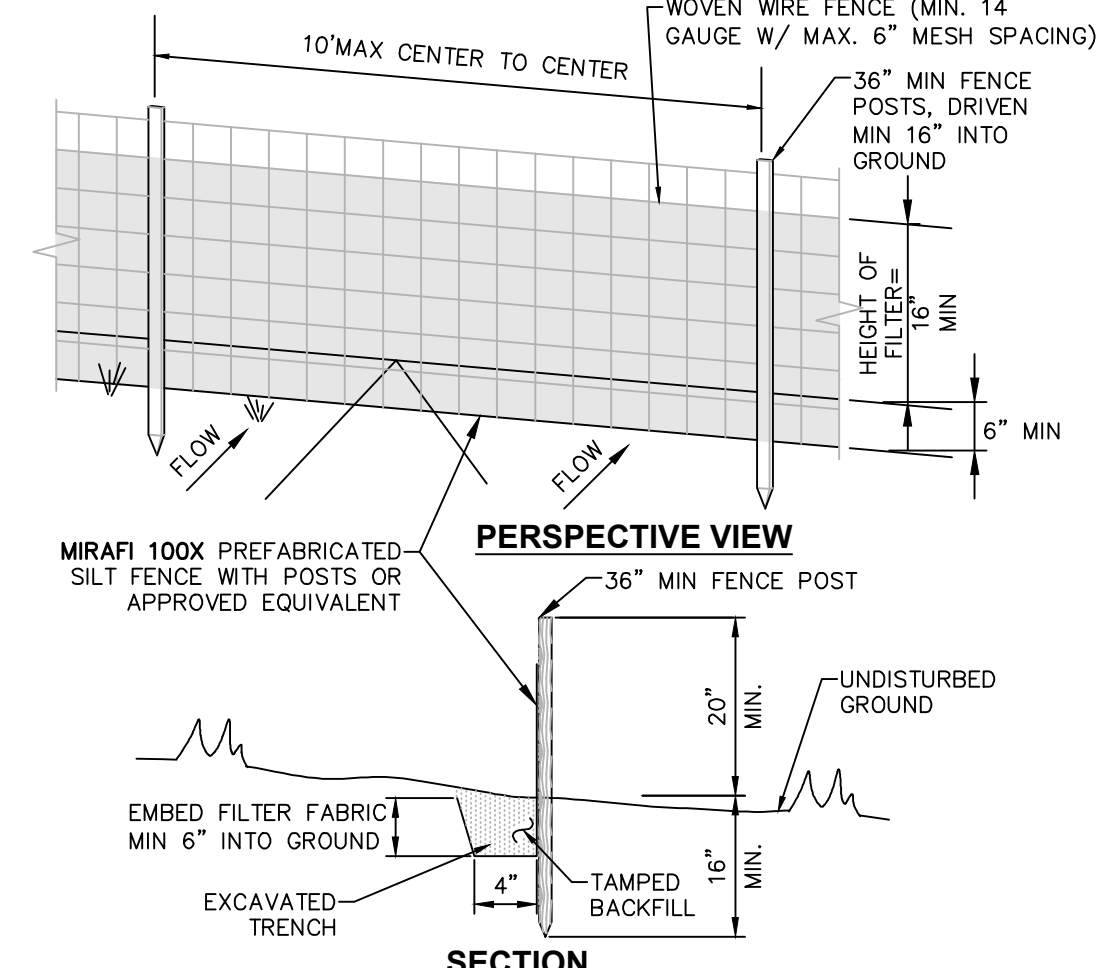

NOTES:

- AREA CHOSEN FOR STOCKPILING OPERATIONS SHALL BE DRY AND STABLE.
- MAXIMUM SLOPE OF STOCKPILE SHALL BE 1V:2H.
- UPON COMPLETION OF SOIL STOCKPILING, EACH PILE SHALL BE SURROUNDED WITH SILT FENCING, THEN STABILIZED WITH VEGETATION OR COVERED.
- SEE SPECIFICATIONS FOR INSTALLATION OF SILT FENCE.

2 SILT FENCE INSTALLATION DETAIL
SCALE: NOT TO SCALE

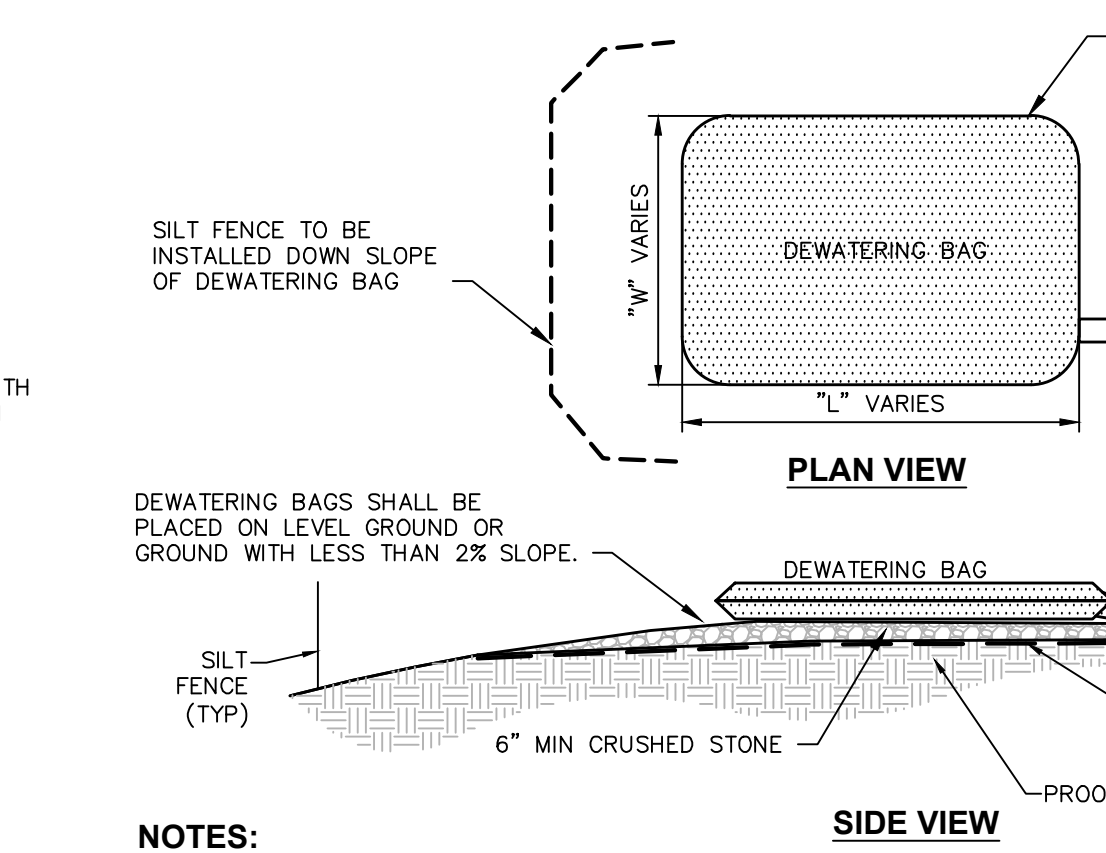

NOTES:

- SEDIMENT COLLECTION BAG SHALL BE EQUAL TO DIRTBAG® 55, AS MARKETING BY ACF ENVIRONMENTAL, RICHMOND, VIRGINIA (800-448-3636), OR APPROVED EQUIVALENT.
- SEDIMENT COLLECTION BAG SHALL BE A NONWOVEN BAG SEWN WITH HIGH STRENGTH THREAD. THE SEAMS SHALL BE HIGH STRENGTH, DOUBLE STITCHED, "J" TYPE SEAMS.
- BAGS SHALL HAVE SEWN IN FILL SPOUT LARGE ENOUGH TO ACCOMMODATE UP TO A 4" DISCHARGE HOSE. FILL SPOUT SHALL HAVE HIGH STRENGTH STRAPPING TO HOLD HOSE IN PLACE AND PREVENT PUMPED WATER FROM ESCAPING WITHOUT BEING FILTERED.
- SEDIMENT COLLECTION BAGS SHALL BE INSTALLED IN ACCORDANCE WITH THE MANUFACTURER'S INSTRUCTIONS, OR AS DIRECTED BY THE ENGINEER.
- SEDIMENT COLLECTED SHALL BE DISPOSED OF AT AN APPROPRIATE FACILITY.
- SEDIMENT COLLECTION BAGS SHALL BE REMOVED AND REPLACED UNDER ANY OF THE FOLLOWING CONDITIONS:
 - WHEN BAGS ARE FULL.
 - WHEN BAGS HAVE BEEN IN PLACE FOR MORE THAN 30 DAYS (REMOVAL REQUIRED DUE TO ULTRAVIOLET DETERIORATION).
 - WHEN BAGS ARE DAMAGED.
- ALL SEDIMENT COLLECTION BAGS SHALL BE INSPECTED DAILY BY THE CONTRACTOR.
- CARE SHALL BE TAKEN DURING REMOVAL TO MINIMIZE LOSS OF ENTRAPPED SEDIMENT.

8 SEDIMENT COLLECTION DEWATERING BAG DETAIL
SCALE: NOT TO SCALE

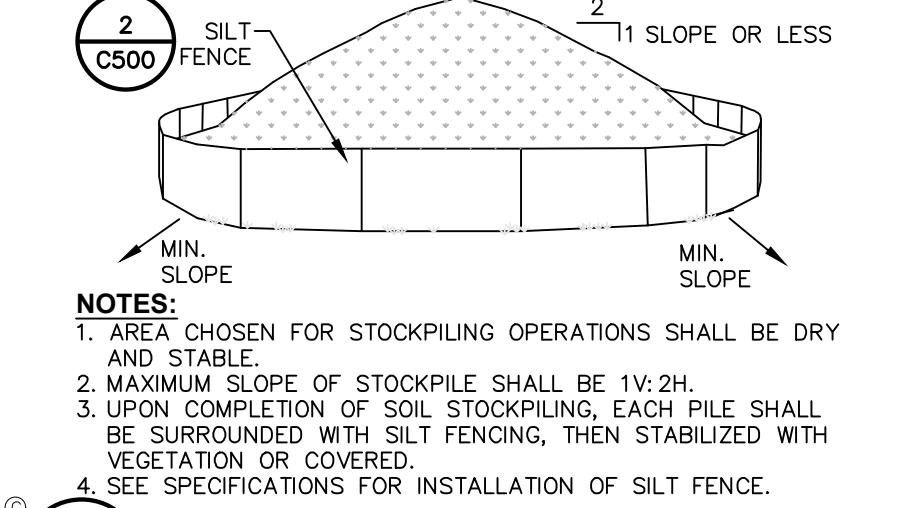

3 TEMPORARY SOIL STOCKPILE DETAIL
SCALE: NOT TO SCALE

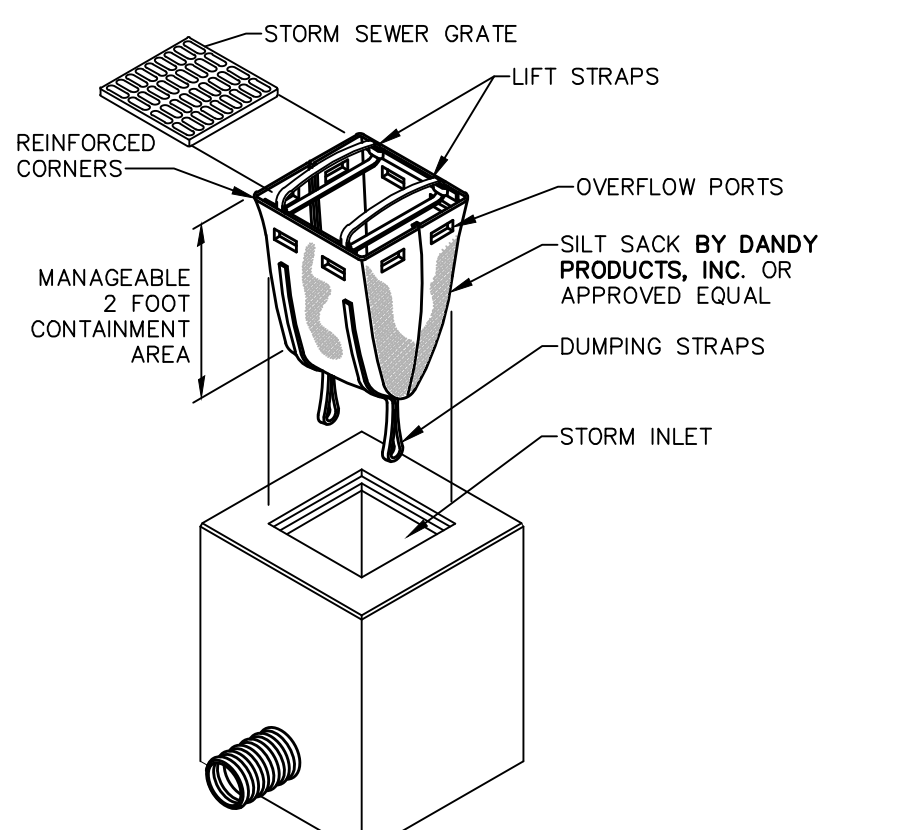

5 SILT SACK DETAIL
SCALE: NOT TO SCALE

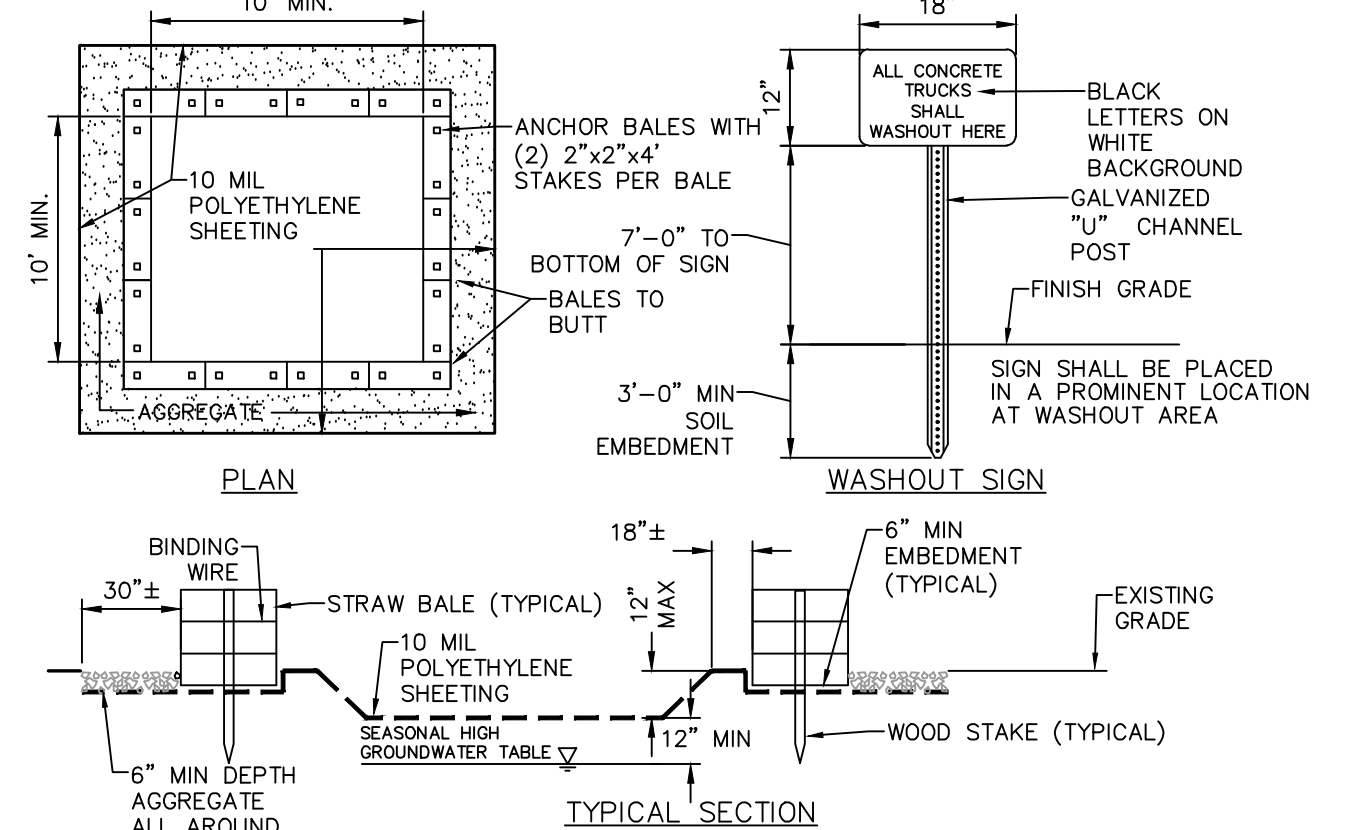

NOTES:

- CONTAINMENT MUST BE STRUCTURALLY SOUND AND LEAK FREE AND CONTAIN ALL LIQUID WASTES.
- CONTAINMENT DEVICES MUST BE OF SUFFICIENT QUANTITY OR VOLUME TO COMPLETELY CONTAIN THE LIQUID WASTES GENERATED.
- WASHOUT MUST BE CLEANED OR NEW FACILITIES CONSTRUCTED AND READY TO USE ONCE WASHOUT IS 75% FULL. THIS INCLUDES REPLACEMENT OF THE 10 MIL POLYETHYLENE SHEETING.
- WASHOUT AREA(S) SHALL BE INSTALLED IN A LOCATION EASILY ACCESSIBLE BY CONCRETE TRUCKS.
- ONE OR MORE AREAS MAY BE INSTALLED ON THE CONSTRUCTION SITE AND MAY BE RELOCATED AS CONSTRUCTION PROGRESSES.
- AT LEAST WEEKLY, REMOVE ACCUMULATION OF SAND AND AGGREGATE AND DISPOSE OF PROPERLY.

4 CONCRETE WASHOUT AREA DETAIL
SCALE: NOT TO SCALE

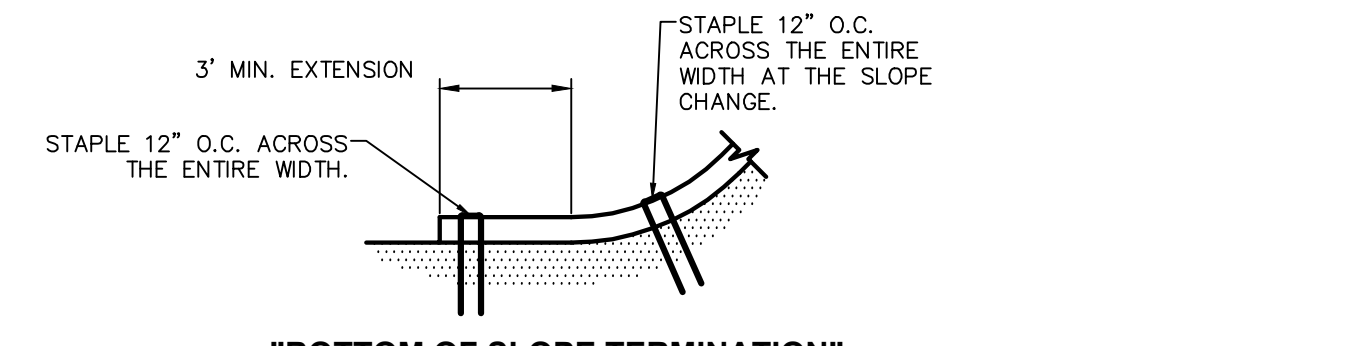

"BOTTOM OF SLOPE TERMINATION"

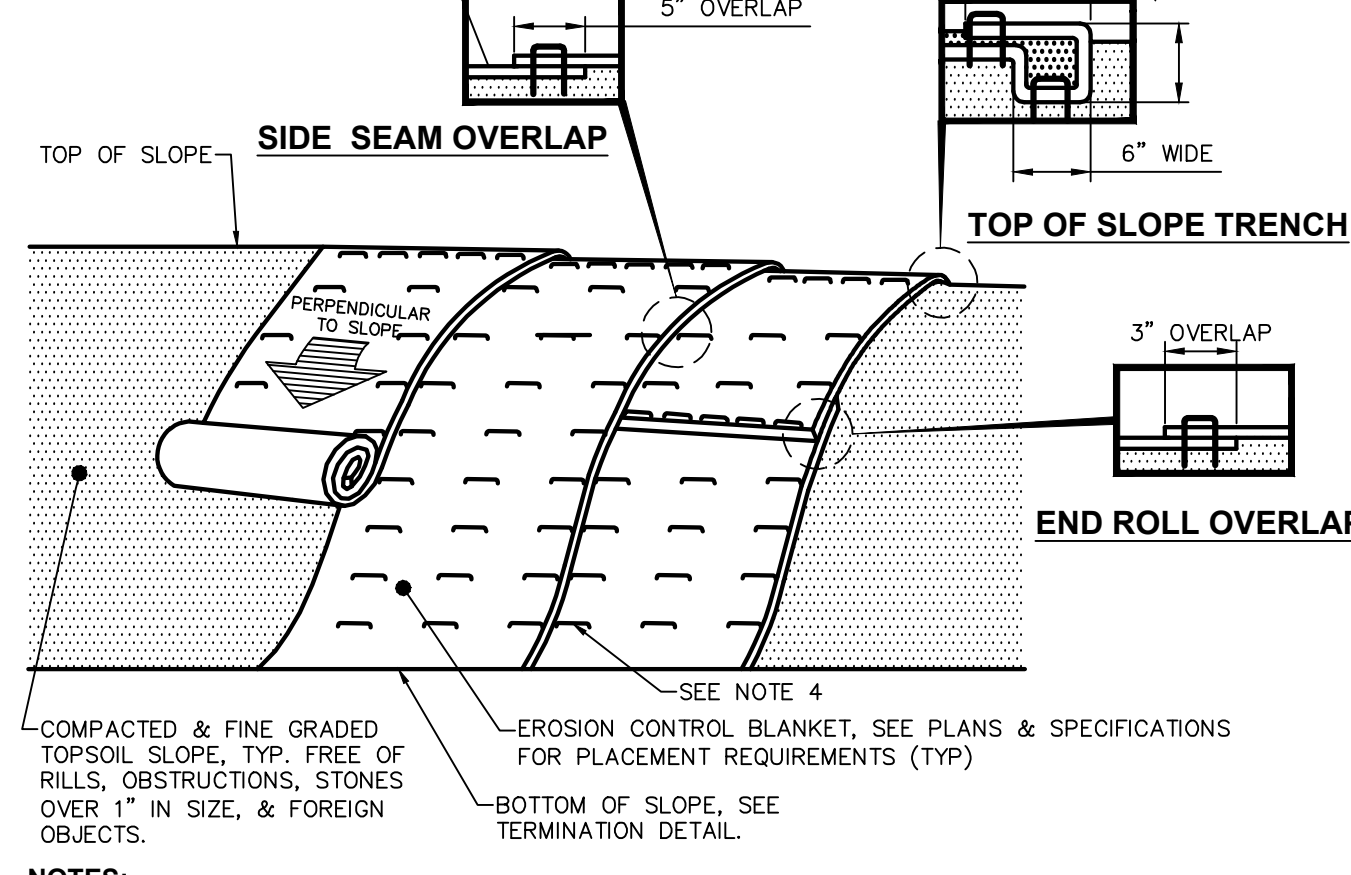

NOTES:

- PREPARE THE TOPSOIL (SEEDBED) FIRST BY RAKING, SHAPING, FINE GRADING, COMPACTING, SEEDING & FERTILIZING THE SLOPES.
- USE THE TRENCHING & ANCHORING PROCEDURES DETAILED HEREIN TO SECURE ANY EXPOSED MATERIAL ENDS. SECURE ALL PRODUCT OVERLAPS. OVERLAP IN THE DIRECTION OF WATER FLOW, PERPENDICULAR TO THE SLOPE.
- KEEP EROSION CONTROL BLANKET IN SOLID CONTACT WITH THE TOPSOIL.
- USE THE REQUIRED NUMBER OF STAPLES/STAKES TO SECURELY FASTEN THE EROSION CONTROL BLANKET TO THE SLOPE. IN LOOSE SOIL CONDITIONS, THE USE OF STAPLES/STAKES LENGTHS GREATER THAN 6" MAYBE NECESSARY FOR PROPER SECURING. STAPLE PATTERNS & OVERLAPS ARE DEPENDENT ON SITE CONDITIONS & MANUFACTURER'S REQUIREMENTS. CONTRACTOR SHALL CONSULT WITH MANUFACTURER FOR ACTUAL SITE SPECIFIC REQUIREMENTS.

TRENCHING & ANCHORING PROCEDURE NOTES:

SIDE SEAM OVERLAP: THE EDGES OF PARALLEL BLANKETS SHALL BE STAPLED WITH A 5" OVERLAP.

TOP OF SLOPE TRENCH: BEGIN AT THE TOP OF SLOPE BY ANCHORING THE EROSION CONTROL BLANKET IN A 6" D x 6" W TRENCH WITH A 12" OVERLAP EXTENDED BEYOND THE UP-SLOPE PORTION OF THE TRENCH. ANCHOR WITH A ROW OF STAPLES/STAKES 12" O.C. IN THE BOTTOM OF THE TRENCH. BACKFILL & COMPACT THE TRENCH AFTER STAPLING. APPLY SEED TO THE COMPACTED SOIL & FOLD THE REMAINING 12" PORTION OF THE EROSION CONTROL BLANKET BACK OVER THE SEED & COMPACTED SOIL. SECURE THE EROSION CONTROL BLANKET OVER THE COMPACTED SOIL WITH A ROW OF STAPLES/STAKES SPACED 12" O.C. ACROSS THE ENTIRE WIDTH.

END ROLL OVERLAP: CONSECUTIVE BLANKETS SPICED DOWN THE SLOPE SHALL BE PLACED END OVER END (SHINGLE-STYLE) WITH A 3" OVERLAP. STAPLE THRU OVERLAPPED AREAS, 12" APART ACROSS THE ENTIRE WIDTH.

9 EROSION CONTROL BLANKET INSTALLATION DETAIL
SCALE: NTS

THE SEVENTY-SIX

Parcel 76, 76 Second Avenue, City of Albany, NY

Owner: South End Development LLC

Architect: Garrison-Architects
45 Main Street
Brooklyn, NY 11201

Civil Engineer: The Chazen Companies
547 River St.
Troy, NY 12180
p (518) 273-0055
Chazen Project No. 32019.00

Revision Schedule		
Revision Number	Revision Description	Revision Date

Schematic Design

Scale: AS NOTED
Date: 06/23/2020
Project No: 2005
Drawn by: KC/SM
Checked by: RK

Seal & Signature:

DOB Stamp & Signature

DOB Scan:

Drawing Title:
Erosion & Sediment Control Details

Drawing Number:
C-500

DWG.No:

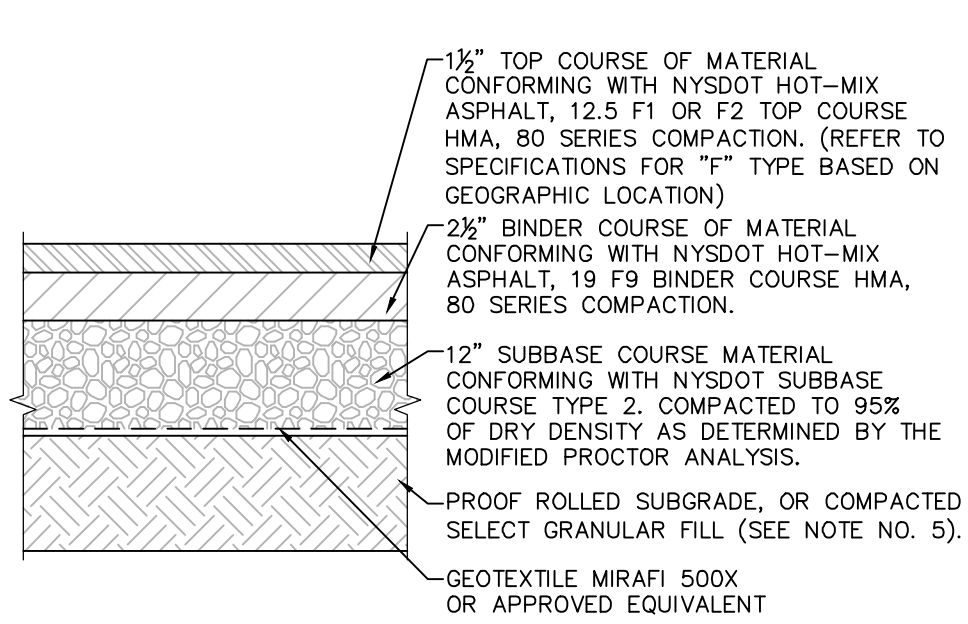

NOTES:
 1. MATERIALS AND METHODS OF CONSTRUCTION SHALL BE IN CONFORMANCE WITH THE NEW YORK STATE DEPARTMENT OF TRANSPORTATION (NYSDOT) STANDARD SPECIFICATIONS FOR CONSTRUCTION AND MATERIALS, DATED "CURRENT VERSION", AND ALL ADDENDA THERE TO.
 2. SUBBASE MATERIAL SHALL CONFORM WITH SECTION 304 - SUBBASE COURSE OF THE ABOVE REFERENCED NYSDOT STANDARD SPECIFICATIONS AND THE TYPE CALLED OUT IN THESE DRAWINGS.
 3. HOT MIX ASPHALT (HMA) PAVEMENT SHALL CONFORM WITH SECTION 400-HOT MIX ASPHALT OF THE ABOVE REFERENCED NYSDOT STANDARD SPECIFICATIONS AND THE TYPE CALLED OUT IN THESE DRAWINGS. ALTHOUGH SECTION 400 IN ITS ENTIRETY IS REFERENCED, THE HOT MIX ASPHALT (HMA) PAVEMENT(S) SPECIFIED FOR THIS CONTRACT SHALL BE AS SPECIFIED UNDER SECTION 402-HOT MIX ASPHALT (HMA) PAVEMENTS.
 4. TACK COAT WHEN SPECIFIED OR CALLED OUT IN THESE DRAWINGS OR REQUIRED BY THE REFERENCED SPECIFICATIONS SHALL CONFORM WITH SECTION 407-TACK COAT OF THE ABOVE REFERENCED NYSDOT STANDARD SPECIFICATIONS.
 5. WHERE IT IS NECESSARY TO PLACE FILL FOR PURPOSES OF BRINGING THE SUBGRADE ELEVATION UP TO A SPECIFIED GRADE, THE FILL MATERIAL PLACED SHALL BE IN CONFORMANCE WITH SECTION 203-EXCAVATION AND EMBANKMENT OF THE ABOVE REFERENCED NYSDOT STANDARD SPECIFICATIONS.
 6. PAVEMENT SECTION DESIGN IS BASED ON THE GEOTECHNICAL REPORT PREPARED BY THE CHAZEN COMPANIES DATED JULY 2020.

1 PAVEMENT SECTION DETAIL
 SCALE: NOT TO SCALE

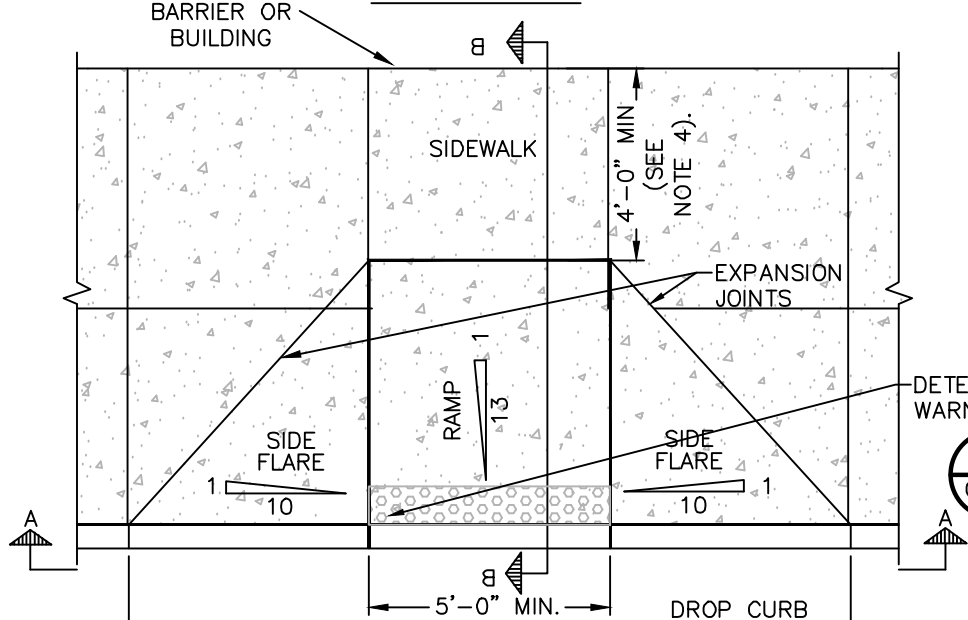
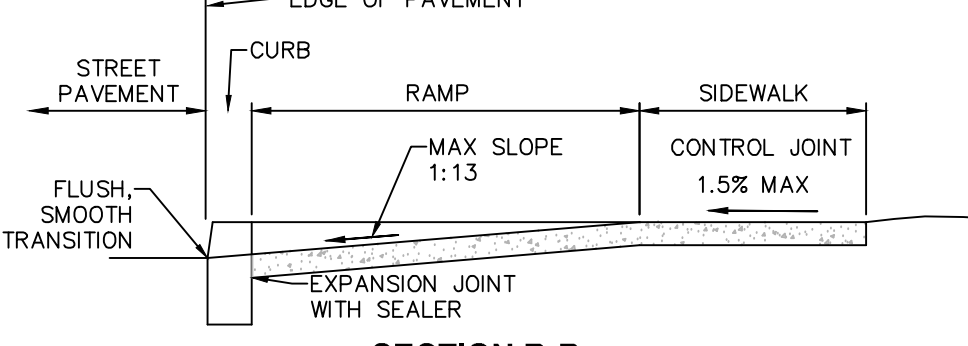
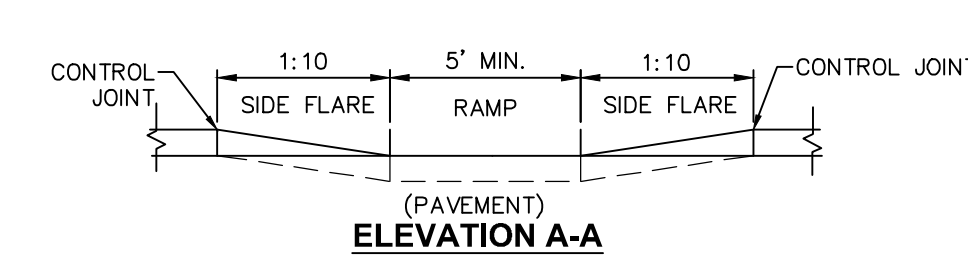

NOTES:
 1. ALL WORK SHALL CONFORM WITH THE NYSDOT STANDARD SPECIFICATION FOR CONSTRUCTION AND MATERIALS DATED, "CURRENT VERSION", AND ALL ADDENDA THERE TO; SPECIFICALLY SECTION 608- SIDEWALKS, DRIVEWAYS, AND BICYCLE PATHS.
 2. SLOPE RAMP AND SIDE FLARES AS INDICATED IN THE PLANS OR AS ORDERED BY THE ENGINEER.
 3. DETECTABLE WARNING UNITS SHALL BE PROVIDED ON ALL RAMPS IN ACCORDANCE W/ ADA REQUIREMENTS.
 4. WHERE THIS DIMENSION IS LESS THAN 4'-0", THE SIDE FLARES SHALL HAVE A SLOPE OF 1:13 OR FLATTER.

7 PEDESTRIAN RAMP WITH FLARED SLOPES
 SCALE: NOT TO SCALE

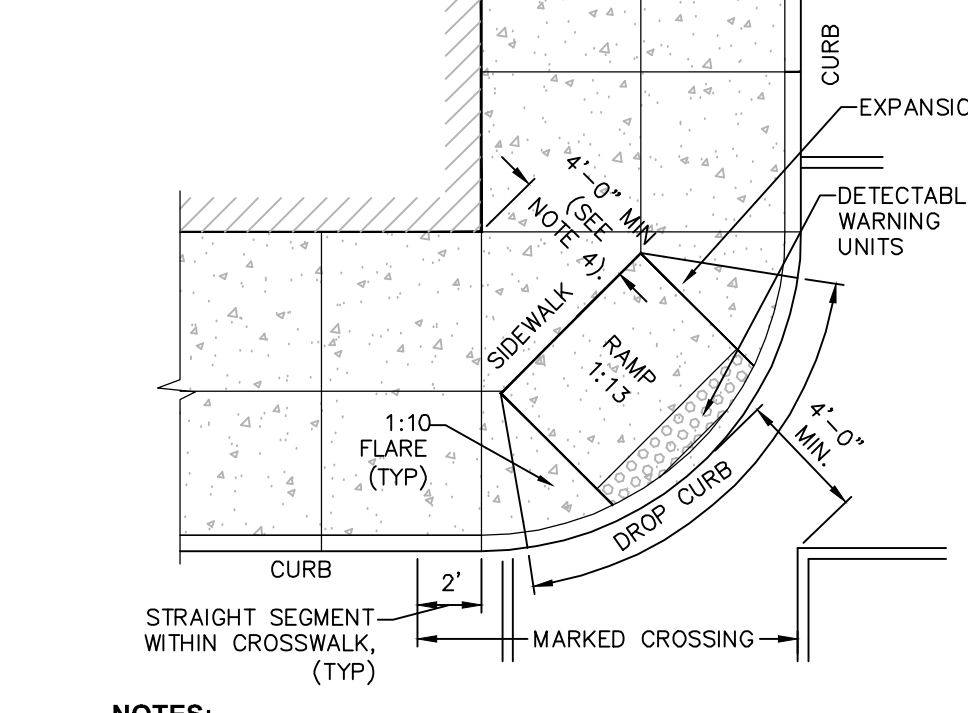

NOTES:
 1. ALL WORK SHALL CONFORM WITH THE NYSDOT STANDARD SPECIFICATION FOR CONSTRUCTION AND MATERIALS DATED, "CURRENT VERSION", AND ALL ADDENDA THERE TO; SPECIFICALLY SECTION 608- SIDEWALKS, DRIVEWAYS, AND BICYCLE PATHS.
 2. SLOPE RAMP AND SIDE FLARES AS INDICATED IN THE PLANS OR AS ORDERED BY THE ENGINEER.
 3. DETECTABLE WARNING UNITS SHALL BE PROVIDED ON ALL RAMPS IN ACCORDANCE W/ ADA REQUIREMENTS.
 4. WHERE THIS DIMENSION IS LESS THAN 4'-0", THE SIDE FLARES SHALL HAVE A SLOPE OF 1:13 OR FLATTER.

9 DIAGONAL PEDESTRIAN RAMP WITH FLARED SLOPES
 SCALE: NOT TO SCALE

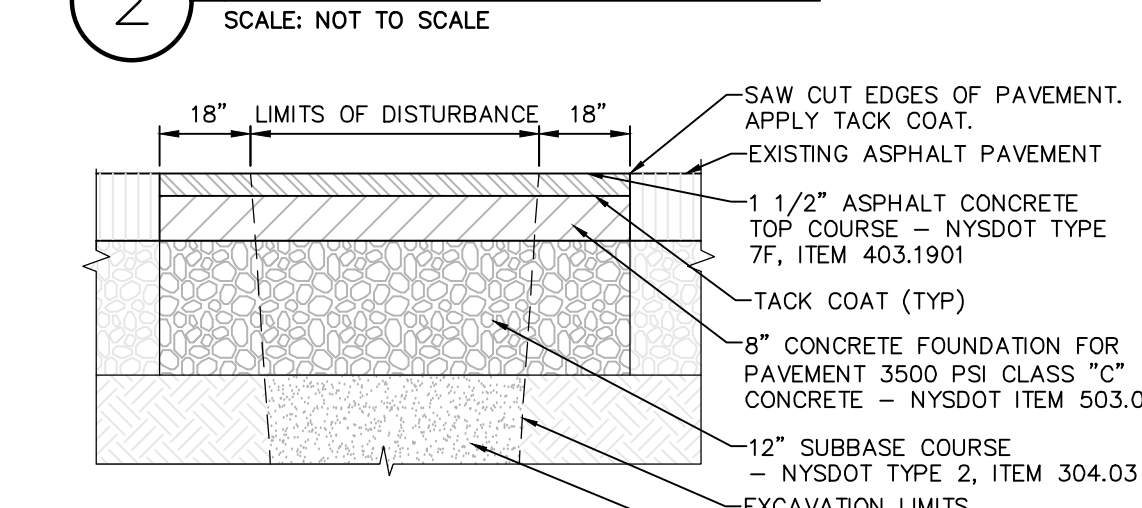
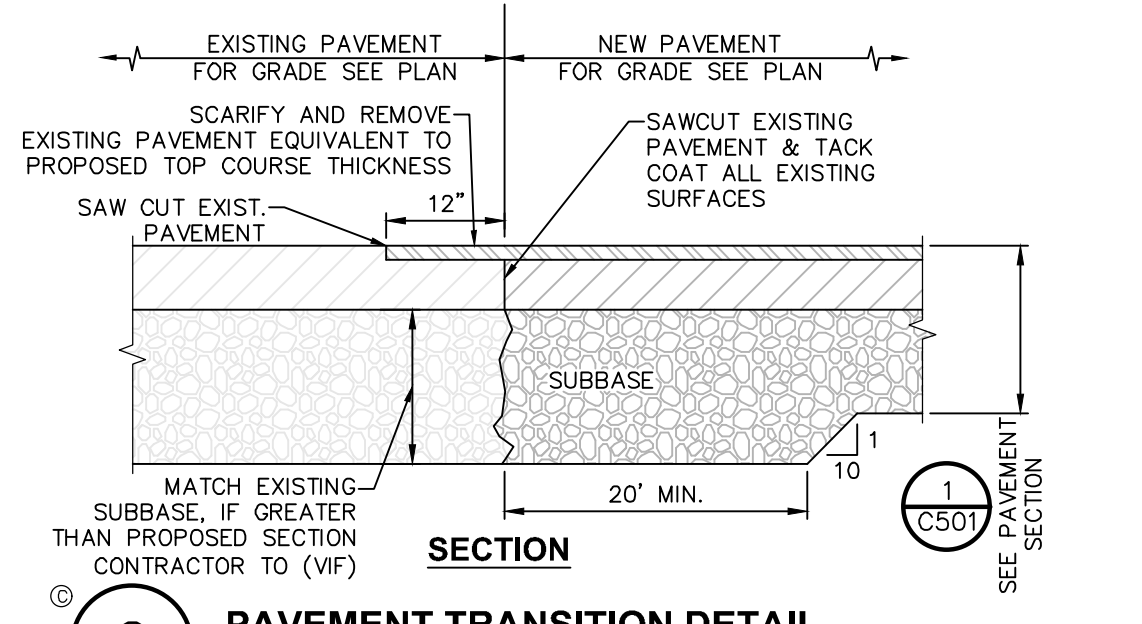

NOTES:
 1. IF LIMITS OF TRENCHING EXCEEDS 50 FEET, CONTRACTOR SHALL COMPLETE CURB TO CURB MILLING PER CITY DETAILS.
 2. ALL PAVEMENT MARKINGS DISTURBED SHALL BE RESTORED TO THE SATISFACTION OF THE CITY.
 3. ALL JOINTS TO BE SEALED WITH ASPHALT EMULSION (AC-20) NYSDOT ITEM 702-0500.

3 STREET RESTORATION ASPHALT PAVEMENT DETAIL
 SCALE: NOT TO SCALE

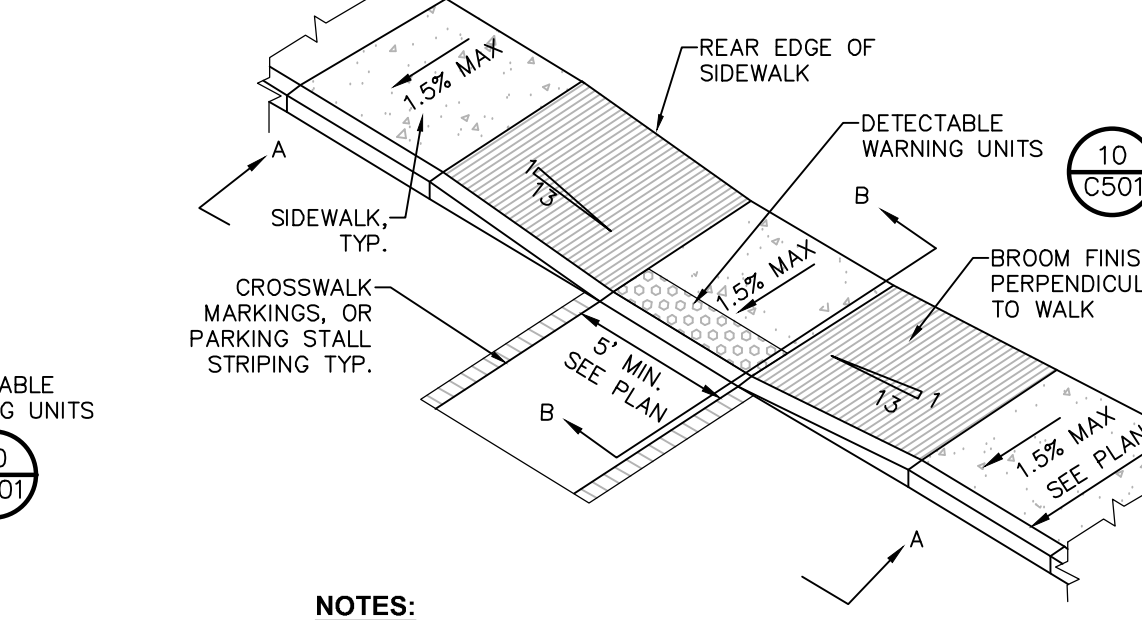
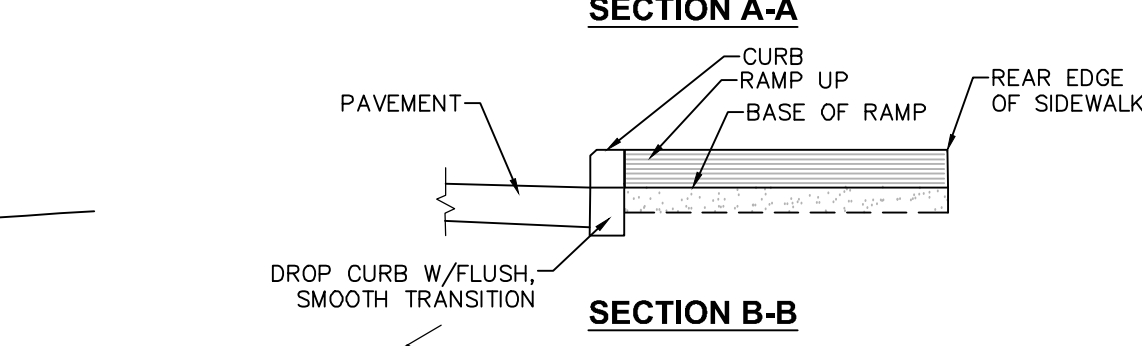
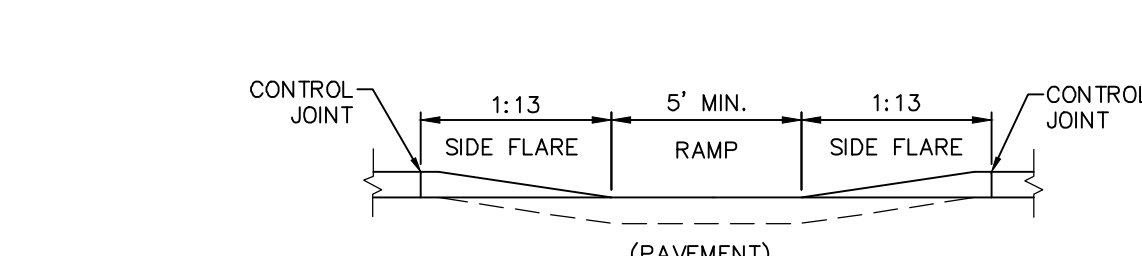

NOTES:
 1. ALL WORK SHALL CONFORM WITH THE NYSDOT STANDARD SPECIFICATION FOR CONSTRUCTION AND MATERIALS DATED, "CURRENT VERSION", AND ALL ADDENDA THERE TO; SPECIFICALLY SECTION 608- SIDEWALKS, DRIVEWAYS, AND BICYCLE PATHS.
 2. SLOPE RAMP AND SIDE FLARES AS INDICATED IN THE PLANS OR AS ORDERED BY THE ENGINEER.
 3. DETECTABLE WARNING UNITS SHALL BE PROVIDED ON ALL RAMPS IN ACCORDANCE W/ ADA REQUIREMENTS.

8 PEDESTRIAN RAMP SECTION - DROP CURB
 SCALE: NOT TO SCALE

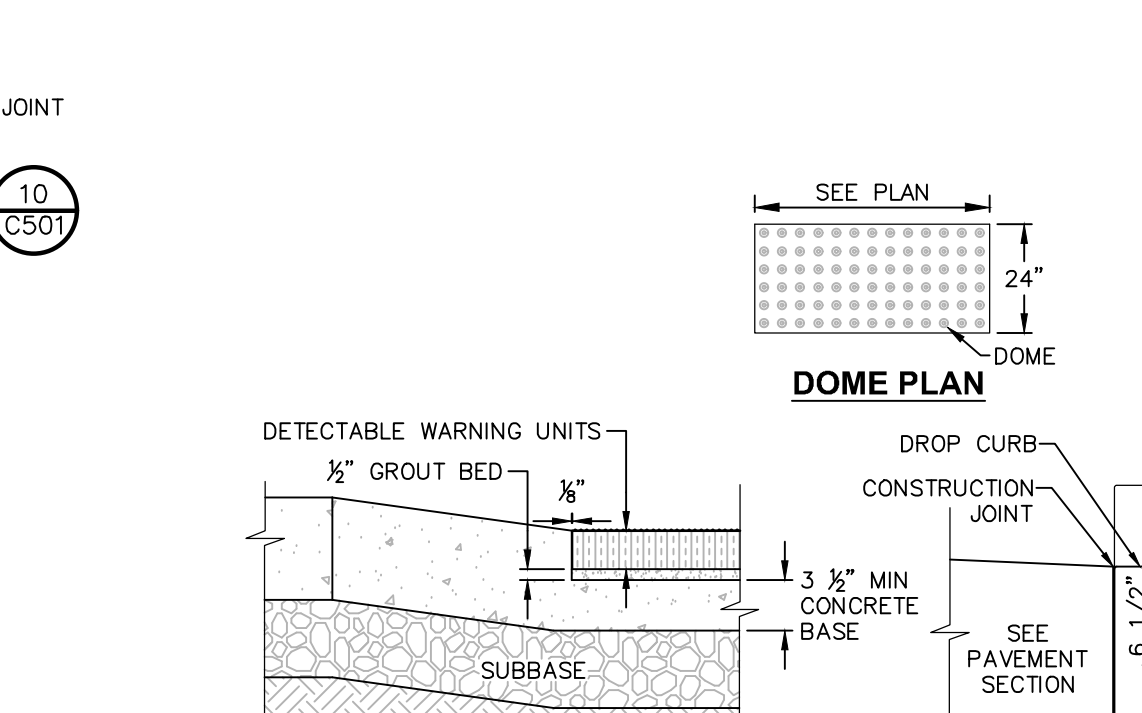

NOTES:
 1. GRANITE CURB TO BE INSTALLED IN ACCORDANCE WITH NYSDOT STANDARD SPECIFICATION SECTION 609.

12 GRANITE CURB AT SIDEWALK
 SCALE: NOT TO SCALE

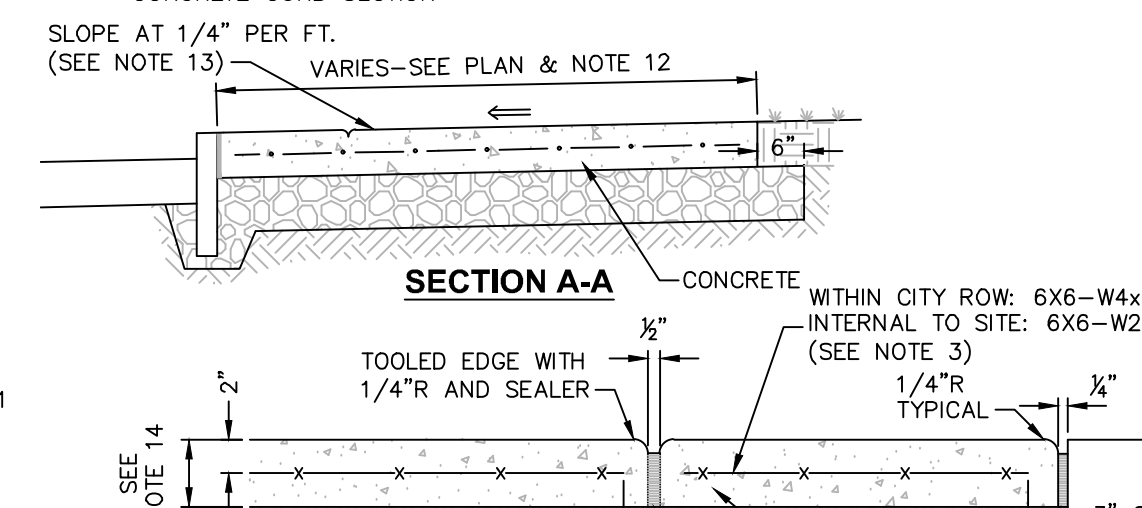
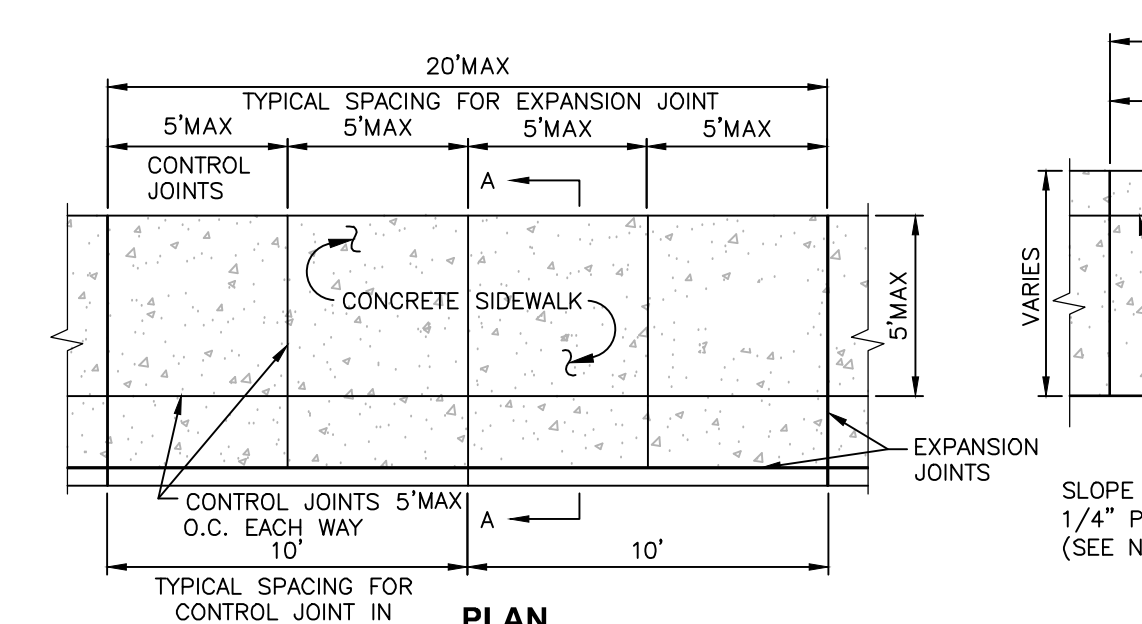

NOTES:
 1. GRANITE CURB TO BE INSTALLED IN ACCORDANCE WITH NYSDOT STANDARD SPECIFICATION SECTION 609.

13 GRANITE CURB
 SCALE: NOT TO SCALE

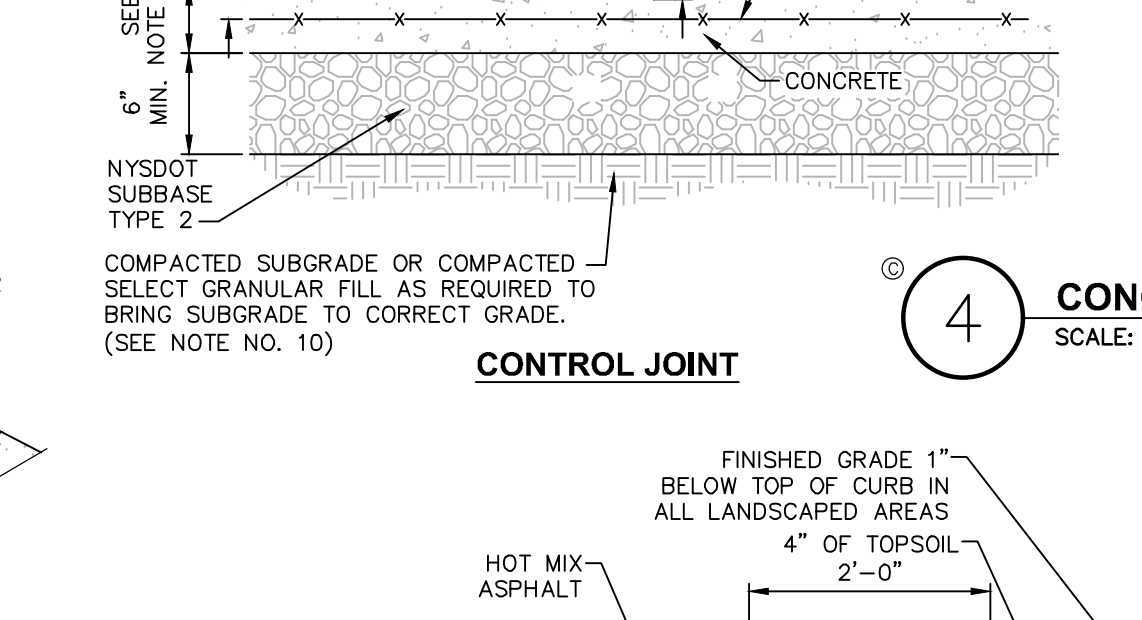
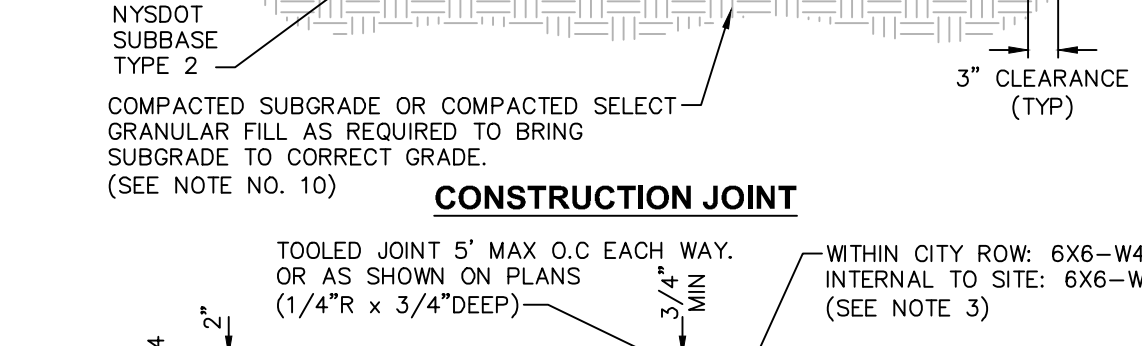
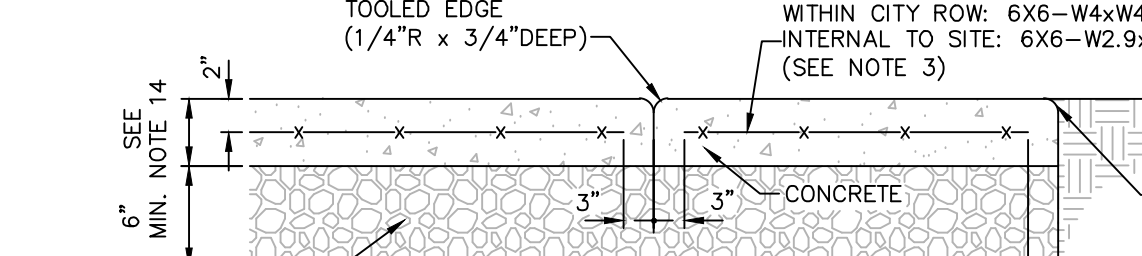

NOTES:
 1. GRANITE CURB TO BE INSTALLED IN ACCORDANCE WITH NYSDOT STANDARD SPECIFICATION SECTION 609.

15 UNIT PAVERS OVER CONCRETE BASE
 SCALE: NOT TO SCALE

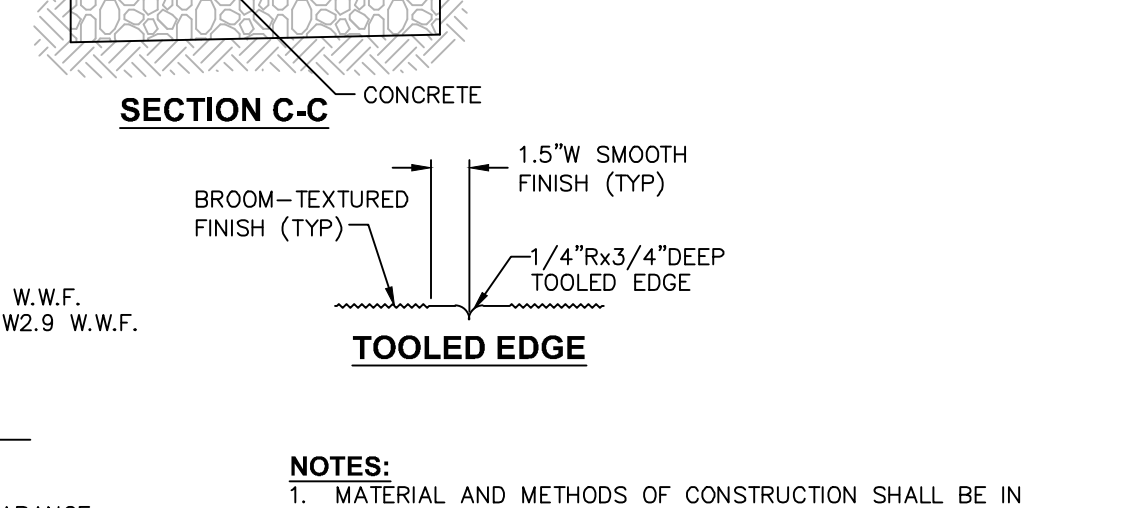
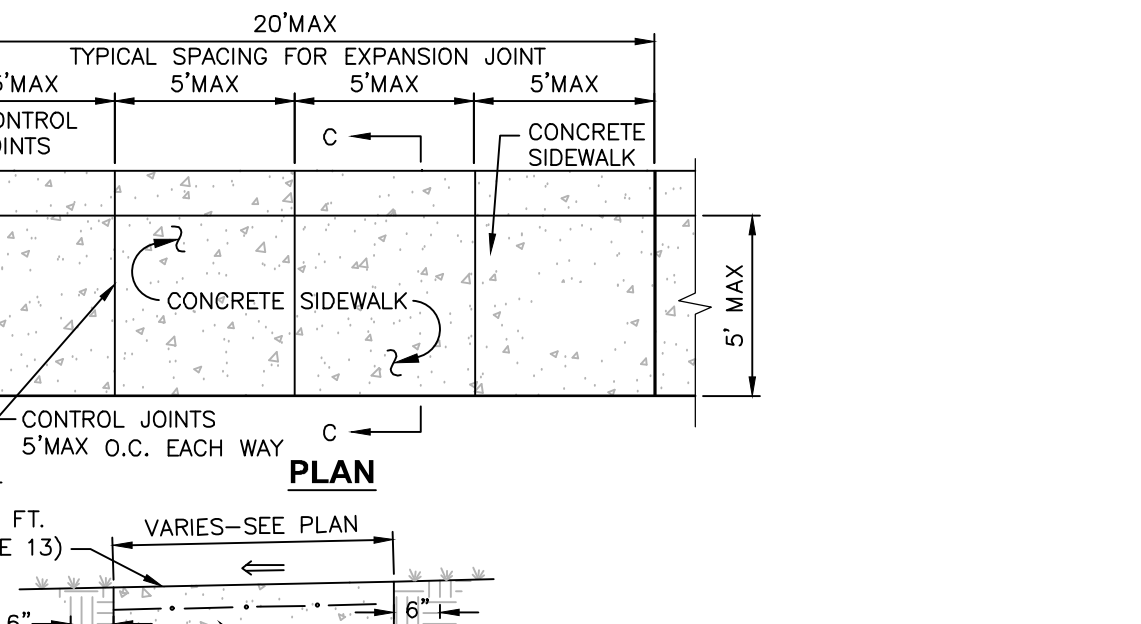

NOTES:
 1. MATERIAL AND METHODS OF CONSTRUCTION SHALL BE IN CONFORMANCE WITH THE NEW YORK STATE DEPARTMENT OF TRANSPORTATION (NYSDOT) STANDARD SPECIFICATIONS FOR CONSTRUCTION AND MATERIALS, LATEST VERSION, AND ALL ADDENDA THERE TO.
 2. ALL CONCRETE SHALL BE PORTLAND CEMENT, AIR-ENTRAINED, 4,500 CONCRETE WITH AN AIR CONTENT OF 5% MIN., TO 7% MAX., AND A SLUMP OF THREE INCHES, MIN., TO FIVE INCHES, MAX.
 3. REINFORCING STEEL FOR CONCRETE SHALL CONFORM WITH SECTION 556 - REINFORCING STEEL FOR CONCRETE STRUCTURES OF THE ABOVE REFERENCED NYSDOT STANDARD SPECIFICATIONS AND AS SPECIFICALLY CALLED OUT IN THE DRAWINGS. CONFORM TO CITY OF ALBANY STANDARDS FOR WORK WITHIN RIGHT-OF-WAY.
 4. ALL SIDEWALKS SHALL BE FINISHED WITH A MAGNESIUM FLOAT FINISH, UNLESS DIRECTED OTHERWISE BY THE CITY OF ALBANY.
 5. ALL EXPOSED SURFACES SHALL HAVE A BROOM TEXTURED FINISH & TOOLED EDGES. TOOL SHALL BE PROVIDE MAX 1-1/2" WIDE SMOOTH TROWEL FINISH AT JOINT.
 6. EXPANSION JOINTS SHALL BE LOCATED A MAXIMUM OF 20' ON CENTER, OR AS INDICATED ON PLANS, AND PLACED BETWEEN ADJACENT SLABS, AT BUILDING LINE, AT CURBS, OR AT PENETRATING STRUCTURES.
 7. JOINTS SHALL NOT BE SAW CUT.
 8. EXPOSED CONCRETE SURFACES SHALL BE TREATED WITH "SUREBOND"/"SAFEbond" SB-7000 INTENSIFIER BRIGHT PROTECTOR AND SIDEWALK SEALER, OR EQUAL. RATE AND METHOD OF APPLICATION SHALL BE IN ACCORDANCE WITH MANUFACTURER'S RECOMMENDATIONS.
 9. SUBBASE MATERIAL SHALL CONFORM WITH SECTION 304 OF THE ABOVE REFERENCED NYSDOT STANDARD.
 10. WHERE IT IS NECESSARY TO PLACE FILL FOR PURPOSE OF BRINGING THE SUBGRADE ELEVATION UP TO A SPECIFIED GRADE, THE FILL MATERIAL PLACED SHALL BE IN ACCORDANCE WITH SECTION 203-EXCAVATION AND EMBANKMENT OF THE ABOVE REFERENCED NYSDOT STANDARD SPECIFICATIONS.
 11. ALL WORK SHALL CONFORM WITH SECTION 608-SIDEWALK, DRIVEWAYS, AND BICYCLE PATHS OF THE ABOVE REFERENCED NYSDOT STANDARD SPECIFICATIONS. UNLESS OTHERWISE NOTED, ALL ITEMS ASSOCIATED WITH SIDEWALK INSTALLATION SHALL BE PAID FOR UNDER ITEM 608.0101.
 12. SIDEWALK WIDTH SHOWN ON THE PLANS IS TO BE MEASURED FROM THE BACK OF THE CURB.
 13. SIDEWALKS SHALL HAVE A CROSS SLOPE OF 1.5%-2.0% UNLESS OTHERWISE NOTED ON PLAN.
 14. SIDEWALKS IN DRIVEWAYS OR TRAFFIC AREAS SHALL HAVE A THICKNESS OF 6" INCHES. SIDEWALKS IN ALL OTHER AREAS SHALL BE 4" INCHES THICK.

5 CONCRETE DRIVEWAY APRON DETAIL
 SCALE: NOT TO SCALE

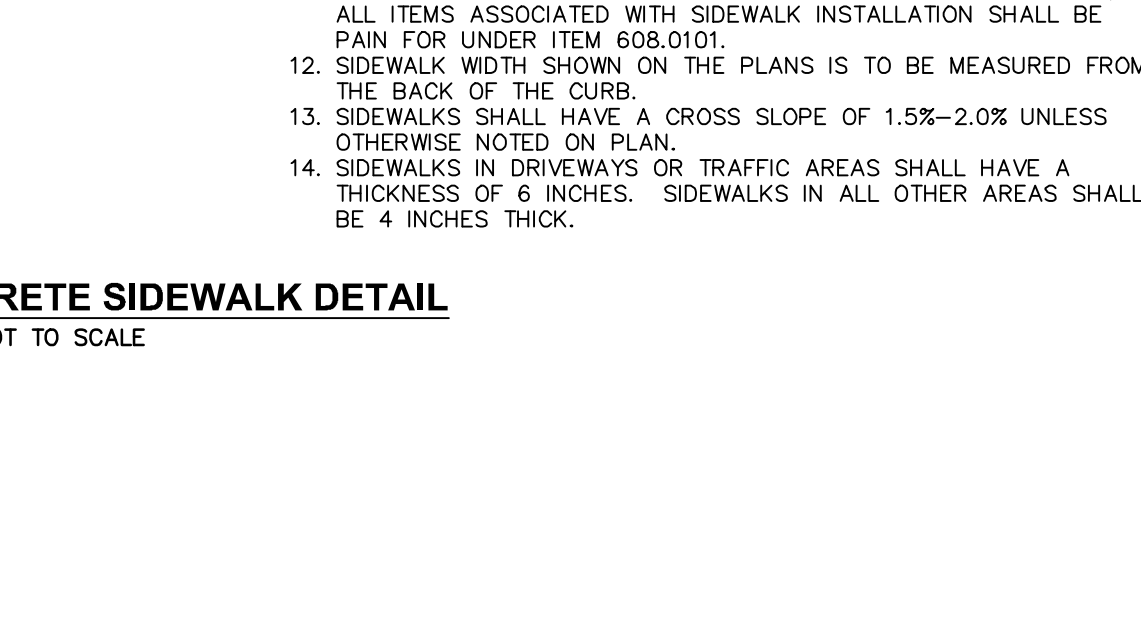
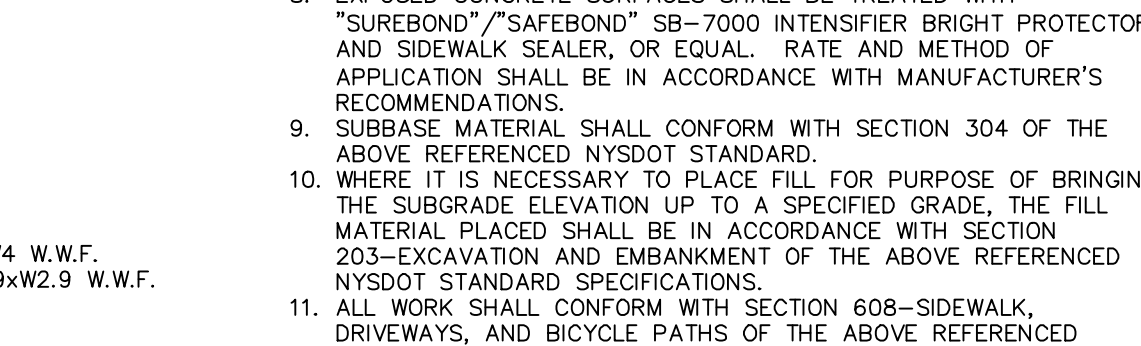
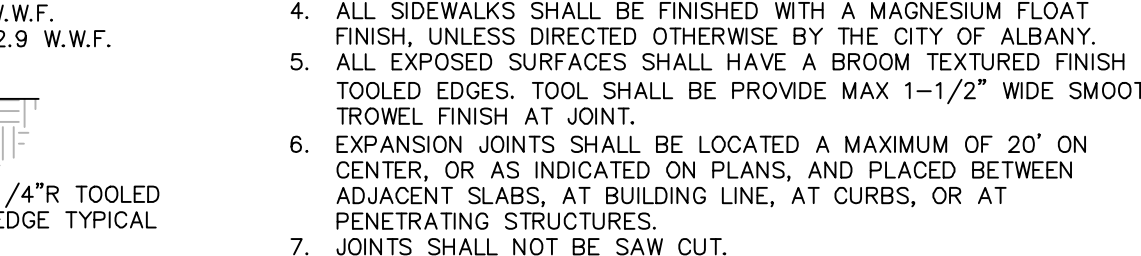

NOTES:
 1. ALL WORK SHALL CONFORM WITH THE NYSDOT STANDARD SPECIFICATION FOR CONSTRUCTION AND MATERIALS DATED, "CURRENT VERSION", AND ALL ADDENDA THERE TO; SPECIFICALLY SECTION 608- SIDEWALKS, DRIVEWAYS, AND BICYCLE PATHS.
 2. SLOPE RAMP AND SIDE FLARES AS INDICATED IN THE PLANS OR AS ORDERED BY THE ENGINEER.
 3. DETECTABLE WARNING UNITS SHALL BE PROVIDED ON ALL RAMPS IN ACCORDANCE W/ ADA REQUIREMENTS.

4 CONCRETE SIDEWALK DETAIL
 SCALE: NOT TO SCALE

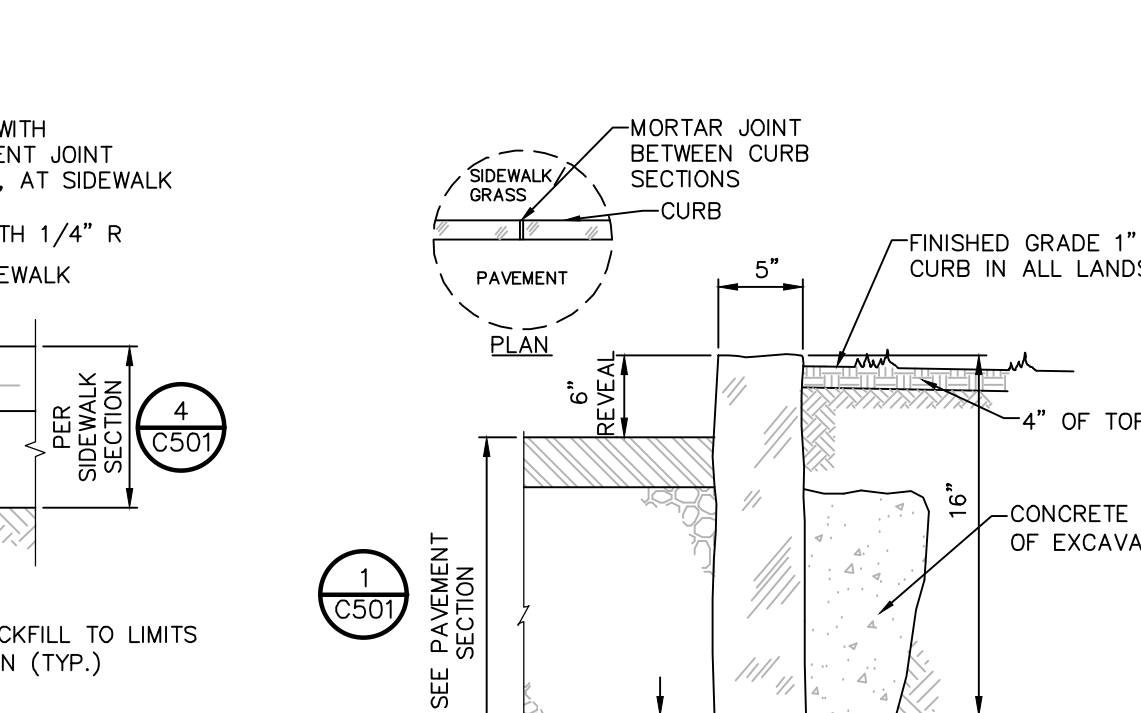

NOTES:
 1. GRANITE CURB TO BE INSTALLED IN ACCORDANCE WITH NYSDOT STANDARD SPECIFICATION SECTION 609.

13 GRANITE CURB
 SCALE: NOT TO SCALE

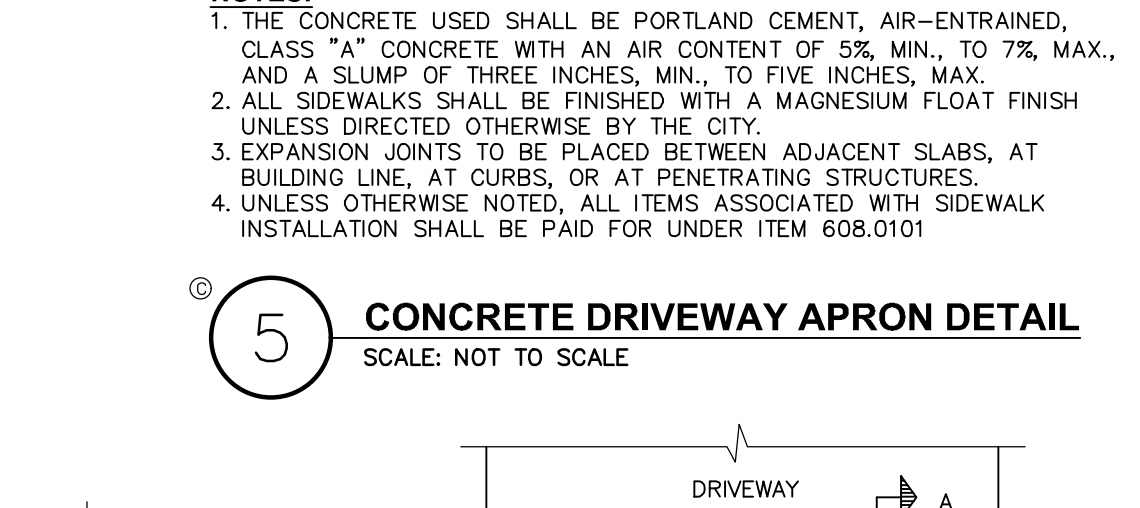
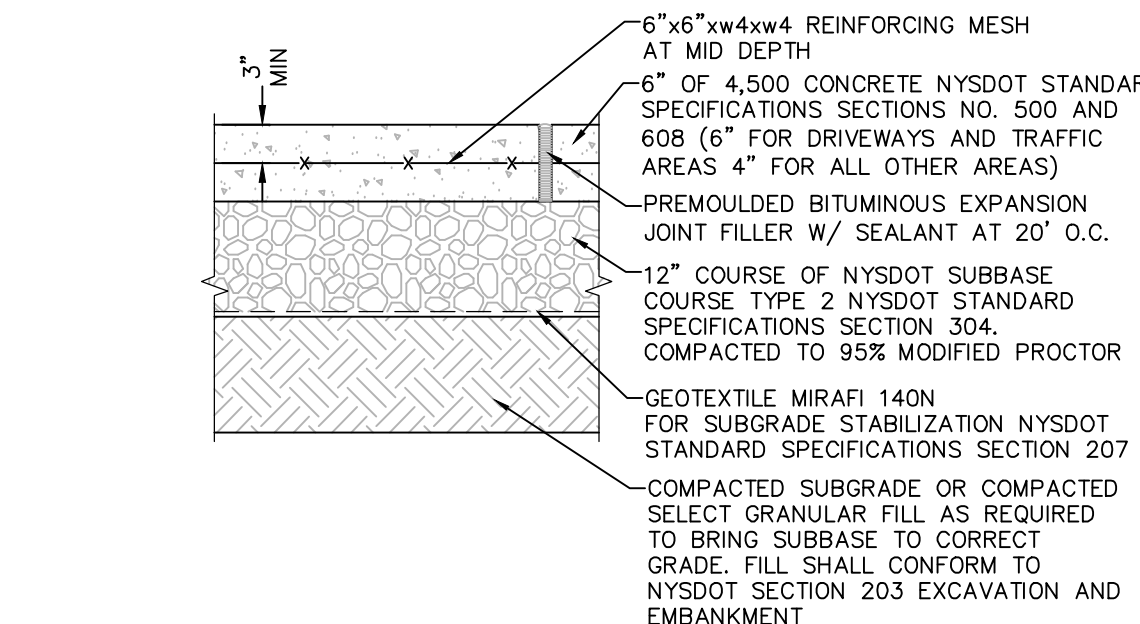

NOTES:
 1. CURB REVEALS SHALL BE 1/2" MAX. WHERE RAMP MEETS PAVEMENT AT ROADWAY.
 2. SIDEWALK SHALL BE INSTALLED FLUSH WITH EXISTING DRIVEWAY.
 3. SIDEWALK SHALL BE 6" THICK AT DRIVEWAY APRONS.
 4. SEE STANDARD SIDEWALK DETAIL FOR SIDEWALK INSTALLATION.

6 DRIVEWAY RAMP WITH DROP CURB
 SCALE: NOT TO SCALE

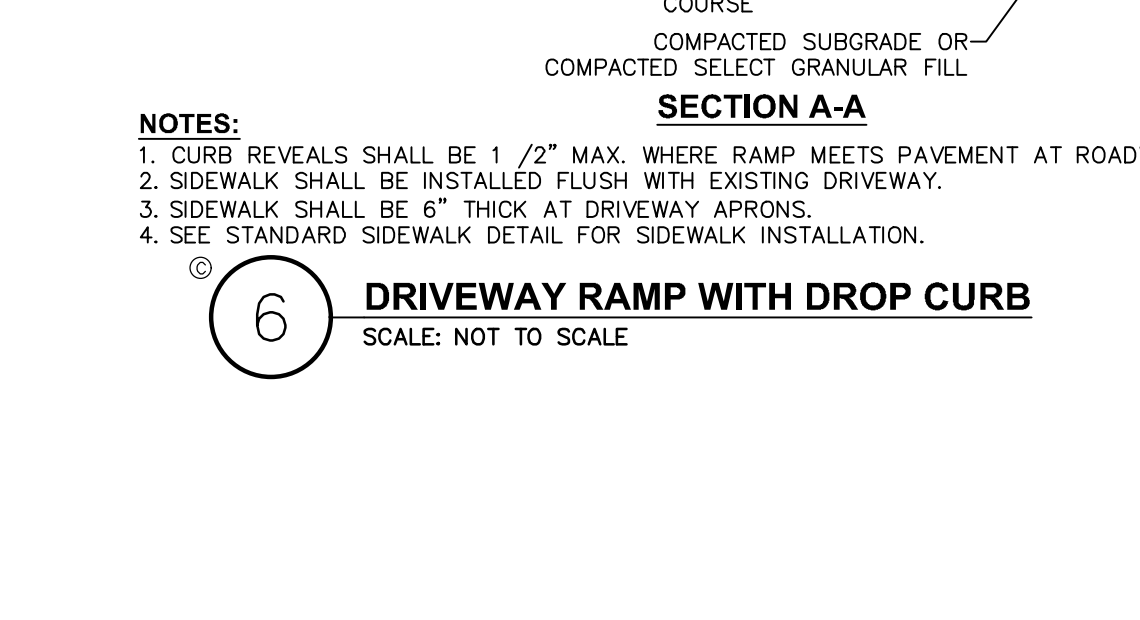
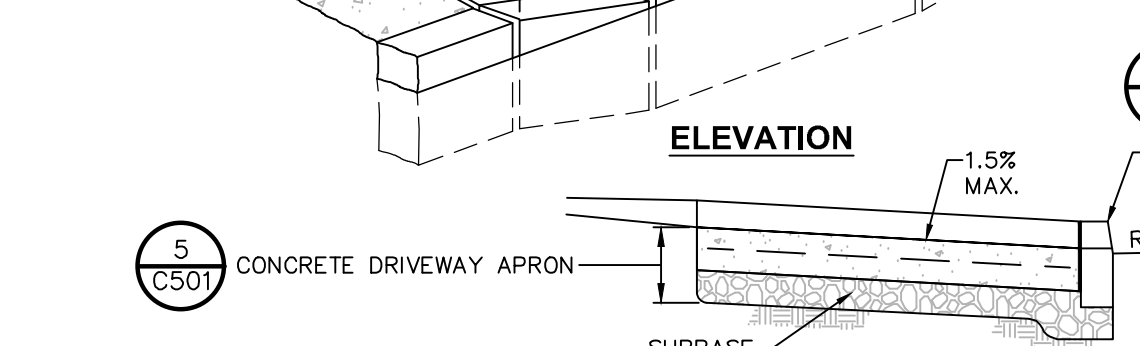
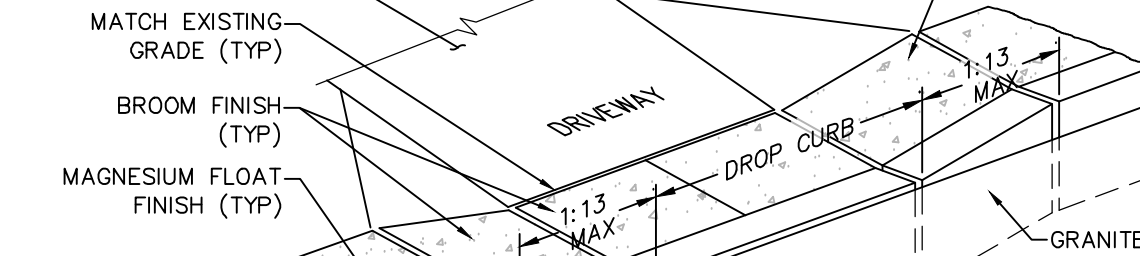

NOTES:
 1. CURB REVEALS SHALL BE 1/2" MAX. WHERE RAMP MEETS PAVEMENT AT ROADWAY.
 2. SIDEWALK SHALL BE INSTALLED FLUSH WITH EXISTING DRIVEWAY.
 3. SIDEWALK SHALL BE 6" THICK AT DRIVEWAY APRONS.
 4. SEE STANDARD SIDEWALK DETAIL FOR SIDEWALK INSTALLATION.

14 UNIT PAVERS ON SAND SETTING BED
 SCALE: NOT TO SCALE

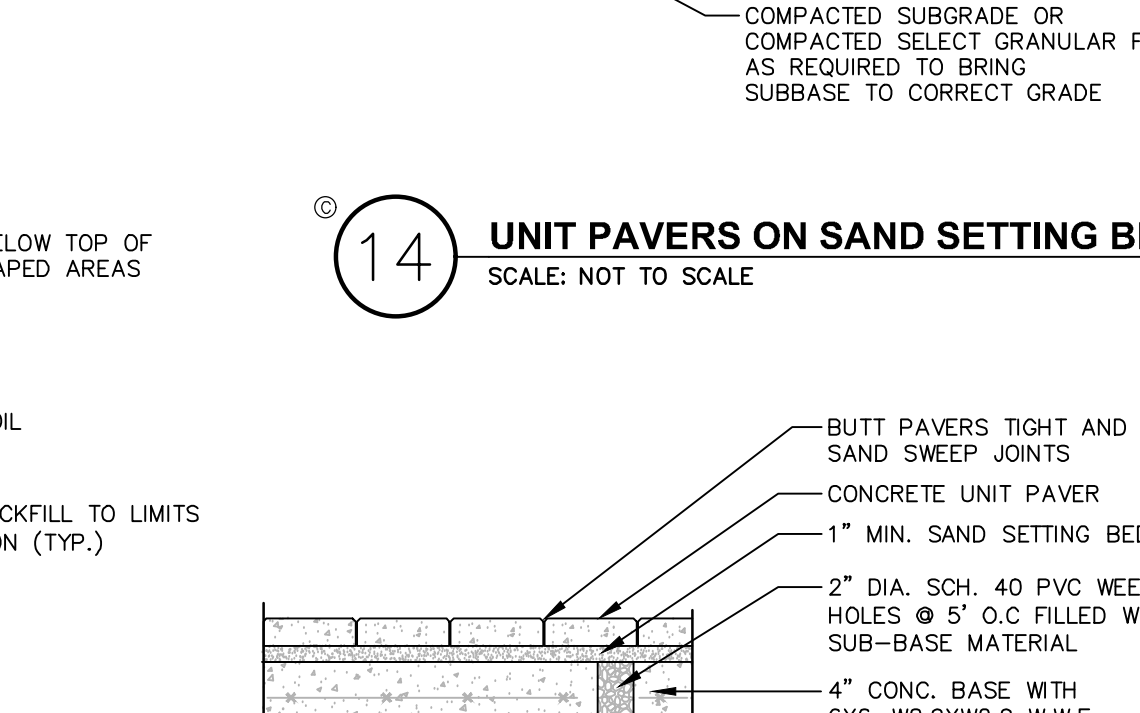

NOTES:
 1. GRANITE CURB TO BE INSTALLED IN ACCORDANCE WITH NYSDOT STANDARD SPECIFICATION SECTION 609.

15 UNIT PAVERS OVER CONCRETE BASE
 SCALE: NOT TO SCALE

THE SEVENTY-SIX

Parcel 76, 76 Second Avenue, City of Albany, NY

Owner: South End Development LLC

Architect: Garrison-Architects
 45 Main Street
 Brooklyn, NY 11201

Civil Engineer: The Chazen Companies
 547 River St.
 Troy, NY 12180
 p (518) 273-0055
 Chazen Project No. 32019.00

Revision Schedule

Revision Number	Revision Description	Revision Date

Schematic Design

Scale: AS NOTED
 Date: 06/23/2020
 Project No: 2005
 Drawn by: KC/SM
 Checked by: RK

Seal & Signature:

DOB Stamp & Signature

DOB Scan:

Drawing Title: Site Details

Drawing Number: **C-501**

DWG.No:

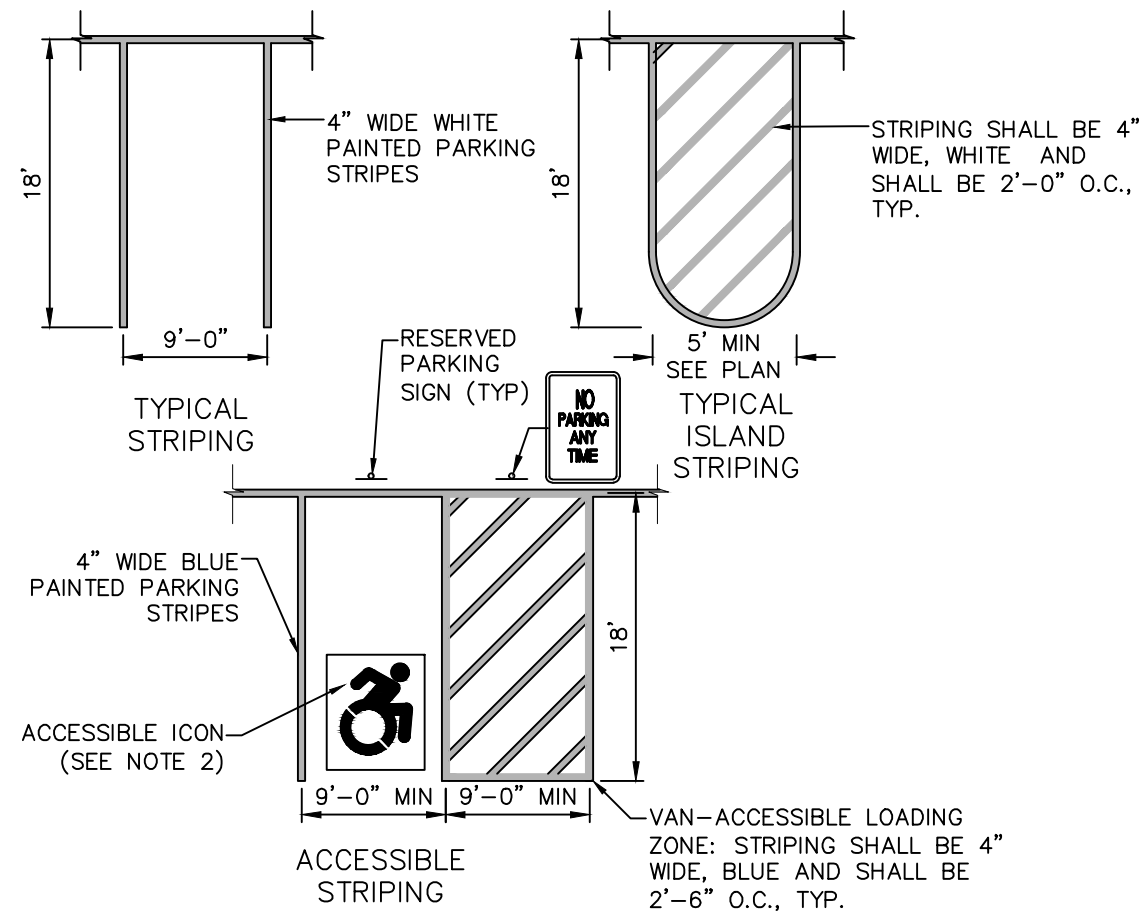

- NOTES:**
1. ALL DIMENSIONS SHALL BE IN ACCORDANCE WITH ADA STANDARD AND CURRENT ZONING AND SITE REGULATIONS.
 2. PAINTED ACCESSIBLE LOGO TO BE IN ACCORDANCE W/ NEW YORK STATE LAW.
 3. SLOPE OF PAVEMENT SURFACE IN ACCESSIBLE PARKING AREA SHALL NOT EXCEED 1.5% IN ANY DIRECTION.
 4. SEE PLAN FOR ACTUAL LOCATION OF SIGNAGE.

1 **PAVEMENT MARKING DETAIL PARKING STRIPING**
SCALE: NOT TO SCALE

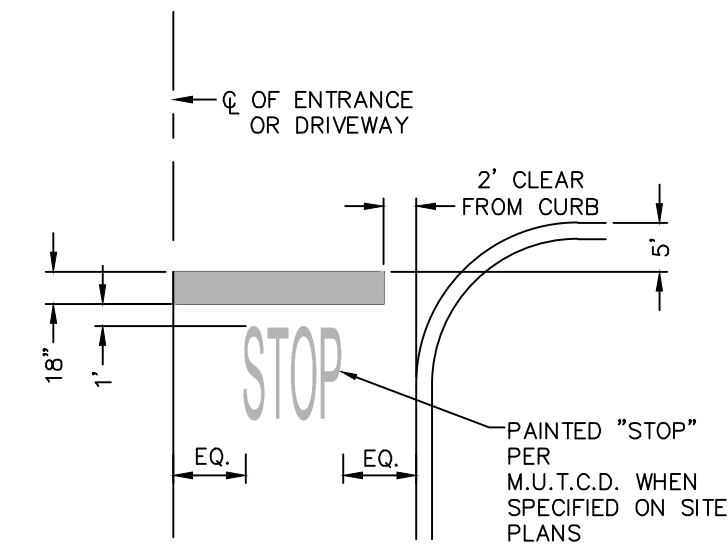

2 **PAVEMENT MARKING DETAIL STOP BAR**
SCALE: NOT TO SCALE

- STRIPING NOTES:**
1. ALL STRIPING SHALL CONFORM TO THE LATEST EDITION OF THE NYS DOT STANDARD SPECIFICATIONS, SECTION 640 AND THE "NATIONAL MANUAL ON UNIFORM TRAFFIC CONTROL DEVICES" - 2009 EDITION AND THE "NYS SUPPLEMENT."
 2. STRIPE PAVEMENT AS INDICATED ON THE PLANS AND/OR IN ACCORDANCE WITH ALL APPLICABLE LOCAL, STATE AND FEDERAL REQUIREMENTS.
 3. STRIPING WORK WILL BE REVIEWED AND ACCEPTED BY THE AUTHORITY HAVING JURISDICTION.
 4. COLOR: DRIVE LANE DIVIDERS - WHITE OR AOBIE NO PARKING ZONE WARNINGS - WHITE OR AOBIE PARKING DIVIDERS - WHITE OR AOBIE WALKING LINES - WHITE OR AOBIE ACCESSIBLE PARKING LINES & SYMBOL - BLUE

- SIGNAGE NOTES:**
1. ALL SIGNS SHALL CONFORM TO THE LATEST EDITION OF THE NYS DOT STANDARD SPECIFICATIONS, SECTION 645 AND THE "NATIONAL MANUAL ON UNIFORM TRAFFIC CONTROL DEVICES" - 2009 EDITION AND THE "NYS SUPPLEMENT."
 2. SIGN MOUNTING HEIGHT SHALL BE A MINIMUM OF 7'. MINIMUM MOUNTING HEIGHT MAY BE ADJUSTED ONLY IN ACCORDANCE WITH PROVISIONS OUTLINED IN THE "NATIONAL MANUAL ON UNIFORM TRAFFIC CONTROL DEVICES" - 2009 EDITION AND THE "NYS SUPPLEMENT."
 3. SIGN POST SHALL BE IN ACCORDANCE W/ NYS DOT STANDARD SPECS SECTION 730.

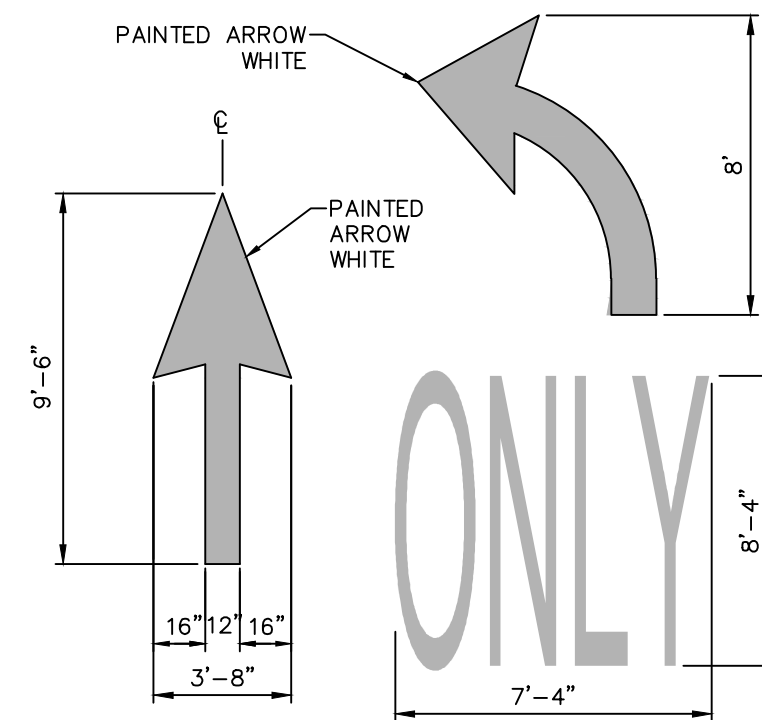

3 **PAVEMENT MARKING DETAIL DIRECTIONAL ARROW**
SCALE: NOT TO SCALE

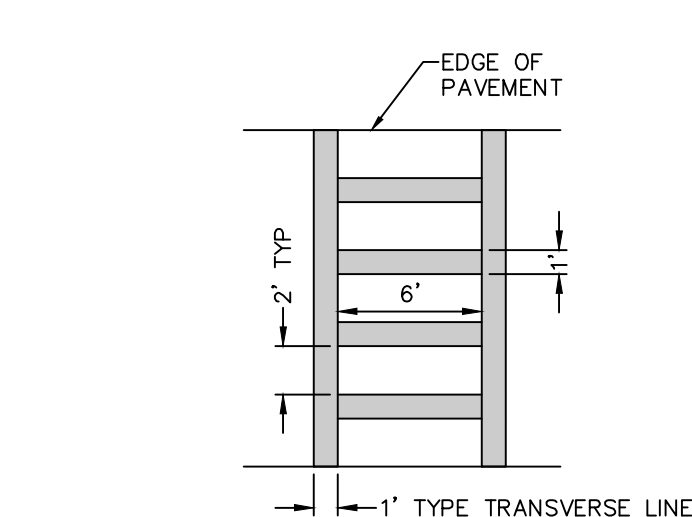

- NOTES:**
1. ALL CROSS WALK STRIPING SHALL BE WHITE.
 2. TYPE LS CROSS WALK SHALL BE USED IN HIGH TRAFFIC VOLUME STREET CROSSINGS.

4 **PAVEMENT MARKING DETAIL CROSS WALK STRIPING**
SCALE: NOT TO SCALE

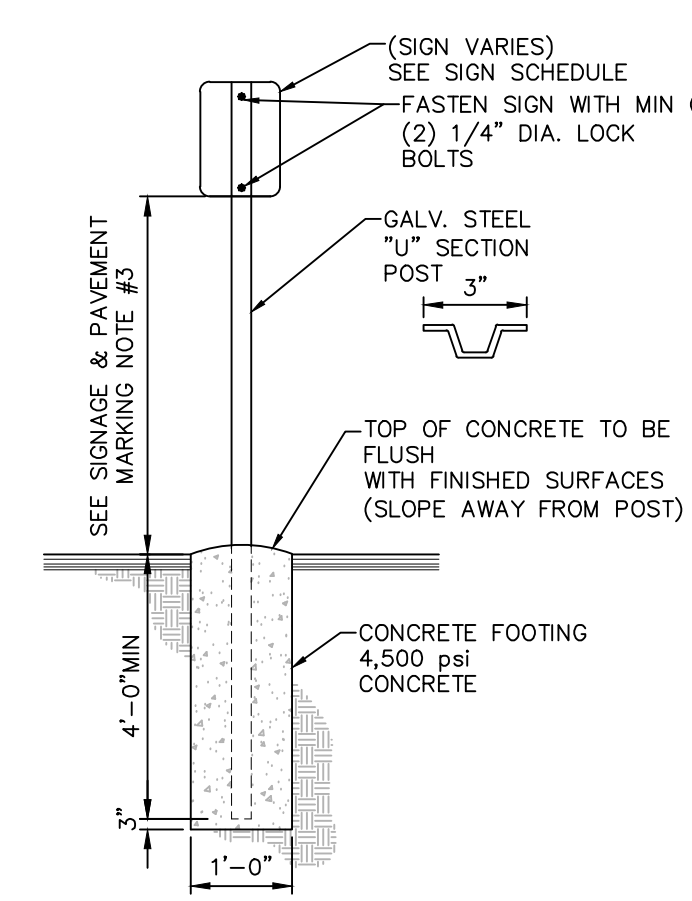

5 **SINGLE POST IN CONCRETE SIGN MOUNTING DETAIL**
SCALE: NOT TO SCALE

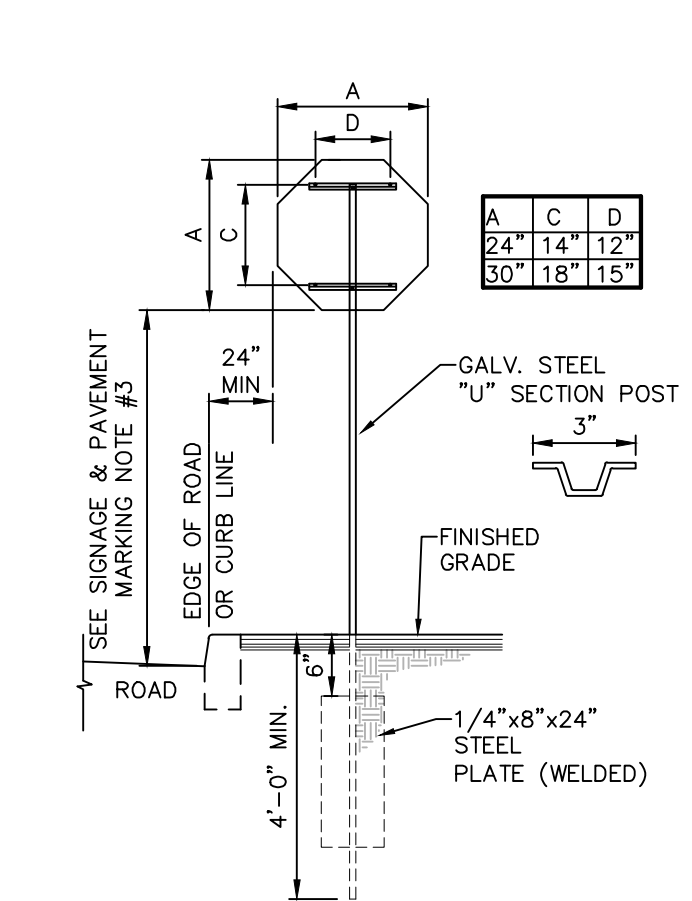

6 **SINGLE POST STOP SIGN MOUNTING DETAIL**
SCALE: NOT TO SCALE

MUTCD SIGN SCHEDULE						
SIGN NO.	SIGN FACE	MUTCD NUMBER	MIN SIZE	COLORS	LEGEND	MOUNTING
1	STOP	R1-1	30"x30"	RED	WHITE	6 (C500)
2	ONE WAY	R6-1L	36"x12"	BLACK	WHITE	6 (C500)
3	ONE WAY	R6-1R	36"x12"	BLACK	WHITE	6 (C500)
4	PEDESTRIAN	W11-2	24"x24"	YELLOW/ FYG	BLACK	6 (C500)
5	LEFT TURN	W16-7P	24"x12"	YELLOW/ FYG	BLACK	6 (C500)
6	SPEED LIMIT 30	R2-1	18"x24"	WHITE	BLACK	6 (C500)
7	DO NOT ENTER	R5-1	30"x30"	RED	WHITE	6 (C500)
8	RESERVED PHONE	NY R7-8D	12"x18"	WHITE/ BLUE	GREEN/ WHITE	5 (C500)
9	VAN ACCESSIBLE	R7-8P	12"x6"	WHITE	BLUE	5 (C500)
10	NO PARKING ANY TIME	R7-1	12"x18"	WHITE	RED	5 (C500)
11	NO PARKING	R3-2	30"x30"	WHITE	BLACK/ RED	6 (C500)
12	ELECTRIC VEHICLE CHARGING STATION	AS SHOWN	12"x18"	WHITE	GREEN	5 (C500)

7 **MUTCD SIGN SCHEDULE**
SCALE: NOT TO SCALE

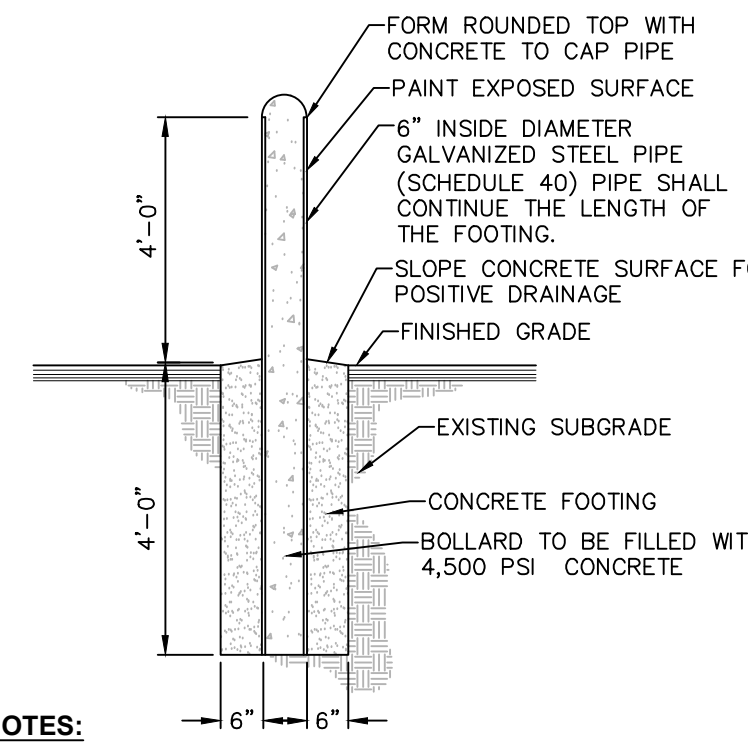

- NOTES:**
1. BOLLARD FINISH: PREPARE GALVANIZED COATING TO RECEIVE PAINTED FINISH. APPLY (1) COAT OF RUST INHIBITOR PRIMER. APPLY (2) COATS OF GLOSS ENAMEL (COLOR TO BE SELECTED BY THE OWNER).
 2. ALL CONCRETE SHALL HAVE A MINIMUM COMPRESSIVE STRENGTH OF 4,500 PSI @ 28 DAYS.
 3. ALL CONCRETE SHALL HAVE A SLUMP OF NO GREATER THAN 4" (WITH A TOLERANCE OF 1").
 4. ALL CONCRETE SHALL HAVE A 5% ENTRAINED AIR (WITH A TOLERANCE OF 1%) CONFORMING WITH ASTM C260.

8 **STEEL & CONCRETE BOLLARD DETAIL**
SCALE: NOT TO SCALE

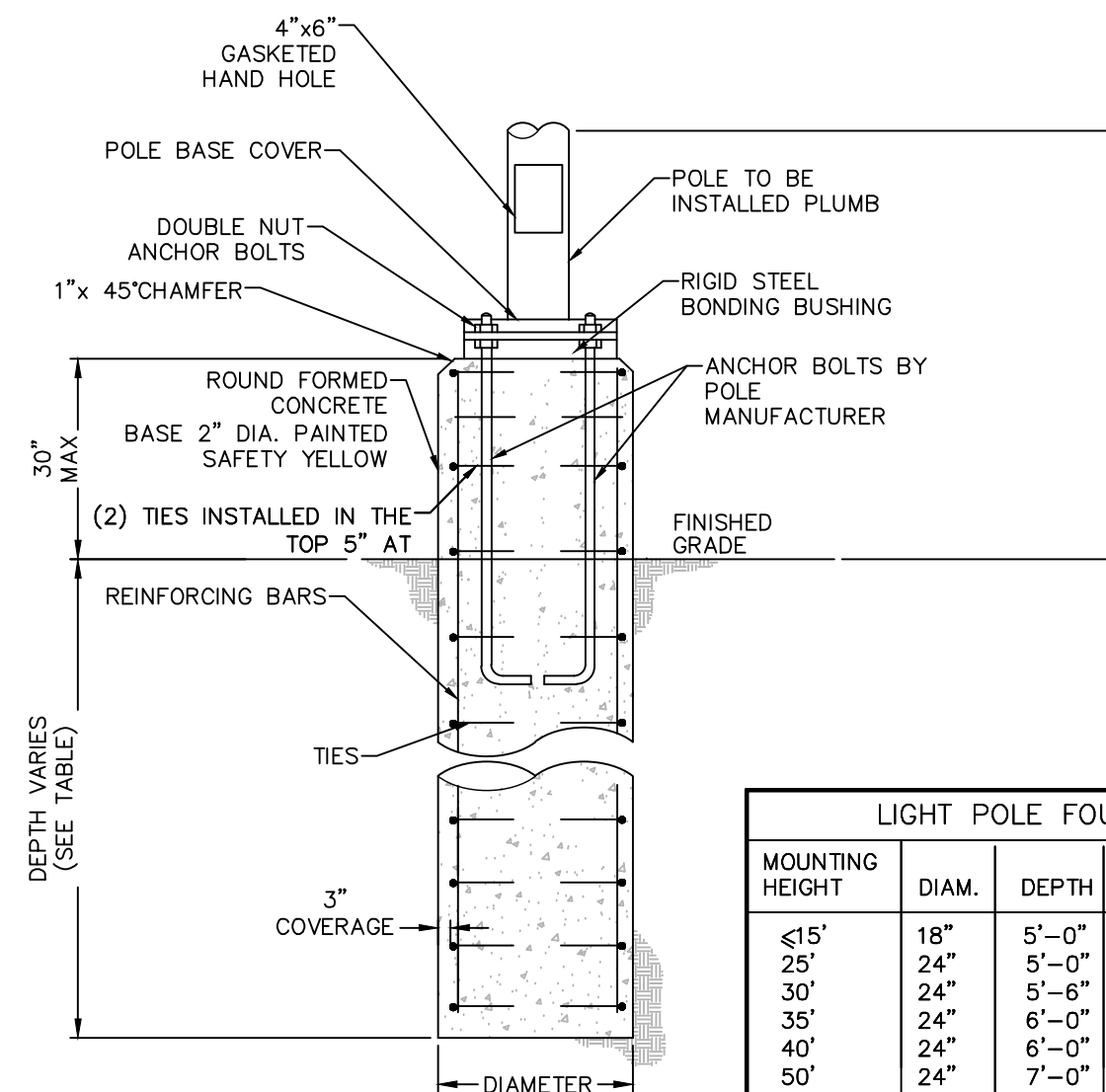

- NOTES:**
1. CONDUITS AND GROUNDING SHALL BE AS REQUIRED BY THE ELECTRICAL DESIGN.
 2. ALL CONCRETE SHALL BE 4,500 PSI @ 28 DAYS.
 3. ALL REINFORCING STEEL SHALL BE GRADE 60.
 4. DESIGNED FOR 90 MPH WIND WITH FIXTURE AREA OF 13 SF.
 5. FOUNDATION DIAMETER AND REINFORCING CIRCLE SHALL BE COORDINATED WITH ANCHOR BOLT LIMITS.
 6. FOUNDATIONS SHALL BE AUGERED INTO UNDISTURBED NATURAL SOIL OR COMPACTED FILL PER SITE GRADING P

9 **LOT LIGHTING CONCRETE BASE**
SCALE: NOT TO SCALE

LIGHT POLE FOUNDATIONS				
MOUNTING HEIGHT	DIAM.	DEPTH	REIN. BARS	TIES
≤15'	18"	5'-0"	(6)#6	#3@18"
25'	24"	5'-0"	(6)#6	#3@12"
30'	24"	5'-6"	(6)#6	#3@12"
35'	24"	6'-0"	(6)#6	#3@12"
40'	24"	6'-0"	(6)#6	#3@12"
50'	24"	7'-0"	(6)#8	#3@12"

THE SEVENTY-SIX

Parcel 76, 76 Second Avenue, City of Albany, NY

Owner: South End Development LLC

Architect: Garrison-Architects
45 Main Street
Brooklyn, NY 11201

Civil Engineer: The Chazen Companies
547 River St.
Troy, NY 12180
p (518) 273-0055
Chazen Project No. 32019.00

Revision Schedule

Revision Number	Revision Description	Revision Date

Schematic Design

Scale: AS NOTED
Date: 06/23/2020
Project No: 2005
Drawn by: KC/SM
Checked by: RK

Seal & Signature:

DOB Stamp & Signature

DOB Scan:

Drawing Title:
Site Details

Drawing Number:

C-502

DWG.No:

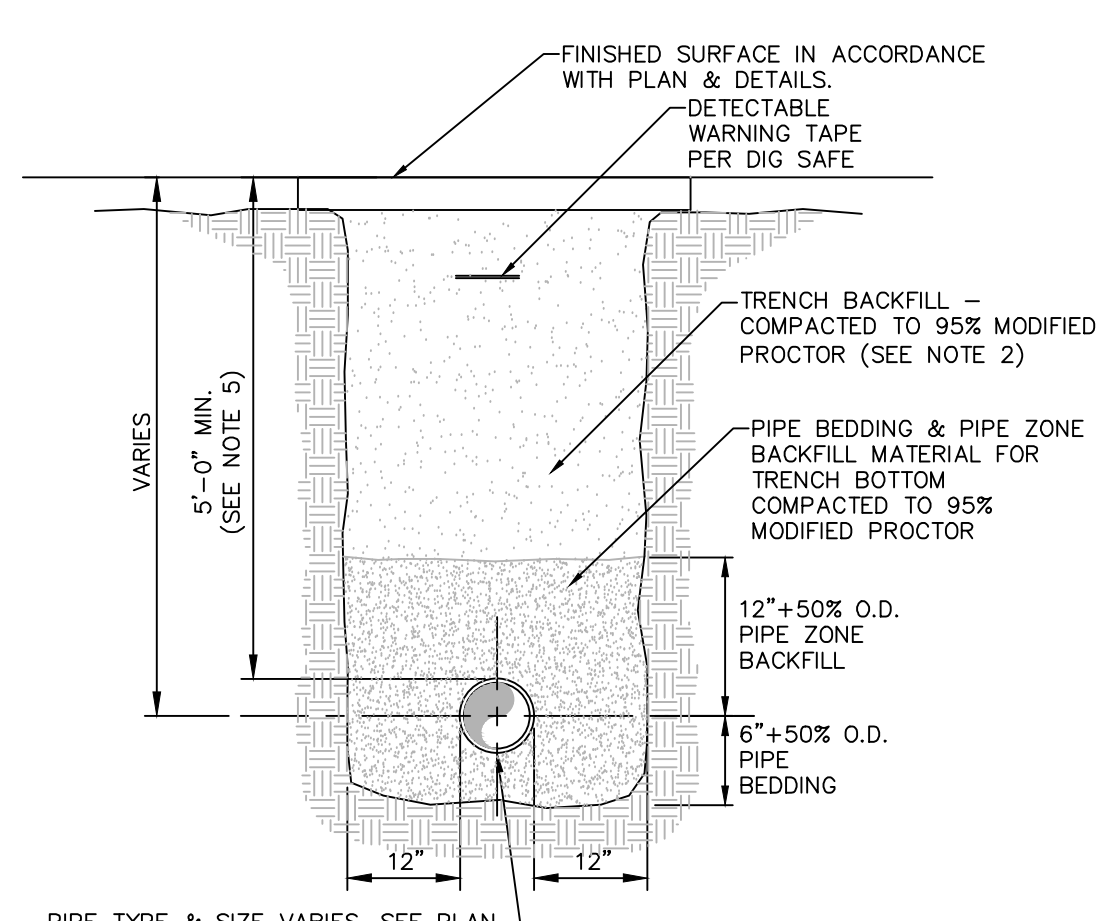

PIPE TYPE & SIZE VARIES. SEE PLAN

NOTES:

- PIPE BEDDING & PIPE ZONE BACKFILL SHALL BE A NATURAL RUN-OF-BANK (R.O.B.) SAND OR A MIXTURE OF CRUSHED STONE AND GRAVEL, FREE OF SOFT, NONDURABLE PARTICLES, ORGANIC MATERIALS AND ELONGATED PARTICLES, AND SHALL BE WELL GRADED FROM FINE TO COARSE PARTICLES. BEDDING GRADATIONS SHALL BE APPROVED BY THE ENGINEER AND SHALL MEET THE FOLLOWING GRADATION REQUIREMENTS:

SIEVE DESIGNATION	% PASSING
3/4"	100%
NO. 40	0-70%
NO. 200	0-10%

- TRENCH BACKFILL SHALL BE A NATURAL RUN-OF-BANK (R.O.B.) OR PROCESSED GRAVEL, OR EXCAVATED MATERIAL FREE OF SOFT, NONDURABLE PARTICLES, ORGANIC MATERIALS AND ELONGATED PARTICLES, AND SHALL BE WELL GRADED FROM FINE TO COARSE PARTICLES. BEDDING GRADATIONS SHALL BE APPROVED BY THE ENGINEER AND SHALL MEET THE FOLLOWING GRADATION REQUIREMENTS:

SIEVE DESIGNATION	% PASSING
4"	100%
NO. 40	0-70%
NO. 200	0-10%

IN NON-TRAFFIC UNPAVED AREAS TRENCH BACKFILL CAN BE MATERIALS EXCAVATED FROM THE TRENCH AS APPROVED BY THE ENGINEER AND COMPACTED TO 90% MODIFIED PROCTOR.

- INSTALL CONTINUOUS DETECTABLE MARKING TAPE DURING BACKFILLING OF TRENCH FOR UNDERGROUND PIPING. LOCATE TAPE 12" BELOW FINISHED GRADE, DIRECTLY OVER PIPING, EXCEPT 6" BELOW SUBGRADE UNDER PAVEMENTS & SLAB.
- TRENCHING SHALL BE IMPLEMENTED IN ACCORDANCE WITH O.S.H.A. STANDARDS.
- 5'-0" MIN COVER SHALL BE APPLIED TO WATER MAIN OR SANITARY SEWER FORCE MAINS ONLY.

1 PIPE TRENCH DETAIL (TYPICAL)
SCALE: NOT TO SCALE

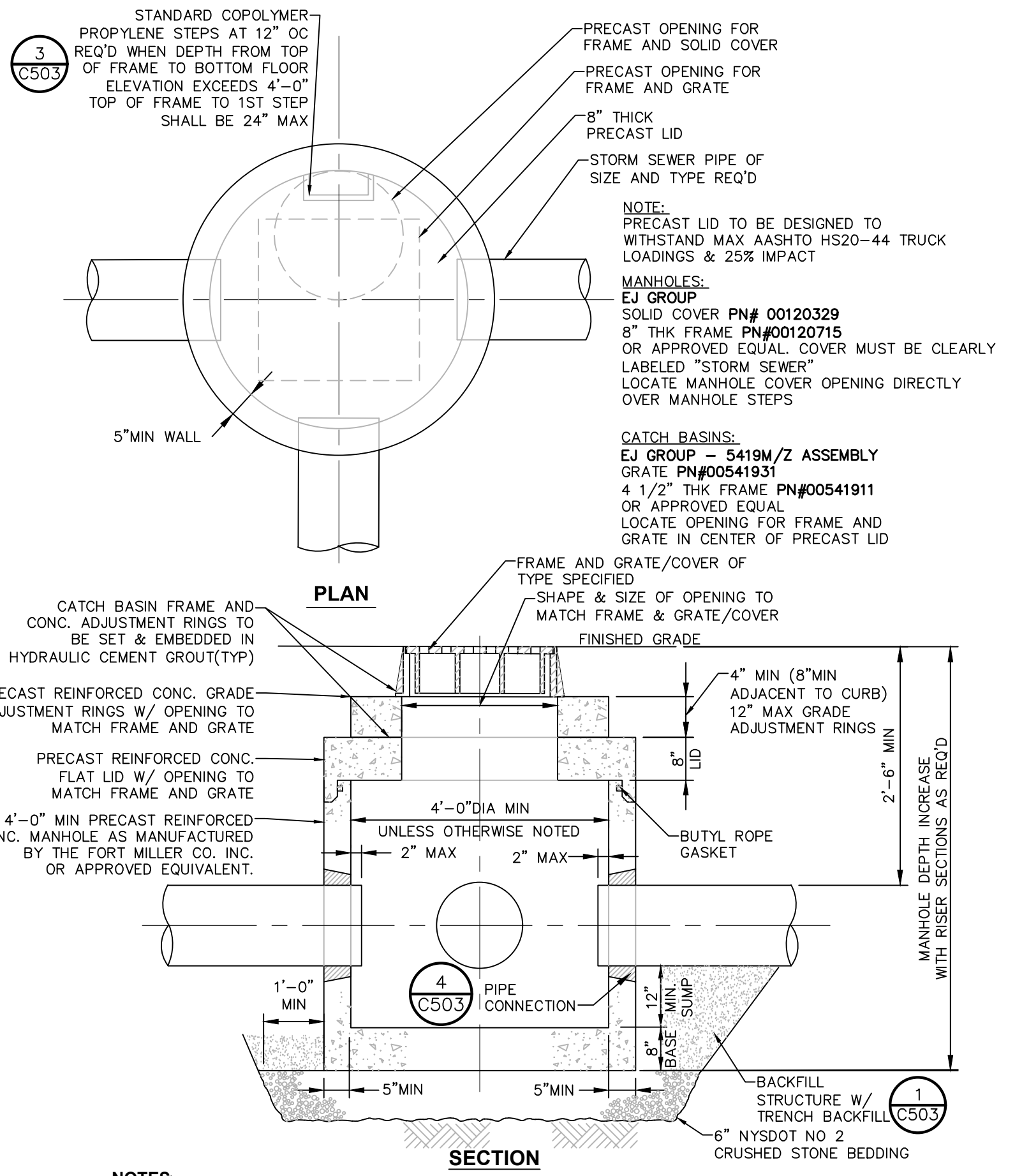

NOTES:

- CATCH BASIN SHALL BE PRECAST CONCRETE. DESIGNED FOR HS20-44 VEHICULAR LOADING AND 25% IMPACT.
- FRAME AND COVER SHALL BE DESIGNED FOR HS20-44 VEHICULAR LOADING & 25% IMPACT.
- CONCRETE CATCH BASIN LID CLEAR OPENING DIMENSION MUST MATCH FRAME AND GRATE CLEAR OPENING DIMENSION.
- CATCH BASINS HAVING A DEPTH GREATER THAN 48" FROM FINISHED SURFACE TO THE FLOOR OF THE CONCRETE BASE SHALL BE PROVIDED WITH STEPS.
- BACKFILL USING TRENCH BACKFILL, COMPACTED IN 6" LIFTS.
- SUMPS FOR CATCH BASINS SHALL BE 12".
- ECCENTRIC CONE TOP CAN BE USED FOR MANHOLES DEPTH GREATER THAN 7 FEET.
- SEE CHART FOR REQUIRED MANHOLES / CATCH BASINS DIAMETERS.
- ALL PRECAST CONSTRUCTION IN ACCORDANCE W/ASTM C478

2 PRECAST CONCRETE CATCH BASIN/MANHOLE DETAIL
SCALE: NOT TO SCALE

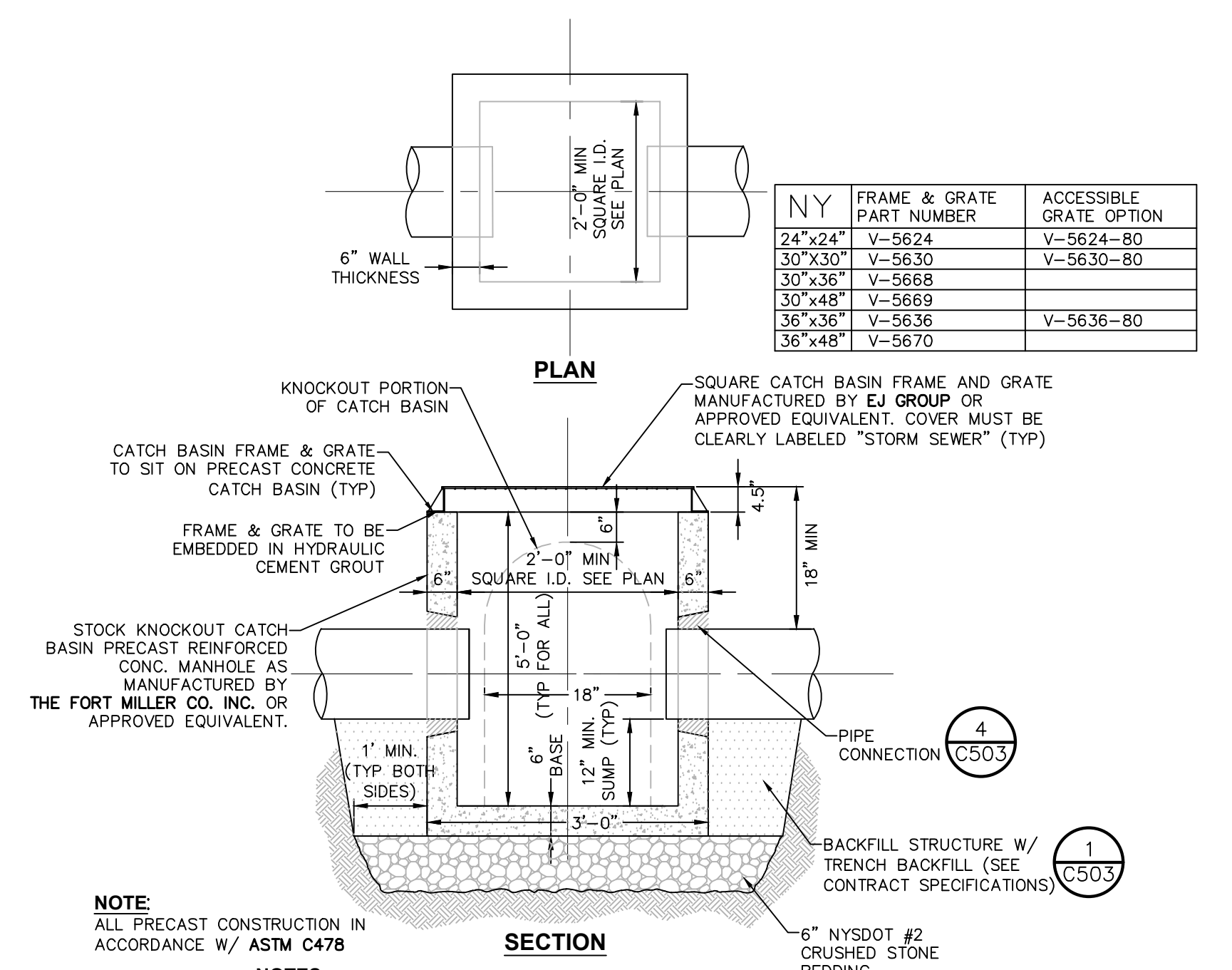

NOTE: ALL PRECAST CONSTRUCTION IN ACCORDANCE W/ ASTM C478

NOTES:

- CATCH BASIN INLET BASINS SHALL BE PRECAST CONCRETE, DESIGNED FOR HS20-44 VEHICULAR LOADING + 25% IMPACT AS MANUFACTURED BY FORT MILLER OR APPROVED EQUAL.
- CATCH BASIN SHALL NOT HAVE A DEPTH GREATER THAN 60" FROM FINISHED SURFACE.
- BACKFILL USING TRENCH BACKFILL, COMPACTED IN 6" LIFTS.
- MAX STORM SEWER PIPE FOR SHALLOW 2' CATCH BASIN IS 15"

3 PRECAST CONCRETE SHALLOW CATCH BASIN DETAIL
SCALE: NOT TO SCALE

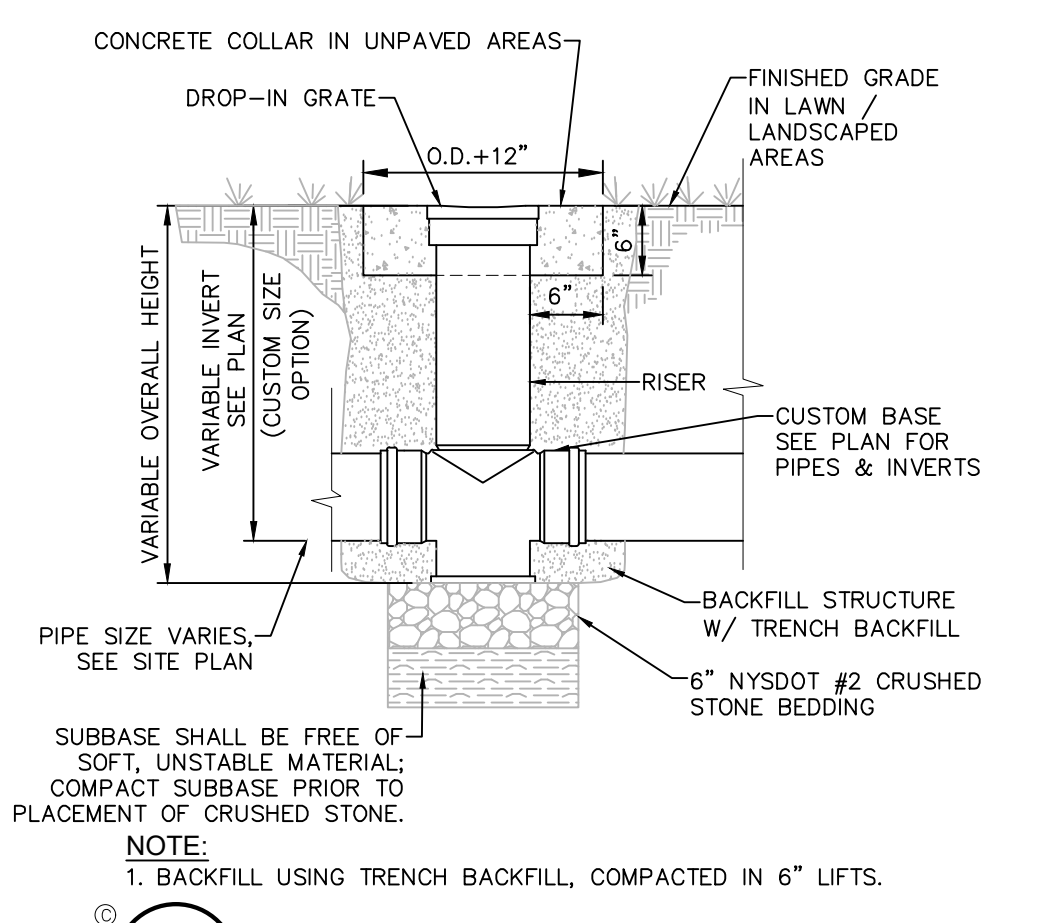

NOTE:

- BACKFILL USING TRENCH BACKFILL, COMPACTED IN 6" LIFTS.

4 NYOPLAST IN-LINE DRAIN BASIN
SCALE: NOT TO SCALE

ACCEPTABLE MANHOLE STEPS

MANUFACTURER	PATTERN NUMBER	"A" STEP WIDTH	"B" LEG LENGTH	"C" RUNG CLEAR	"D" EMBEDMENT	"E" RUNG CLEAR
M.A. INDUSTRIES INC*	PS2-PF	14 3/4	9 1/4	13 3/4	3 3/8	5 7/8
M.A. INDUSTRIES INC*	PS2-PFS	14 3/4	8 1/4	13 3/4	3 3/8	4 7/8

* OR EQUIVALENT

MH STEP DESIGN AND INSTALLATION SHALL COMPLY WITH ALL OSHA REGULATIONS

5 COPOLYMER POLYPROPYLENE MH STEP
SCALE: NOT TO SCALE

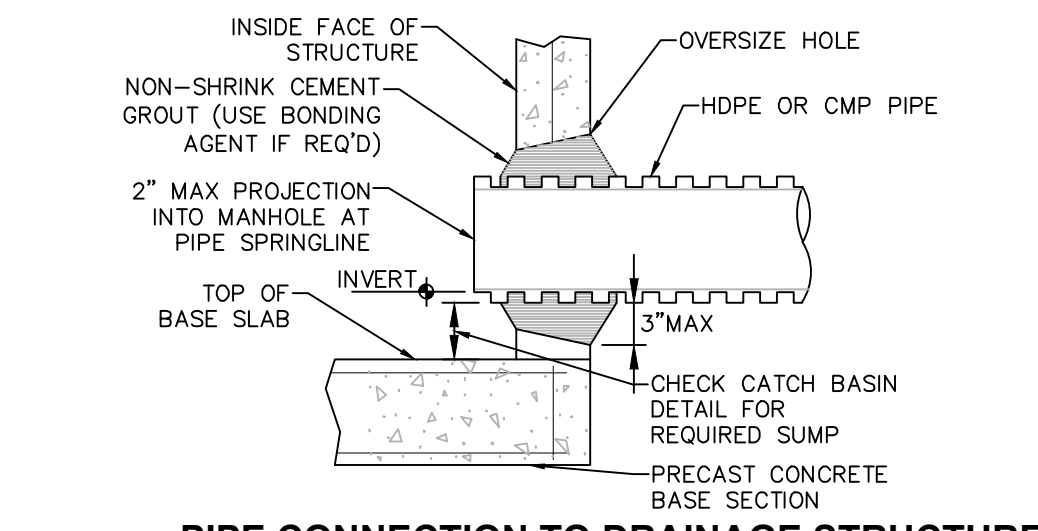

6 PIPE CONNECTION TO DRAINAGE STRUCTURE-CMP OR HDPE CEMENT GROUT SEAL JOINT
SCALE: NOT TO SCALE

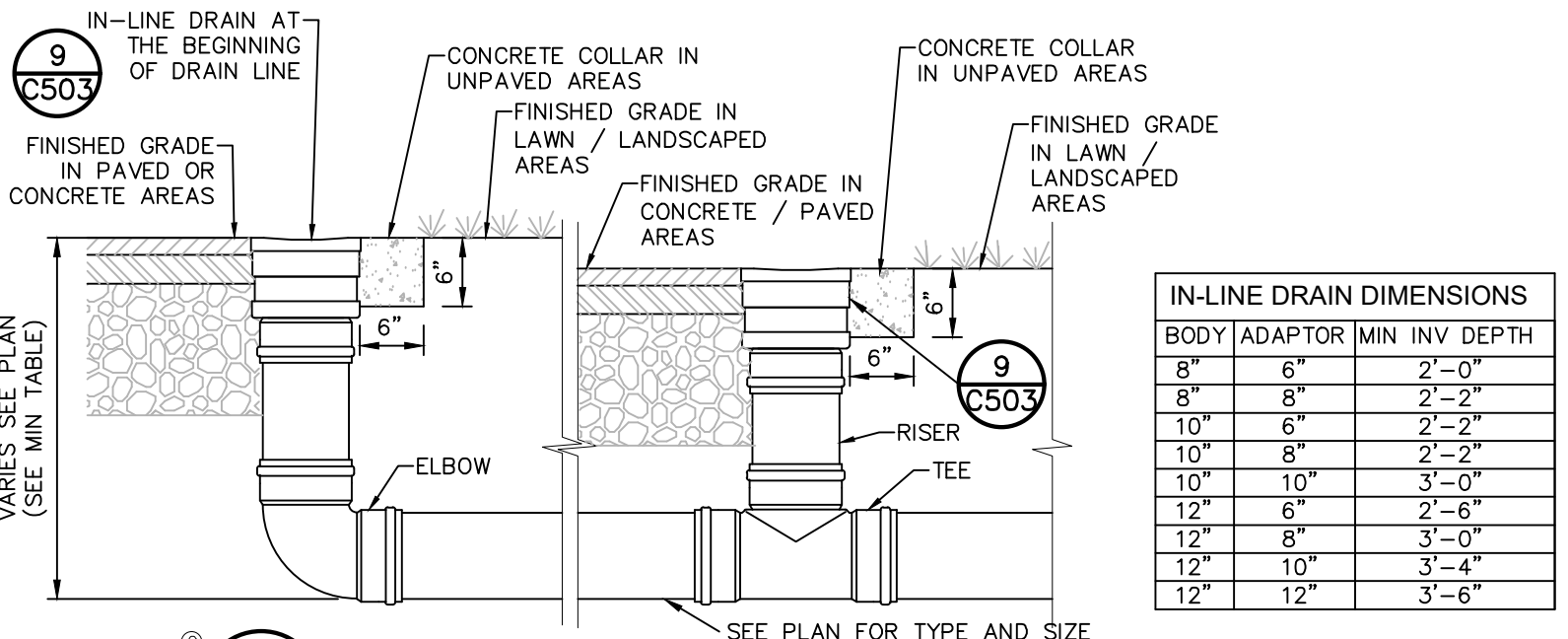

7 YARD IN-LINE DRAIN
SCALE: NOT TO SCALE

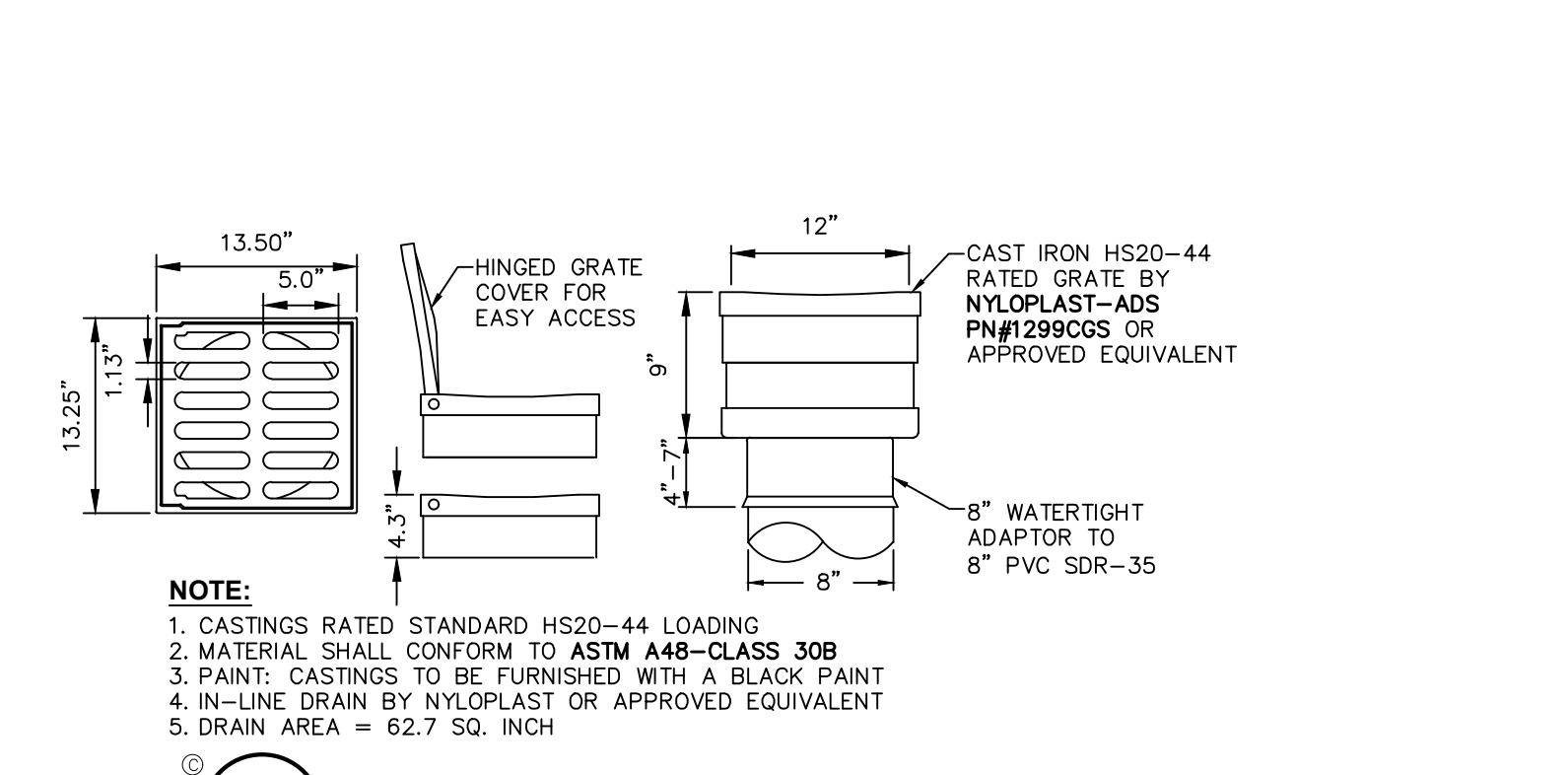

8 12\"/>

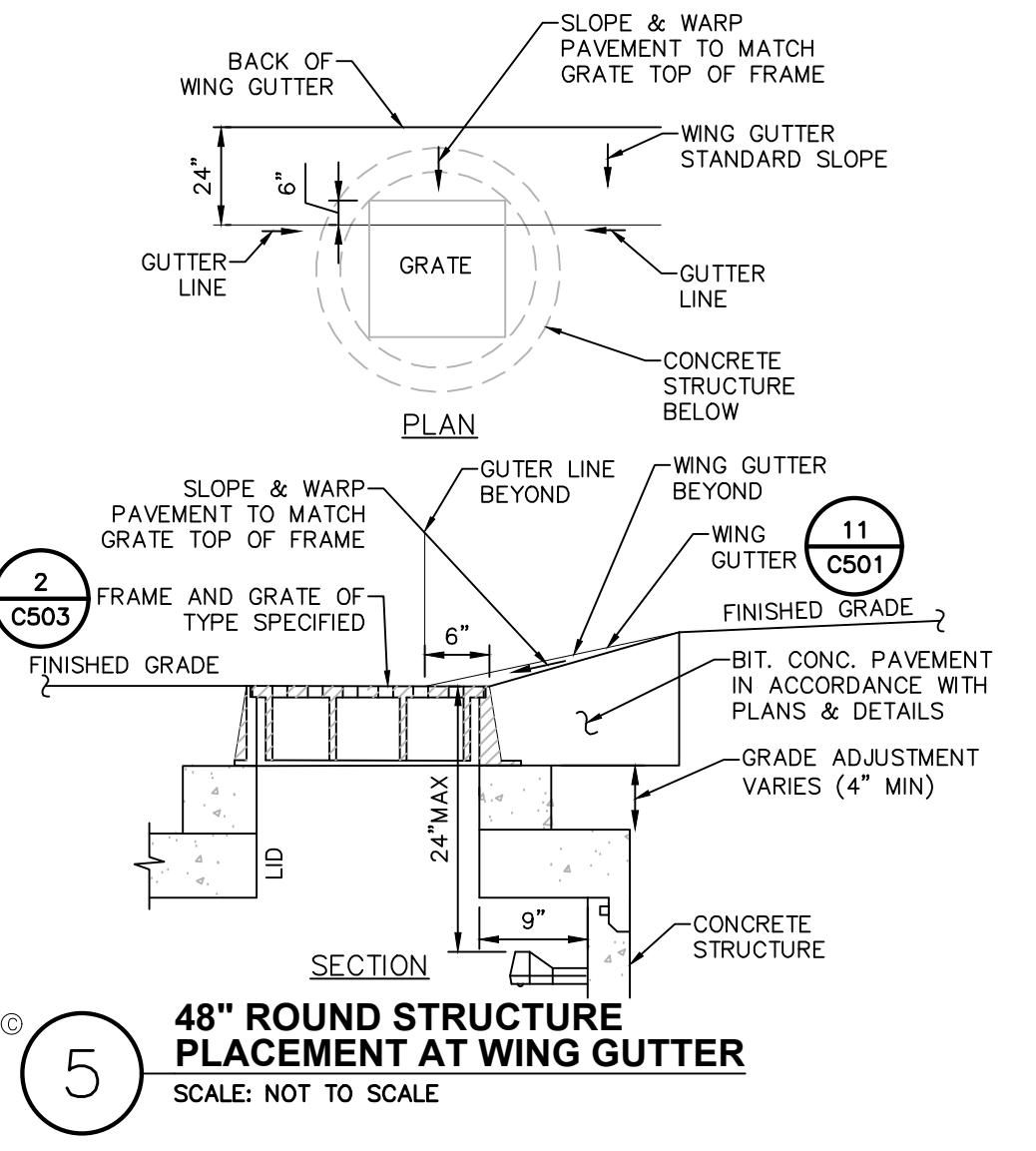

9 48\"/>

STORM SEWER NOTES:

- ALL STORM WATER MANAGEMENT STRUCTURES (I.E. CATCH BASIN, ETC.) SHALL BE REGULARLY INSPECTED FOR SEDIMENT ACCUMULATIONS. CATCH BASINS SHALL BE CLEANED WHEN SEDIMENT DEPTH REACHES A MAXIMUM OF 1/2 THE AVAILABLE SUMP DEPTH.
- IF GROUNDWATER IS ENCOUNTERED DURING CONSTRUCTION ACTIVITIES, THE CONTRACTOR SHALL CONSTRUCT A DEWATERING PIT (A.K.A. SUMP PIT) TO TRAP AND FILTER WATER FOR PUMPING TO A SUITABLE DISCHARGE AREA. THE DEWATERING PIT SHALL BE CONSTRUCTED IN ACCORDANCE WITH THE NEW YORK STATE GUIDELINES FOR URBAN EROSION AND SEDIMENT CONTROL, LATEST EDITION.
- ALL EROSION CONTROL MEASURES EMPLOYED DURING THE CONSTRUCTION PROCESS SHALL BE AS OUTLINED ON THE EROSION AND SEDIMENT CONTROL PLANS, DETAILS AND NOTES.

THE SEVENTY-SIX

Parcel 76, 76 Second Avenue, City of Albany, NY

Owner: South End Development LLC

Architect: Garrison-Architects
45 Main Street
Brooklyn, NY 11201

Civil Engineer: The Chazen Companies
547 River St.
Troy, NY 12180
p (518) 273-0055
Chazen Project No. 32019.00

Revision Schedule

Revision Number	Revision Description	Revision Date

Schematic Design

Scale: AS NOTED
Date: 06/23/2020
Project No: 2005
Drawn by: KC/SM
Checked by: RK

Seal & Signature:

DOB Stamp & Signature

DOB Scan:

Drawing Title:
Storm Sewer Details

Drawing Number:

C-503

DWG.No:

THE SEVENTY-SIX

Parcel 76, 76 Second Avenue, City of Albany, NY

Owner: South End Development LLC

Architect: Garrison-Architects
45 Main Street
Brooklyn, NY 11201

Civil Engineer: The Chazen Companies
547 River St.
Troy, NY 12180
p (518) 273-0055
Chazen Project No. 32019.00

Revision Schedule

Revision Number	Revision Description	Revision Date
-----------------	----------------------	---------------

Schematic Design

Scale: AS NOTED
Date: 06/23/2020
Project No: 2005
Drawn by: KC/SM
Checked by: RK

Seal & Signature:

DOB Stamp & Signature

DOB Scan:

Drawing Title:
Stormwater Management Details

Drawing Number:

C-504

DWG.No:

- A. TREE
(See details for proper planting depth.)
- B. PAVEMENT SURFACE
(Per engineers' specifications. Thicken at treepit opening.)
- C. TREE GRATE & FRAME
(Cast in place frame)
- D. GEOCOMPOSITE/GRID
(Placed horizontally on top of the soil cells. Fold the geocomposite/grid down the outer edge 10" - 12" and fold it out horizontally 10" - 12". Overlap seams 10" - 12")
(GreenBlue Urban - www.greenblue.com)
- E. ROOTSTOP™ 600 ROOT BARRIER
(Wraps vertically around the soil cells. Seams must overlap 10" - 12" and be sealed with seam tape.)
(GreenBlue Urban - www.greenblue.com)
- F. REROOT™ 300 ROOT BARRIER
(Wraps vertically around the inside of the treepit opening with the ribs facing the tree. seams must overlap 10" - 12" and be sealed with seam tape.)
(GreenBlue Urban - www.greenblue.com)
- G. COMPACTED SOIL ROOTBALL PEDESTAL
- H. ROOTRAIN™ CIVIC INLET & PIPE
(Rootball irrigation and aeration system.)
(GreenBlue Urban - www.greenblue.com)
- I. ARBORVENT™ 150 INLET & PIPE
(Soil aeration and irrigation system.)
(GreenBlue Urban - www.greenblue.com)
- J. COMPACTED BACKFILL
Backfill shall be free of organic material, trash and other debris, and shall be free of toxic material injurious to plant growth.
(Compact to 95% minimum standard proctor density)
- K. ROOTSPACE™ 600 PAVEMENT SUPPORT SYSTEM / 1-LAYER
(Filled with planting soil.)
(GreenBlue Urban - www.greenblue.com)
- L. PLANTING SOIL
(Screened sandy loam w/ 4-8% organics by volume. See Planting Soil Specification for composition. Foot compaction only.)
- M. GEOGRID REINFORCEMENT FOR SOIL
(Place on top of aggregate sub-base)
- N. #57 AGGREGATE SUB-BASE / DRAINAGE LAYER - 4" MINIMUM DEPTH
(Compact to 95% minimum standard proctor density)
- O. COMPACTED SUB-BASE
- P. PERFORATED UNDERDRAIN (OPTIONAL)
(Connect to stormwater drainage system per engineers' specifications)

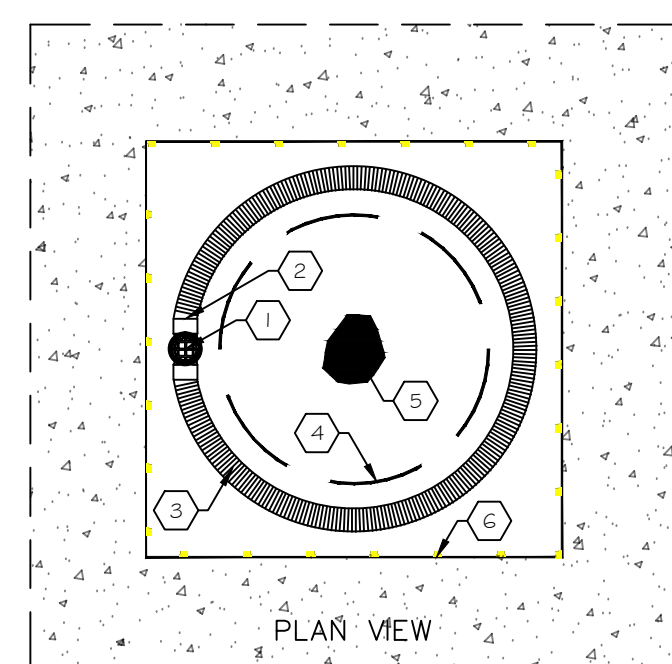
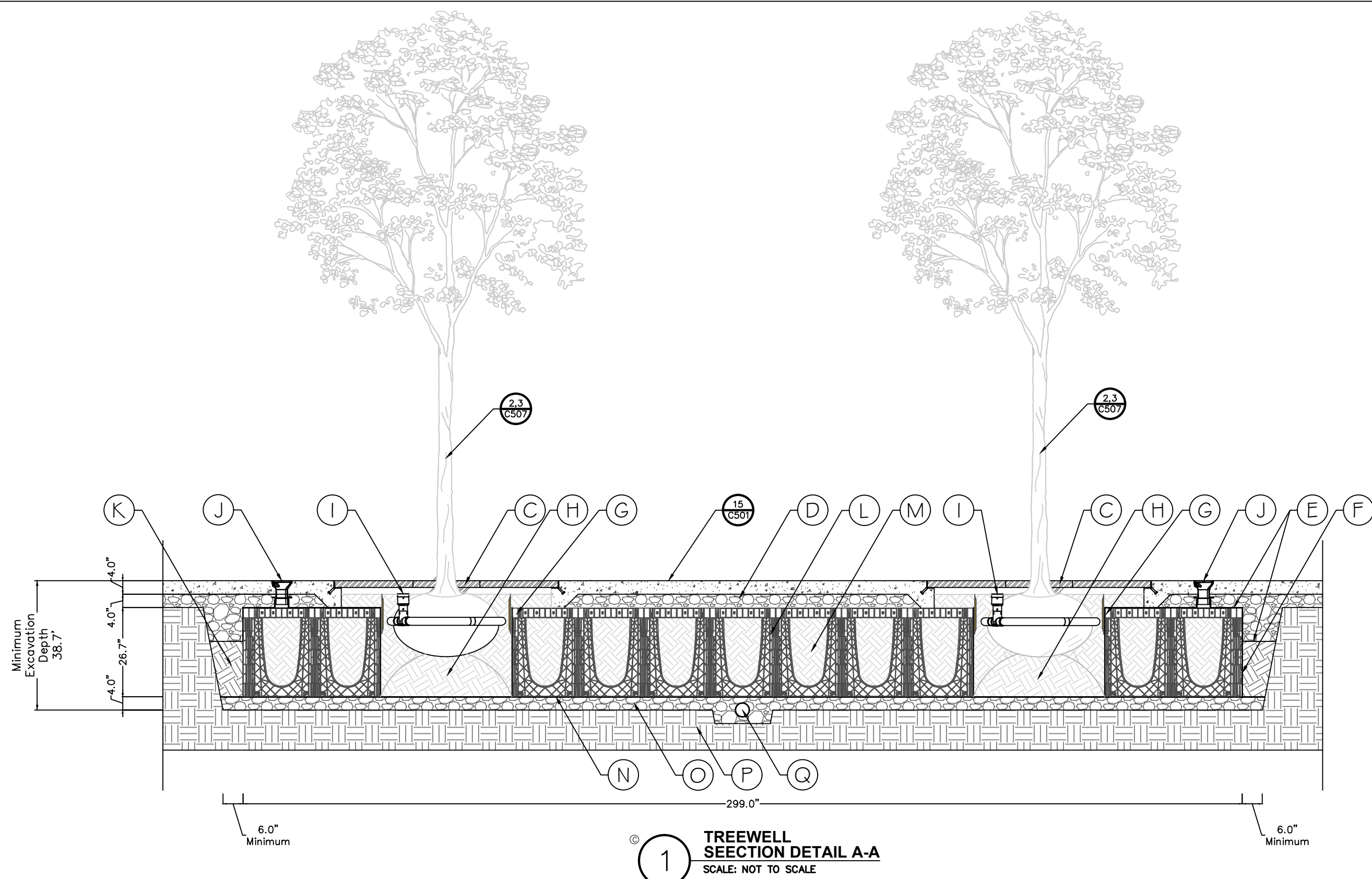

- KEYED NOTES**
1. ROOTRAIN™ AERATION/IRRIGATION SYSTEM INLET.
 2. ROOTRAIN™ AERATION/IRRIGATION SYSTEM TEE.
 3. ROOTRAIN™ AERATION/IRRIGATION SYSTEM PIPE 2 3/8" DIA. FIELD CUT TO FIT AS NEEDED.
 4. TREE TRUNK
 5. TREE TRUNK
 6. REROOT™ URBAN ROOT MANAGEMENT SYSTEM.
- GENERAL NOTES**
- A. ROOTBALL AERATION SYSTEM SHALL BE ROOTRAIN™ AERATION/IRRIGATION SYSTEM AS AVAILABLE FROM GREENBLUE URBAN (866-282-2743).

B ROOTRAIN AERATION SYSTEM
SCALE: NOT TO SCALE

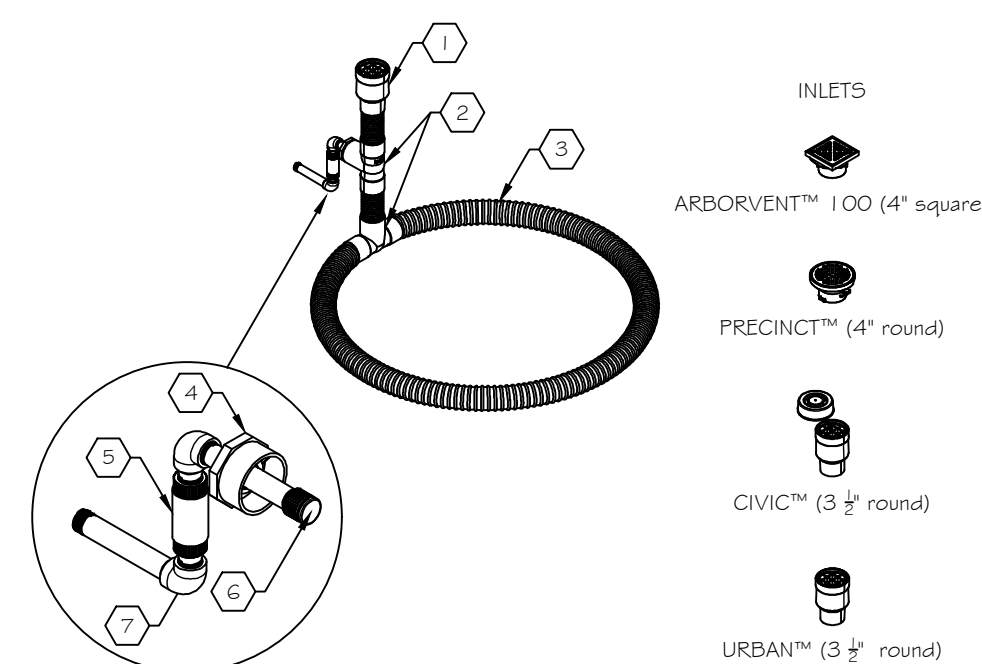

- KEYED NOTES**
1. ROOTRAIN™ AERATION/IRRIGATION SYSTEM INLET, SPECIFY STYLE
 2. ROOTRAIN™ AERATION/IRRIGATION SYSTEM TEE.
 3. ROOTRAIN™ AERATION/IRRIGATION SYSTEM PIPE 2 3/8" DIA. FIELD CUT TO FIT AS NEEDED.
 4. 2" MALE X 1" FEMALE PVC REDUCING BUSHING.
 5. IN-LINE ADJUSTABLE SPRING CHECK VALVE, 1/2" MPT X FIPT PVC, TENSION SPRING. SEE GENERAL NOTE B.
 6. IRRIGATION FLOOD BUBBLER. SEE NOTE C.
 7. PIPE FITTINGS, AS REQUIRED.

- GENERAL NOTES**
- A. ROOTBALL AERATION SYSTEM SHALL BE ROOTRAIN™ AERATION/IRRIGATION SYSTEM AS AVAILABLE FROM GREENBLUE URBAN (866-282-2743).
- B. SPRING CHECK VALVES ARE FACTORY PRESET TO HOLD BACK A MINIMUM OF 5 PSI OF STATIC PRESSURE. CONTRACTOR SHALL ADJUST CHECK VALVES AS REQUIRED TO PREVENT LOW HEAD DRAINAGE.
- C. FLOOD BUBBLER HEAD, 1/2" THREAD, 1 GPM.

B ROOTRAIN AERATION/IRRIGATION SYSTEM
SCALE: NOT TO SCALE

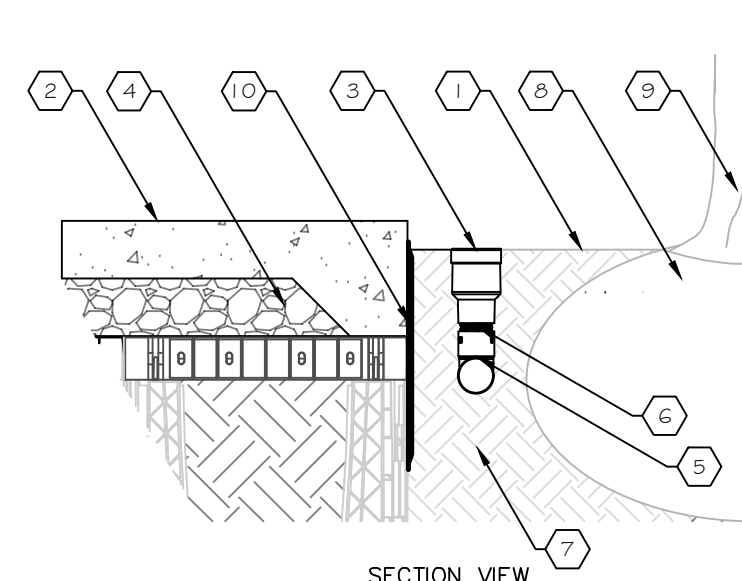

- KEYED NOTES**
1. FINISH GRADE. SEE PLAN
 2. PAVEMENT SURFACE
 3. ROOTRAIN™ AERATION/IRRIGATION SYSTEM INLET.
 4. COMPACTED AGGREGATE PAVEMENT BASE
 5. ROOTRAIN™ AERATION/IRRIGATION SYSTEM TEE.
 6. ROOTRAIN™ AERATION/IRRIGATION SYSTEM PIPE, 2 3/8" DIA. FIELD CUT TO FIT AS NEEDED.
 7. PLANTING SOIL
 8. TREE ROOTBALL
 9. TREE TRUNK
 10. REROOT™ URBAN ROOT MANAGEMENT SYSTEM.

- GENERAL NOTES**
- A. ROOTBALL AERATION SYSTEM SHALL BE ROOTRAIN™ AERATION/IRRIGATION SYSTEM AS AVAILABLE FROM GREENBLUE URBAN (866-282-2743).

A ROOTRAIN AERATION SYSTEM
SCALE: NOT TO SCALE

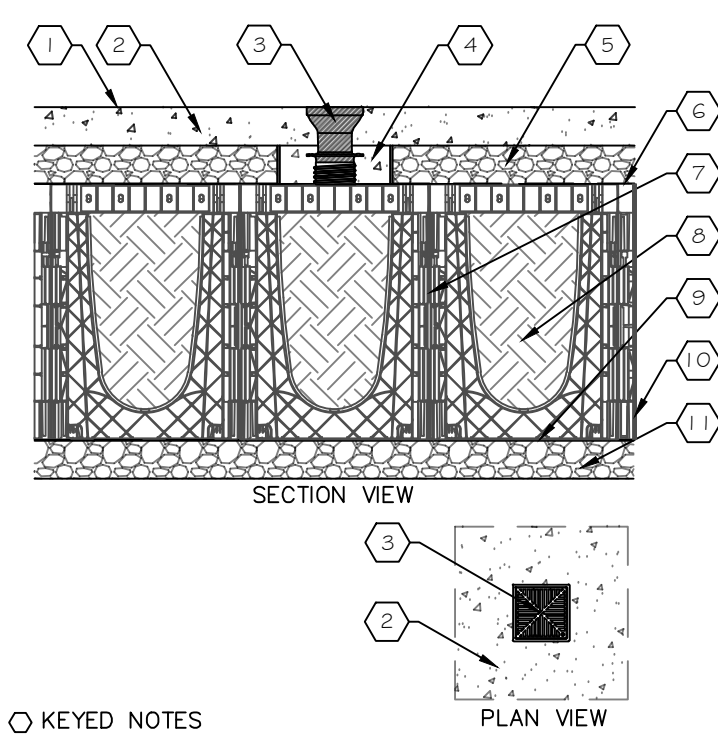

- KEYED NOTES**
1. FINISH GRADE. SEE PLAN
 2. PAVEMENT SURFACE
 3. ARBORVENT™ 150 SOIL AERATION/IRRIGATION SYSTEM INLET. (SEE NOTE A).
 4. CONCRETE COLLAR TO SUPPORT ARBORVENT™ 150 (TYP. 12" DIAMETER).
 5. COMPACTED AGGREGATE PAVEMENT BASE.
 6. GEOGRID/FABRIC COMPOSITE
 7. ROOTSPACE™ PAVEMENT SUPPORT SYSTEM.
 8. PLANTING SOIL
 9. GEOGRID/SOIL REINFORCEMENT
 10. ROOTSTOP™ ROOT AND MOISTURE BARRIER. INSTALL WITHIN 2" OF FINISH GRADE. OVERLAP SEAMS BY 8" AND SEAL WITH FUSION TAPE. MINIMUM 24" DEPTH RECOMMENDED. (SEE NOTE B).
 11. AGGREGATE SUB-BASE

- GENERAL NOTES**
- A. AERATION INLET SHALL BE ARBORVENT™ 150 SOIL AERATION INLET AS AVAILABLE FROM GREENBLUE URBAN (866-282-2743).
- B. ROOT AND MOISTURE BARRIER SHALL BE ROOTSTOP™ (SPECIFY DEPTH) AS AVAILABLE FROM GREENBLUE URBAN (866-282-2743).

J/L ARBORVENT 150 SOIL AERATION INLET
SCALE: NOT TO SCALE

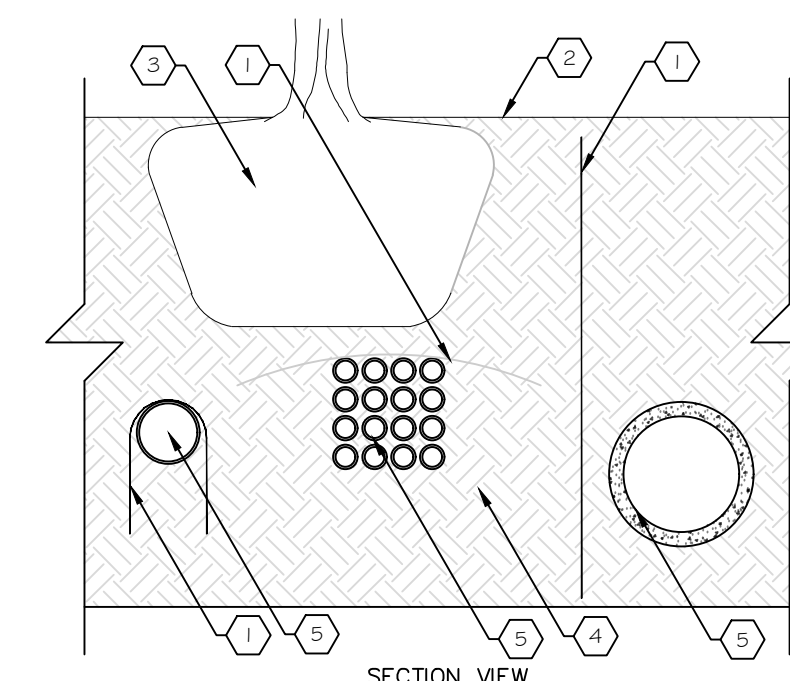

- KEYED NOTES**
1. ROOTSTOP™ ROOT AND MOISTURE BARRIER. INSTALL WITHIN 2" OF FINISH GRADE. OVERLAP SEAMS BY 8" AND SEAL WITH FUSION TAPE. (SEE NOTE A).
 2. FINISH GRADE
 3. TREE ROOTBALL
 4. PLANTING SOIL
 5. UTILITY

- GENERAL NOTES**
- A. ROOT AND MOISTURE BARRIER SHALL BE ROOTSTOP™ (SPECIFY DEPTH) AS AVAILABLE FROM GREENBLUE URBAN (866-282-2743).

I ROOT BARRIER AT UTILITY
SCALE: NOT TO SCALE

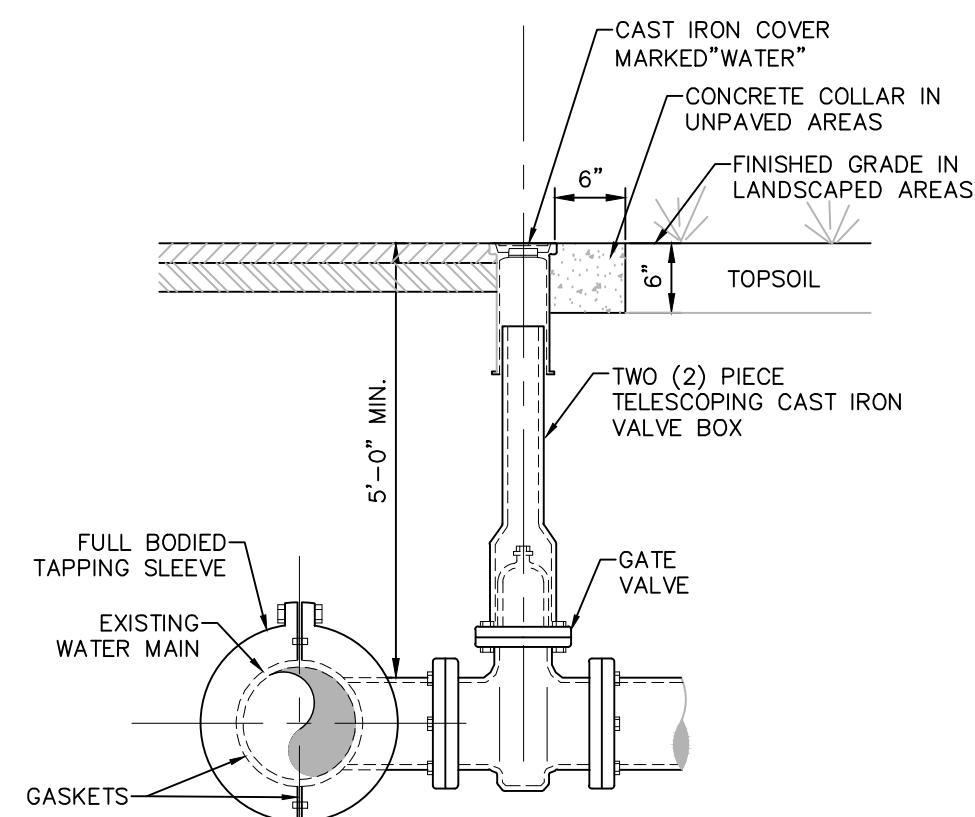

- NOTES:**
1. WET TAP OF PUBLIC WATER MAIN SHALL BE PERFORMED UNDER THE SUPERVISION OF THE ENGINEER, AND THE AUTHORITY HAVING JURISDICTION.
 2. TAPPING SLEEVE AND VALVE SUPPORT SHALL BE COORDINATED WITH THE ENGINEER TO SUIT FIELD CONDITIONS.
 3. MINIMUM DISTANCE TO JOINTS, FITTINGS, OR OTHER WET TAPS OR STOPS SHALL BE 3 FEET.
 4. VALVE OPERATING DIRECTION SHALL BE COUNTERCLOCKWISE TO OPEN (TURNING LEFT).
 5. TAPPING SLEEVE SHALL BE SELECTED TO FIT EXISTING PIPE MATERIAL (C.I., D.I., A.C.) AND OUTSIDE DIAMETERS.
 6. THRUST BLOCK IS REQUIRED WHERE THE BRANCH OF THE TAPPING SLEEVE DOES NOT HAVE RESTRAINED JOINT.
 7. TAPPING SLEEVE, VALVE & VALVE BOX SHALL BE IN ACCORDANCE WITH MUNICIPAL STANDARDS & AS MANUFACTURED BY (MUELLER, CLOW OR WATEROUS) OR APPROVED EQUIVALENT.

1 TAPPING SLEEVE AND VALVE DETAIL
SCALE: NOT TO SCALE

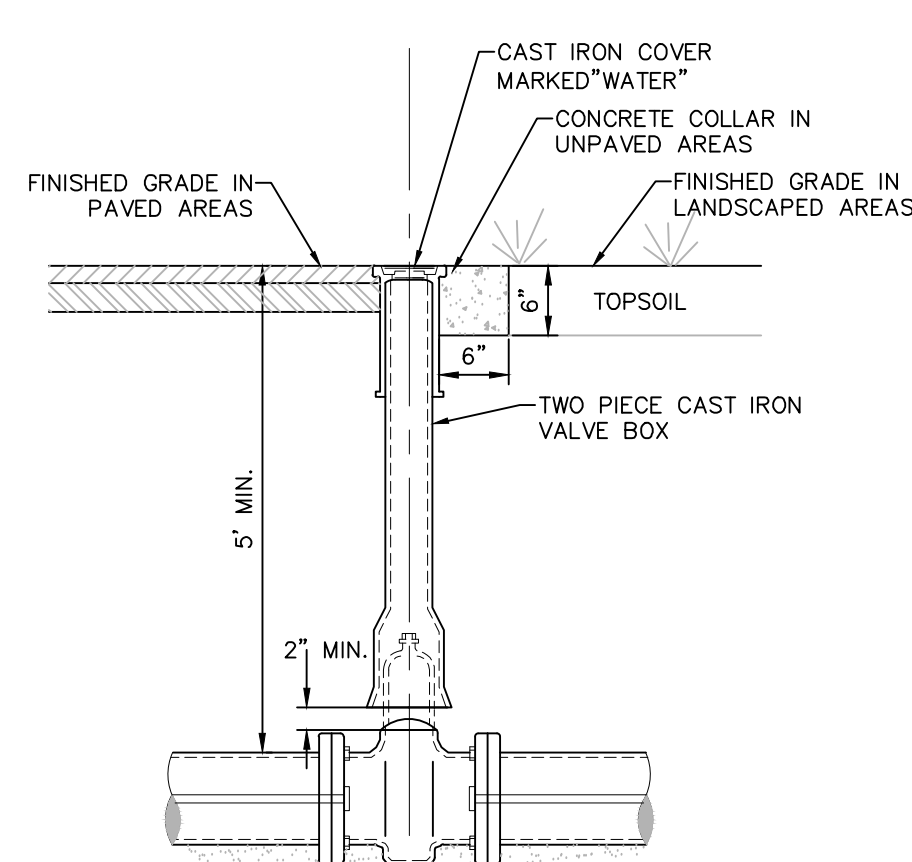

- NOTES:**
1. NON-RISING STEM GATE VALVE, OPERATING DIRECTION SHALL BE COUNTERCLOCKWISE TO OPEN.
 2. MINIMUM DISTANCE TO JOINTS, FITTINGS, OR OTHER WET TAPS OR STOPS SHALL BE 3 FEET.
 3. IF VALVE IS TO BE RODDED, PROVIDE VALVE WITH RODDING FLANGES OR EYEBOLTS. TWO (2) 3/4\"/>

2 TYPICAL GATE VALVE DETAIL
SCALE: NOT TO SCALE

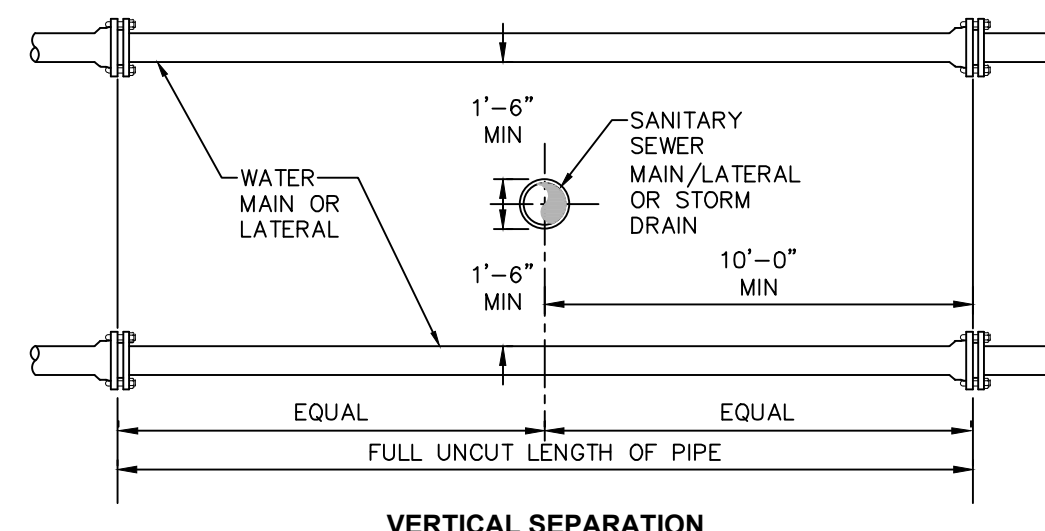

- NOTES:**
1. NO DEVIATION IN THE SEPARATION REQUIREMENTS WILL BE PERMITTED WITHOUT THE EXPRESS APPROVAL OF THE NYS HEALTH DEPARTMENT. OFFSETTING OF WATERLINE SHALL BE REQUIRED WHERE SEPARATION DISTANCES CANNOT BE MAINTAINED.
 2. WHEN IT IS IMPOSSIBLE TO OBTAIN VERTICAL SEPARATION AS INDICATED ABOVE, BOTH THE WATER MAIN AND THE SEWER MAIN SHALL BE CONSTRUCTED OF MECHANICAL JOINT, DUCTILE IRON PIPE OR PVC WATER WORKS GRADE PRESSURE PIPE FOR 10' EACH SIDE OF CROSSING AND SHALL BE PRESSURE TESTED TO 150psi TO ASSURE WATER TIGHTNESS.

3 SANITARY/STORM SEWER AND WATERMAIN SEPARATION DETAIL
SCALE: NOT TO SCALE

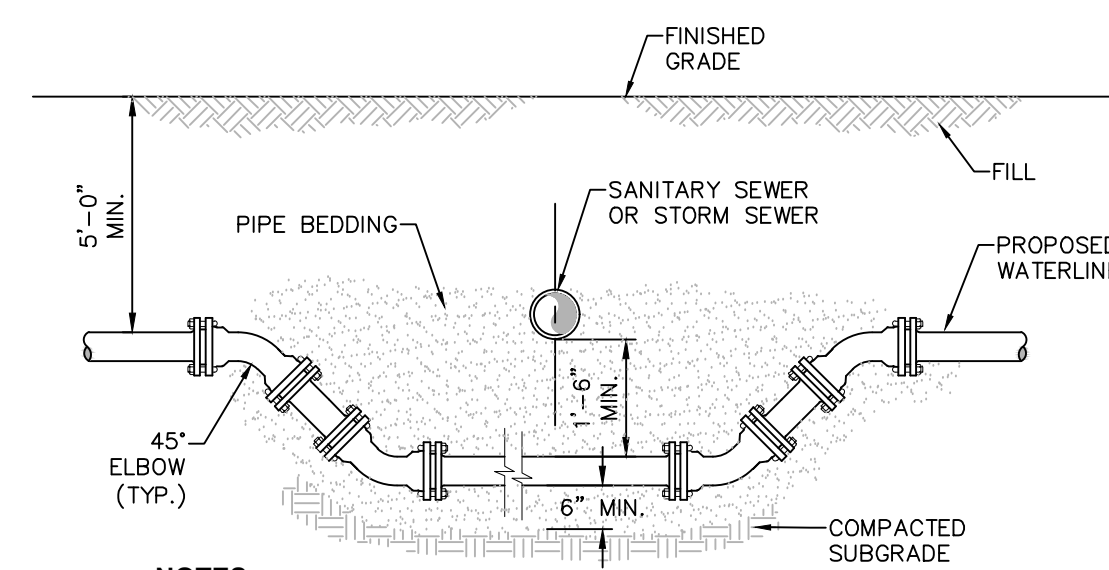

- NOTES:**
1. WHEN THE ELEVATION OF THE SEWER CAN NOT BE VARIED TO MEET THE ABOVE REQUIREMENTS, THE WATER MAIN SHALL BE RELOCATED TO PROVIDE THIS REQUIRED SEPARATION.
 2. WHEN IT IS IMPOSSIBLE TO OBTAIN VERTICAL SEPARATION AS INDICATED ABOVE, BOTH THE WATER MAIN AND THE SEWER MAIN SHALL BE CONSTRUCTED OF MECHANICAL JOINT DUCTILE IRON PIPE OR PVC WATER WORKS GRADE PRESSURE PIPE FOR 10' EACH SIDE OF CROSSING AND SHALL BE PRESSURE TESTED TO 150psi TO ASSURE WATER TIGHTNESS.

4 WATERLINE OFFSET DETAIL
SCALE: NOT TO SCALE

SCHEDULE OF JOINT RESTRAINT— (PVC OR POLYWRAPPED DIP)
(LENGTH OF PIPE EACH SIDE OF FITTING TO BE RESTRAINED IN FEET "L")

PIPE SIZE (INCHES)	FITTING TYPE														
	90°	45°	22 1/2°	TEE	VALVE DEAD END	24"	18"	16"	14"	12"	10"	8"	6"	4"	
30"	241	103	48	24	202	208	208	72	130	145	159				
24"	198	82	39	20	163	166	166	72	91	108	123	136			
18"	149	62	30	15	122	125	125	26	49	68	85	99			
16"	134	56	27	14	109	112	112	26	48	67	82	95			
14"	118	49	24	12	95	98	98	26	47	64	79	89			
12"	102	43	21	11	82	85	85			25	45	62	74		
10"	86	36	17	9	68	71	71				25	44	56		
8"	71	30	15	7	56	59	59					25	43		
6"	54	22	11	6	41	44	44						23		
4"	38	16	8	4	28	31	31								

- NOTES:**
1. THE LENGTH OF PIPE REQUIRING RESTRAINT IS BASED UPON THE FOLLOWING ASSUMPTIONS:
 - A. BEDDING TYPE 2 - FLAT BOTTOM TRENCH, BACKFILL LIGHTLY CONSOLIDATED TO CENTER LINE OF PIPE.
 - B. SOIL TYPE CLAY 1 - CLAY OF MEDIUM TO LOW PLASTICITY, LL<50, <25% COURSE PARTICLES [CL & CL-ML] ; CL - INORGANIC CLAYS OF LOW TO MEDIUM PLASTICITY GRAVELLY CLAYS, SANDY CLAYS, SILTY CLAYS; LEAN CLAYS ML - INORGANIC SILTS, VERY FINE SAND, ROCK FLOUR, SILTY OR CLAYEY FINE SANDS.
 2. PIPE TABLE CALCULATION IS BASED ON PVC OR POLYWRAPPED DIP.
 3. DEPTH TO TOP OF PIPE 5'-0" MINIMUM.
 4. MAXIMUM OPERATING PRESSURE OF 150 PSI.
 5. FACTOR OF SAFETY OF 1.5.
 6. FOR END PLUGS, USE RESTRAIN PIPE LENGTH GIVEN FOR DEAD END FITTING.
 7. THE LENGTH ("L") OF NEW PIPE TO BE RESTRAINED IS THE LENGTH FOR EACH SIDE OF THE FITTING.
 8. THE ABOVE INFORMATION WAS PROVIDED USING THE THRUST RESTRAINT PROGRAM ISSUED BY THE DUCTILE IRON PIPE RESEARCH ASSOCIATION (DIPRA) AND IS BASED ON THE ASSUMPTIONS LISTED IN NOTE 1. RESTRAINED LENGTH REQUIREMENTS FOR FIELD CONDITIONS AND PIPE SIZES DIFFERING FROM THOSE LISTED ABOVE SHOULD BE EVALUATED SEPARATELY.
 9. RESTRAINED JOINT PIPE AND FITTINGS SHALL BE USED ONLY AS ALLOWED BY THE PROJECT PLANS AND/OR SPECIFICATION. (IF THRUST BLOCKS ARE USED SEE THRUST BLOCK DETAIL.)
 10. TEE FITTINGS: PIPE SIZE SHOWN FOR THE TEE IS THE SIZE OF THE RUN. THE RESTRAINED LENGTH SHOWN IS FOR THE BRANCH. THE VALUE OF THE RESTRAINED LENGTH ASSUMES THAT THE SIZE OF THE BRANCH IS EQUAL TO OR LESS THAN THE RUN. THE VALUE OF THE L=USED IN THE TABLE IS 10 FEET. (L= TOTAL LENGTH BETWEEN FIRST JOINTS ON EITHER SIDE OF THE TEE ON THE RUN.)

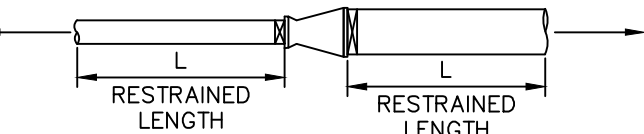

REDUCERS
ALL JOINTS WITHIN LENGTH "L" SHALL BE RESTRAINED

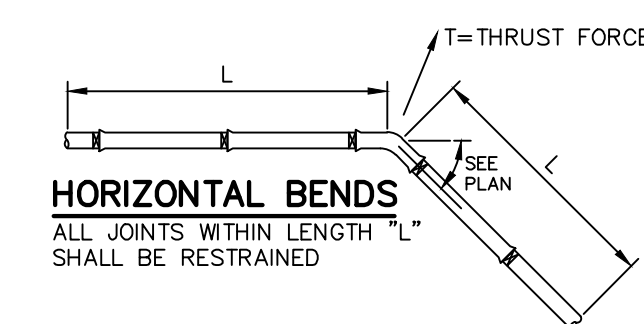

HORIZONTAL BENDS
ALL JOINTS WITHIN LENGTH "L" SHALL BE RESTRAINED

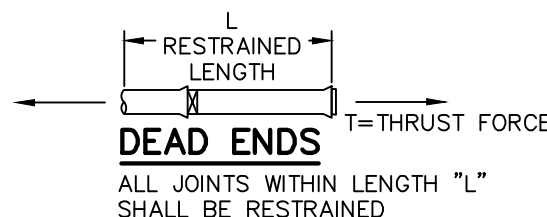

DEAD ENDS
ALL JOINTS WITHIN LENGTH "L" SHALL BE RESTRAINED

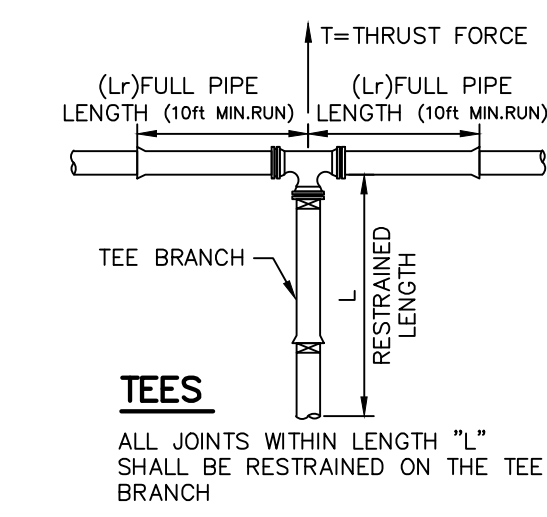

TEES
ALL JOINTS WITHIN LENGTH "L" SHALL BE RESTRAINED ON THE TEE BRANCH

6 RESTRAINED JOINT PIPE DIAGRAMS
SCALE: NOT TO SCALE

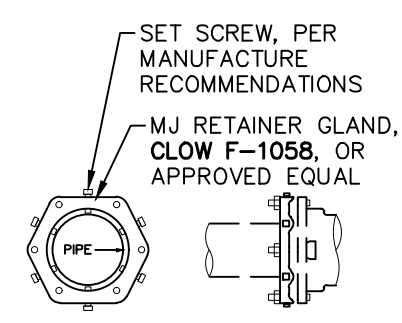

7 RESTRAINED JOINT THRUST RESTRAINT DETAIL
SCALE: NOT TO SCALE

5 JOINT RESTRAINT SCHEDULE AND NOTES
SCALE: NOT TO SCALE

TESTING WATER MAINS:

1. THE CONTRACTOR SHALL SUBMIT A TESTING PLAN FOR FLUSHING, PRESSURE TESTING, LEAKAGE TESTING AND DISINFECTION OF WATER MAINS TO BE APPROVED BY THE ENGINEER PRIOR TO COMMENCING PIPING INSTALLATION.
2. AFTER TRENCH HAS BEEN BACKFILLED, HYDROSTATIC ACCEPTANCE TESTS, CONSISTING OF A PRESSURE TEST AND A LEAKAGE TEST, SHALL BE PERFORMED ON ALL SECTIONS OF WATER MAINS INSTALLED. LEAKAGE TEST SHALL BE CONDUCTED CONCURRENTLY WITH PRESSURE TEST. TEST SECTION SHALL BE LIMITED TO ABOUT 2,000 FT (MAX.) OR FOR EACH DIFFERENT PIPE MATERIAL SEGMENT, UNLESS OTHERWISE APPROVED BY THE ENGINEER.
3. AFTER ALL TESTS AND INSPECTIONS HAVE BEEN PERFORMED EVIDENCE OF COMPLIANCE SHALL BE FORWARDED TO OWNER/ENGINEER AND THE MUNICIPALITY PRIOR TO ACCEPTANCE.
4. ALL WATER FOR TESTS SHALL BE FURNISHED AND DISPOSED OF BY THE CONTRACTOR AT THE CONTRACTOR'S EXPENSE. SOURCE AND/OR QUALITY OF WATER WHICH THE CONTRACTOR PROPOSES TO USE IN TESTING LINES SHALL BE ACCEPTABLE TO THE ENGINEER.
5. HYDROSTATIC PRESUMPTIVE TESTS MAY BE PERFORMED WHEN SYSTEM IS PARTIALLY BACKFILLED TO SIMPLY CHECK WORK, BUT ACCEPTANCE OF SYSTEM SHALL BE BASED ON HYDROSTATIC TESTS RUN ON FINISHED SYSTEM AFTER IT HAS BEEN COMPLETELY BACKFILLED.
6. HYDROSTATIC TESTS SHALL BE PERFORMED IN ACCORDANCE WITH THE FOLLOWING, AS MODIFIED HEREIN:
 - 6.1. SECTION 5 OF AWWA STANDARD C600, LATEST ADDITION, FOR DUCTILE-IRON MAINS.
 - 6.2. SECTION 7 OF AWWA STANDARD C605, LATEST ADDITION, FOR PVC MAINS.
 - 6.3. CHAPTER 9 OF AWWA STANDARD M55, LATEST ADDITION, FOR HDPE MAINS.
7. FOR PRESSURE TESTING OF DUCTILE-IRON MAINS, THE SYSTEM SHALL BE PRESSURIZED AND MAINTAINED AT A MINIMUM OF 1.25 TIMES THE MAXIMUM ANTICIPATED SUSTAINED WORKING PRESSURE, WHICHEVER IS GREATER, BASED ON THE ELEVATION OF THE LOWEST POINT IN THE SECTION BEING TESTED AND CORRECTED TO THE ELEVATION OF THE GAUGE. PROVISIONS SHALL BE MADE TO RELIEVE AIR TRAPPED AT HIGH POINTS IN THE SYSTEM THROUGH ADJACENT HYDRANTS OR THROUGH TAPS AND CORPORATION STOPS INSTALLED FOR THIS PURPOSE BY THE CONTRACTOR. AFTER SAID PRESSURE HAS BEEN MAINTAINED SUCCESSFULLY, WITH FURTHER PUMPING AS REQUIRED, FOR A PERIOD OF AT LEAST TWO HOURS, THE SECTION UNDER TEST SHALL BE CONSIDERED TO HAVE PASSED THE PRESSURE TEST.
8. FOR PRESSURE TESTING OF PVC MAINS, THE SYSTEM SHALL BE PRESSURIZED AND MAINTAINED AT A MINIMUM OF 1.25 TIMES THE MAXIMUM ANTICIPATED SUSTAINED WORKING PRESSURE AT THE HIGHEST POINT ALONG THE TEST SECTION UNLESS THE PRESSURE EXCEEDS THE DESIGN PRESSURE LIMIT FOR ANY PIPE, THRUST RESTRAINT, VALVE FITTING, OR OTHER APPURTENANCE OF THE TEST SECTION & NOT LESS THAN 1.5 TIMES THE STATED SUSTAINED WORKING PRESSURE AT THE LOWEST ELEVATION OF THE TEST SECTION. PROVISIONS SHALL BE MADE TO RELIEVE AIR TRAPPED AT HIGH POINTS IN THE SYSTEM THROUGH ADJACENT HYDRANTS OR THROUGH TAPS AND CORPORATION STOPS INSTALLED FOR THIS PURPOSE BY THE CONTRACTOR. AFTER SAID PRESSURE HAS BEEN MAINTAINED SUCCESSFULLY, WITH FURTHER PUMPING AS REQUIRED, FOR A PERIOD OF AT LEAST TWO HOURS, THE SECTION UNDER TEST SHALL BE CONSIDERED TO HAVE PASSED THE PRESSURE TEST.
9. FOR PRESSURE TESTING OF HDPE MAINS, THE SYSTEM SHALL BE PRESSURIZED AND MAINTAINED AT 1.5 TIMES THE DESIGN WORKING PRESSURE AT THE ELEVATION OF THE LOWEST POINT IN THE SECTION BEING TESTED AND CORRECTED TO THE ELEVATION OF THE GAUGE. PROVISIONS SHALL BE MADE TO RELIEVE AIR TRAPPED AT HIGH POINTS IN THE SYSTEM THROUGH ADJACENT HYDRANTS OR THROUGH TAPS AND CORPORATION STOPS INSTALLED FOR THIS PURPOSE BY THE CONTRACTOR. AFTER SAID PRESSURE HAS BEEN MAINTAINED SUCCESSFULLY, WITH FURTHER PUMPING AS REQUIRED, FOR A PERIOD OF AT LEAST FOUR HOURS, THE SECTION UNDER TEST SHALL BE CONSIDERED TO HAVE PASSED THE PRESSURE TEST. FAILING TEST SECTION MUST BE DEPRESSURIZED AND ALLOWED TO "RELAX" FOR AT LEAST EIGHT HOURS PRIOR TO RETESTING.
10. LEAKAGE TEST SHALL BE PERFORMED CONCURRENTLY USING A MINIMUM TEST PRESSURE OF 150 LBS/SQUARE INCH, OR 1.5 TIMES THE WORKING PRESSURE, WHICHEVER IS GREATER, BASED ON THE ELEVATION OF THE LOWEST POINT IN THE SECTION UNDER TEST AND CORRECTED TO ELEVATION OF THE GAUGE. LEAKAGE TEST DURATION SHALL BE A MINIMUM OF 2 HOURS AFTER LEAKAGE RATE HAS STABILIZED.
11. MAXIMUM ALLOWABLE LEAKAGE SHALL BE AS SHOWN IN THE FOLLOWING TABLE:
ALLOWABLE LEAKAGE PER 1,000 FT (305M) OF PIPELINE (GPH)

AVG. TEST PRESSURE (PSI)	NOMINAL PIPE DIAMETER-IN.						
	4	6	8	10	12	14	16
450	0.57	0.86	1.15	1.43	1.72	2.01	2.29
400	0.54	0.81	1.08	1.35	1.62	1.89	2.16
350	0.51	0.76	1.01	1.26	1.52	1.77	2.02
300	0.47	0.70	0.94	1.17	1.40	1.64	1.87
275	0.45	0.67	0.90	1.12	1.34	1.57	1.79
250	0.43	0.64	0.85	1.07	1.28	1.50	1.71
225	0.41	0.61	0.81	1.01	1.22	1.42	1.62
200	0.38	0.57	0.76	0.96	1.15	1.34	1.53
175	0.36	0.54	0.72	0.89	1.07	1.25	1.43
150	0.33	0.50	0.66	0.83	0.99	1.16	1.32
125	0.30	0.45	0.60	0.76	0.91	1.06	1.21
100	0.27	0.41	0.54	0.68	0.81	0.95	1.08

12. IF LEAKAGE IN SYSTEM EXCEEDS THE SPECIFIED AMOUNT, THE CONTRACTOR SHALL, AT NO ADDED COST TO THE OWNER, LOCATE, REPAIR, AND/OR REPLACE DEFECT(S) AND RE-TEST PIPING SYSTEM.

THE SEVENTY-SIX

Parcel 76, 76 Second Avenue, City of Albany, NY

Owner: South End Development LLC

Architect: The Chazen Architects
45 Main Street
Brooklyn, NY 11201

Civil Engineer: The Chazen Companies
547 River St.
Troy, NY 12180
p (518) 273-0055
Chazen Project No. 32019.00

Revision Schedule

Revision Number	Revision Description	Revision Date
-----------------	----------------------	---------------

Schematic Design

Scale: AS NOTED
Date: 06/23/2020
Project No: 2005
Drawn by: KC/SM
Checked by: RK

Seal & Signature:

DOB Stamp & Signature

DOB Scan:

Drawing Title:

Water System Details

Drawing Number:

C-505

DWG.No:

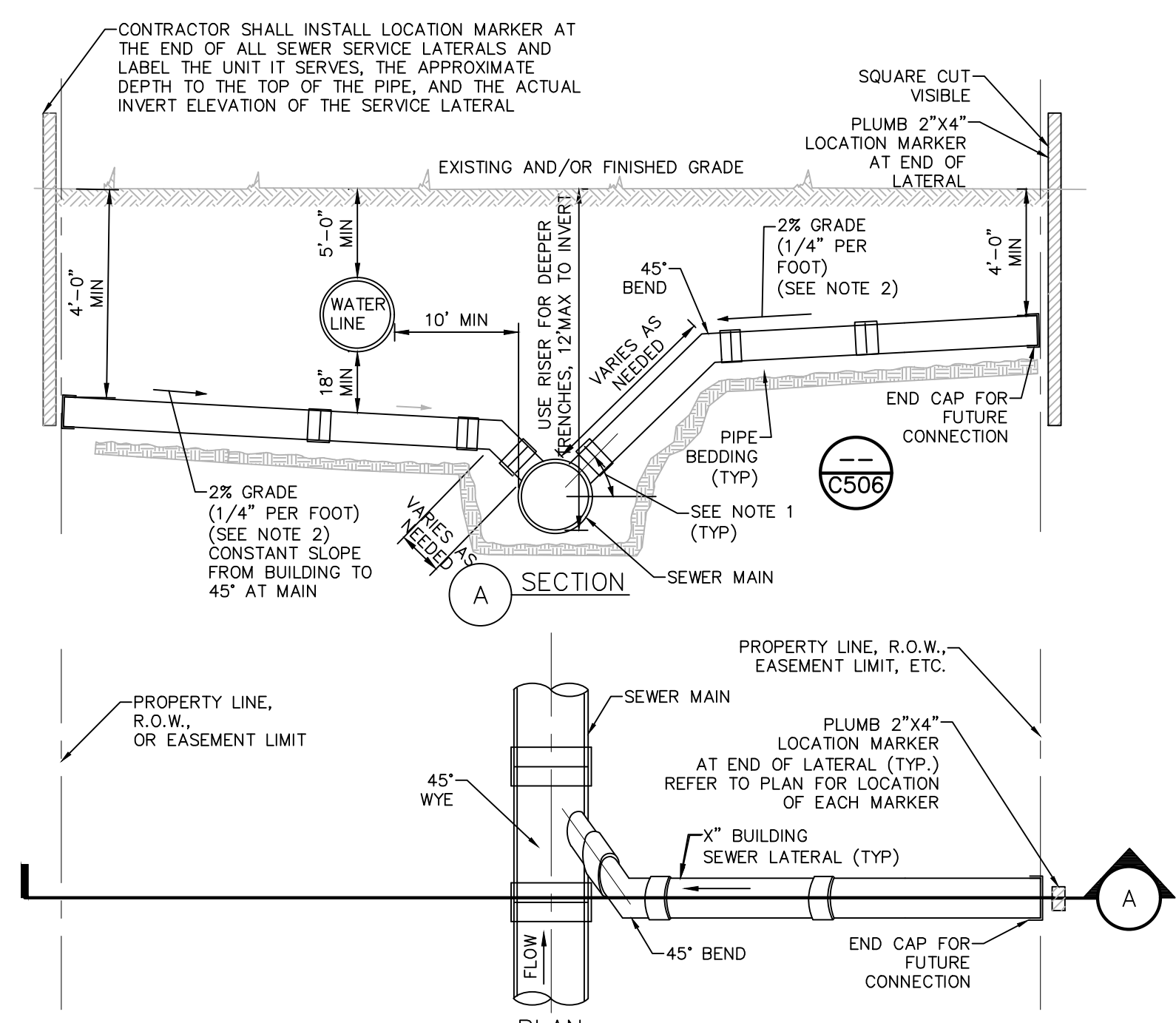

NOTES:
 1. OPTIMUM ANGLE IS 45°. THE ENGINEER MAY CALL FOR OTHER ANGLES TO SUIT JOB CONDITIONS.
 2. THE CONTRACTOR SHALL BE RESPONSIBLE FOR INSTALLING THE SEWER LATERAL AS CONFIGURED AT THE SLOPE SPECIFIED, AND FOR ESTABLISHING THE ELEVATION AT THE TERMINATION POINT OF THE LATERAL, IF EXISTING UTILITIES OR OTHER FEATURES PREVENT INSTALLATION IN THAT MANNER. THE ENGINEER SHALL BE CONSULTED PRIOR TO INSTALLATION.

1 STANDARD SEWER SERVICE CONNECTION PLAN
 SCALE: NOT TO SCALE

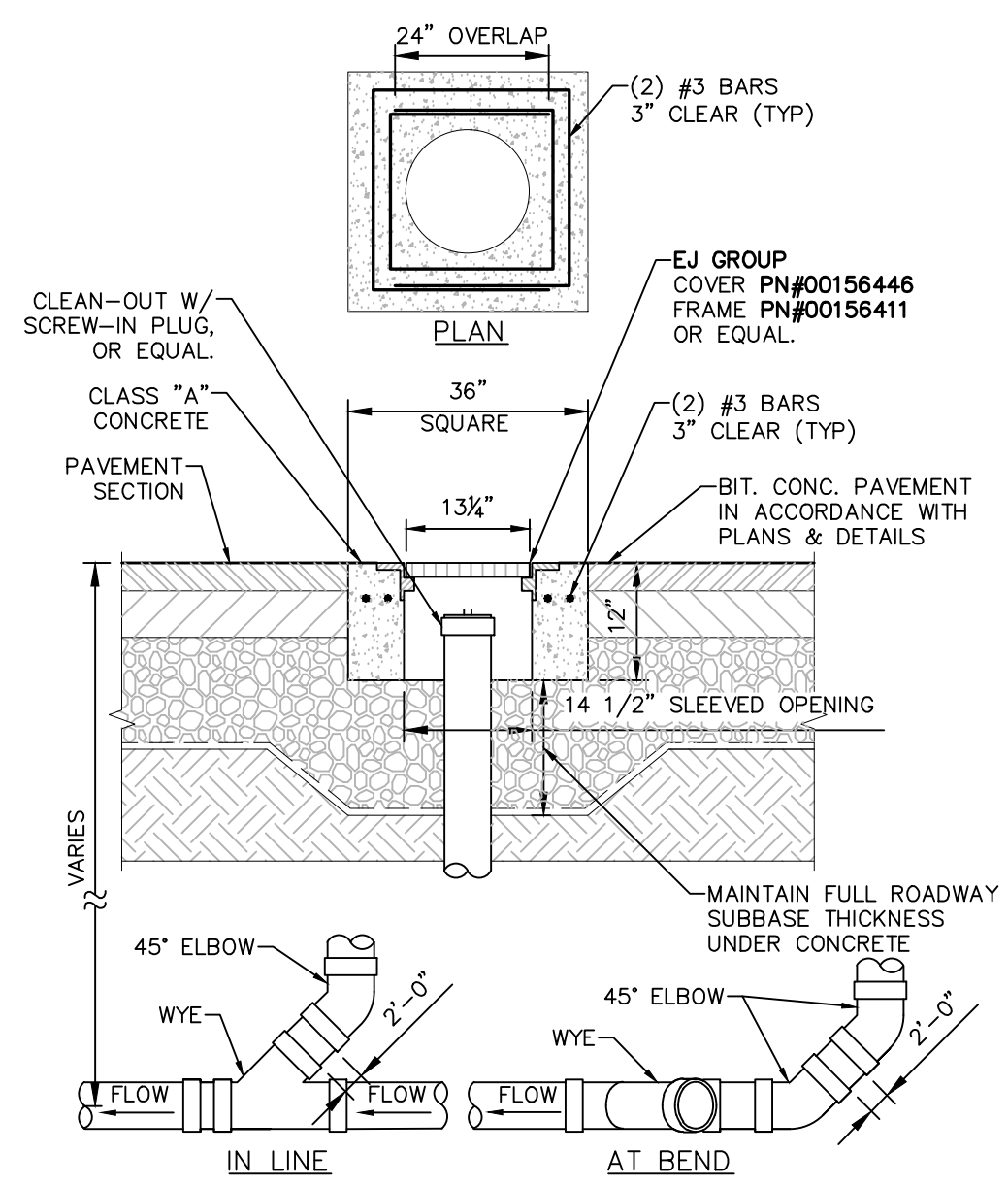

NOTES:
 1. SEWER PIPE FITTINGS TO BE ASTM D-3033 OR D-3034 SDR-35 PVC.
 2. TO BE USED FOR GRAVITY PORTION OF SANITARY SYSTEM AS WELL AS THE STORM ROOF DRAINAGE SYSTEM.

2 CLEAN OUT - TRAFFIC AREAS
 SCALE: NOT TO SCALE

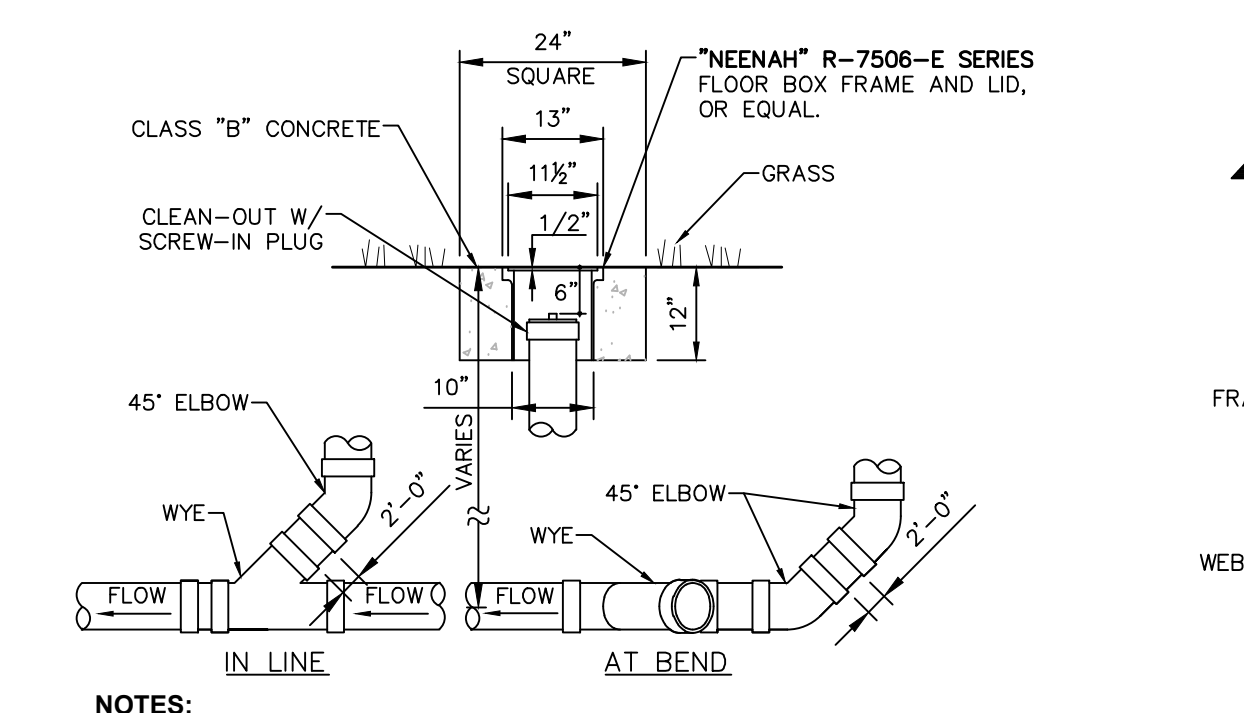

NOTES:
 1. SEWER PIPE FITTINGS TO BE ASTM D-3033 OR D-3034 SDR-35.
 2. TO BE USED FOR GRAVITY PORTION OF SANITARY SYSTEM AS WELL AS THE STORM ROOF DRAINAGE SYSTEM.

3 CLEAN OUT - NON TRAFFIC AREAS
 SCALE: NOT TO SCALE

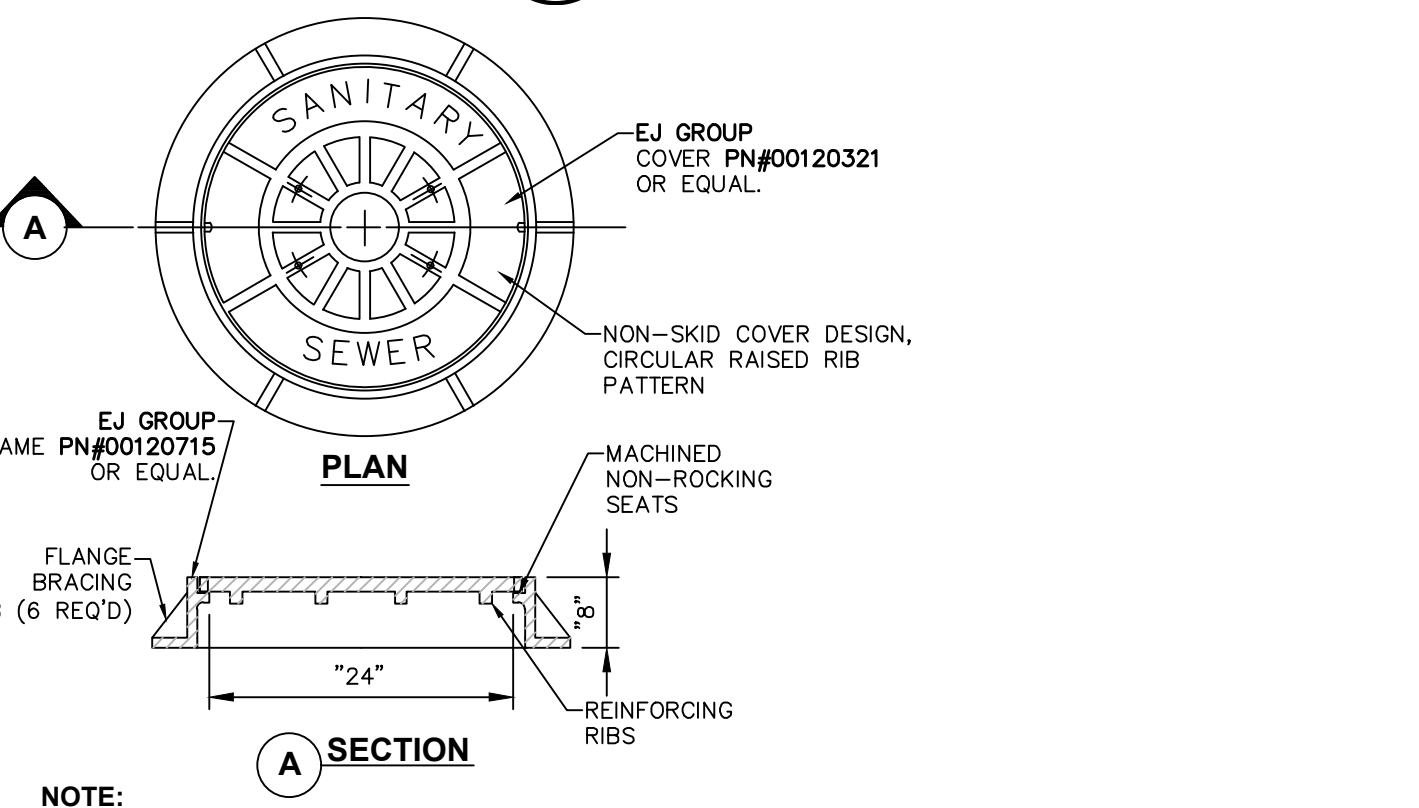

NOTE:
 1. FRAME AND COVER SHALL BE DESIGNED FOR HS20-44 VEHICLE LOADING AND 25% IMPACT.

4 HEAVY DUTY STANDARD CAST IRON MH COVER
 SCALE: NOT TO SCALE

ACCEPTABLE MANHOLE STEPS

MANUFACTURER	PATTERN NUMBER	"A" STEP WIDTH	"B" LEG LENGTH	"C" RUNG CLEAR	"D" EMBED-MENT	"E" RUNG CLEAR
M.A. INDUSTRIES INC.	PS2-PF	14 3/4	9 1/4	13 3/4	3 3/8	5 7/8
M.A. INDUSTRIES INC.	PS2-PFS	14 3/4	8 1/4	13 3/4	3 3/8	4 7/8

* OR EQUIVALENT
 MH STEP DESIGN AND INSTALLATION SHALL COMPLY WITH ALL OSHA REGULATIONS

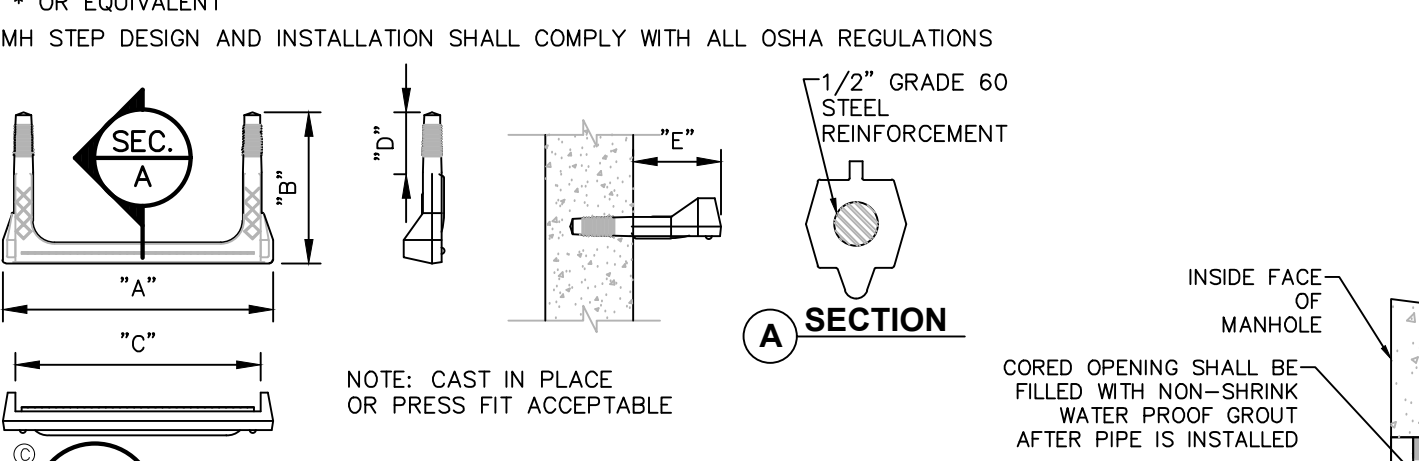

NOTES:
 1. USE ONLY WET-CAST UNITS. DRY-CAST NOT ACCEPTABLE.

5 PRECAST CONCRETE MANHOLE
 SCALE: NOT TO SCALE

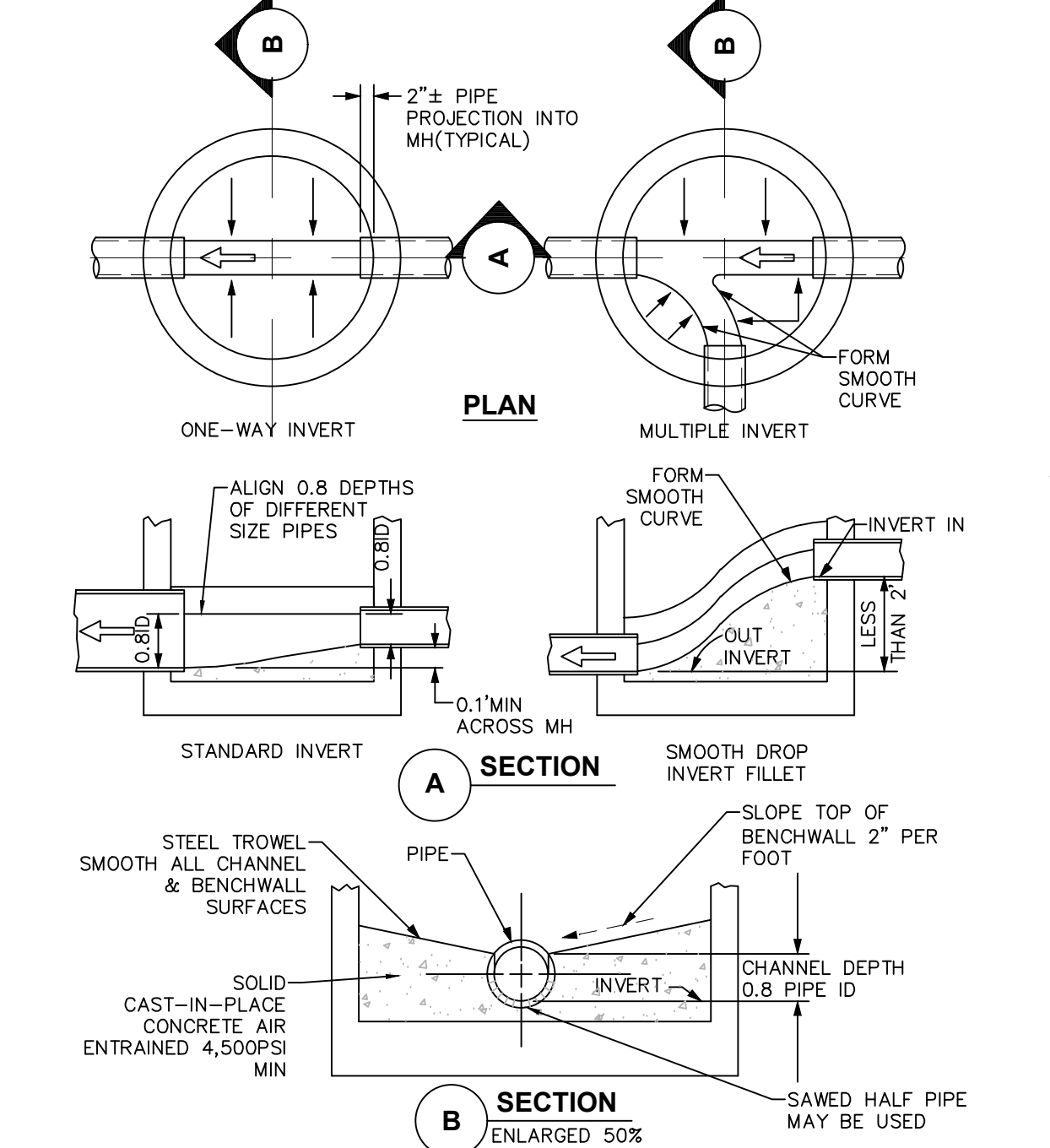

NOTE:
 INLET AND OUTLET OF PIPES SHOWN ON PLAN VIEW OF BASE ARE NOT NECESSARILY TYPICAL OF ALL MANHOLES. REFER TO UTILITY PLAN FOR INLET AND OUTLET DIRECTIONS.

6 INVERT, CHANNEL AND BENCHWALLS
 SCALE: NOT TO SCALE

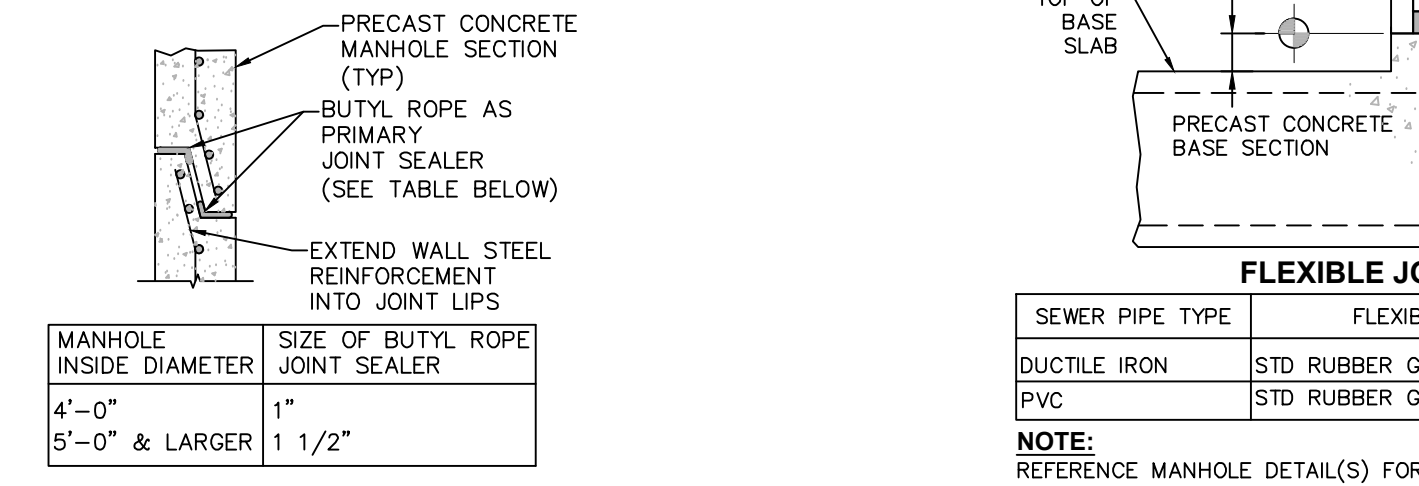

NOTE:
 1. MANHOLE INSIDE DIAMETER
 2. SIZE OF BUTYL ROPE JOINT SEALER

7 COPOLYMER POLYPROPYLENE MH STEP
 SCALE: NOT TO SCALE

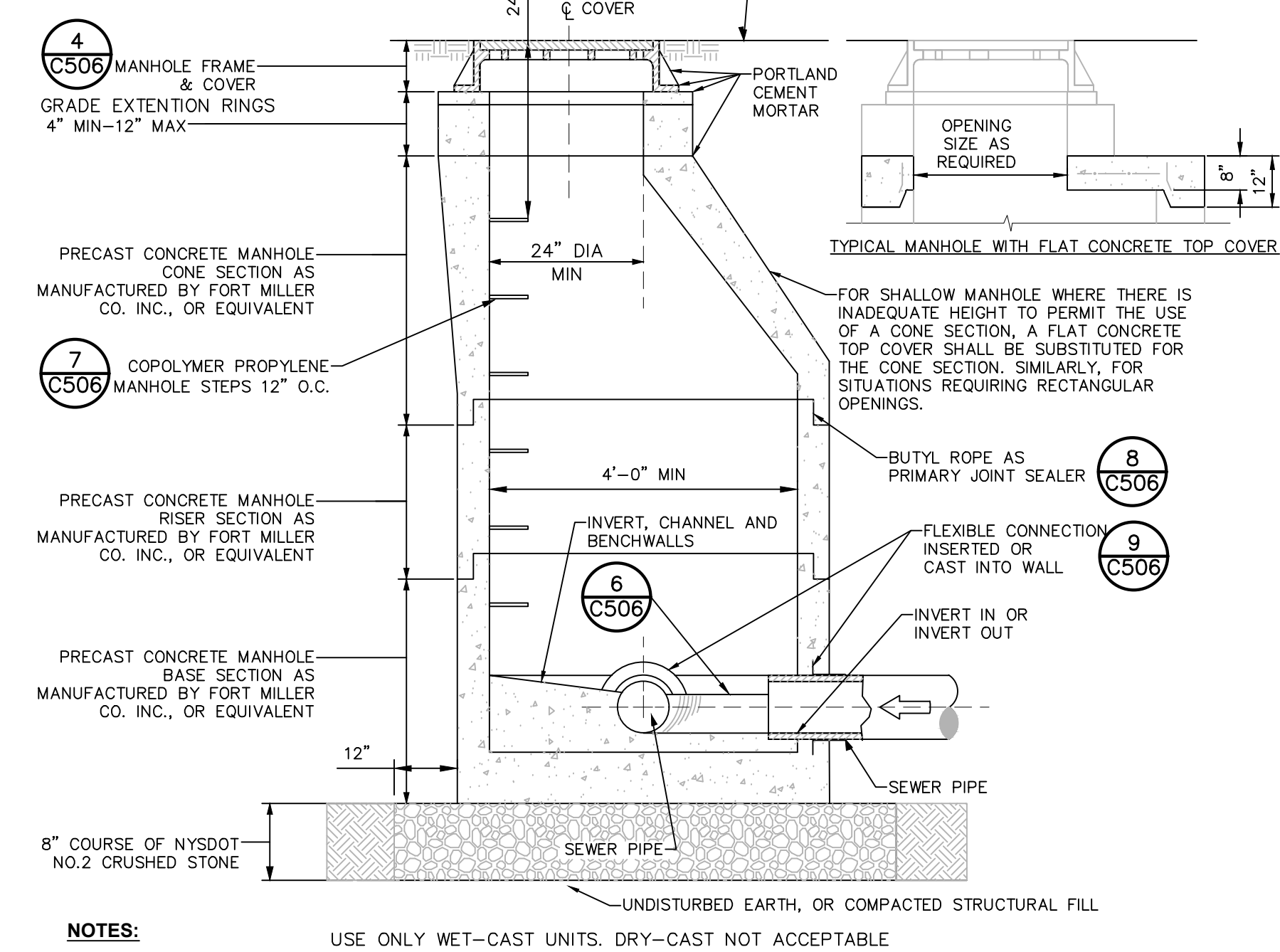

NOTE:
 REFERENCE MANHOLE DETAIL(S) FOR REQUIRED INVERT CHANNEL CONFIGURATION.

8 MANHOLE JOINT
 SCALE: NOT TO SCALE

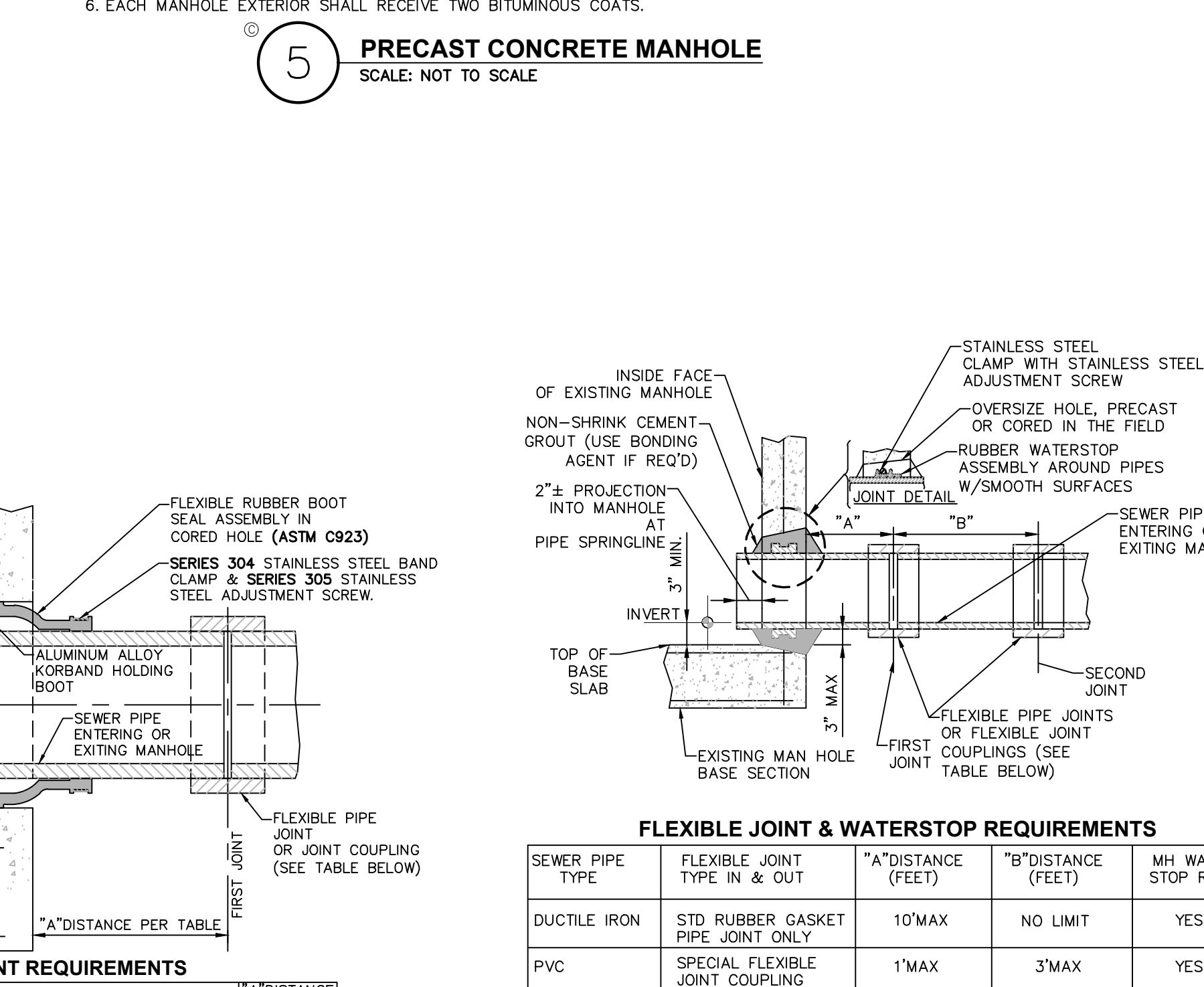

NOTE:
 REFERENCE MANHOLE DETAIL(S) FOR REQUIRED INVERT CHANNEL CONFIGURATION.

9 PIPE CONNECTION TO MANHOLE- PRECAST OR CORED HOLE W/ INSERTED FLEXIBLE BOOT
 SCALE: NOT TO SCALE

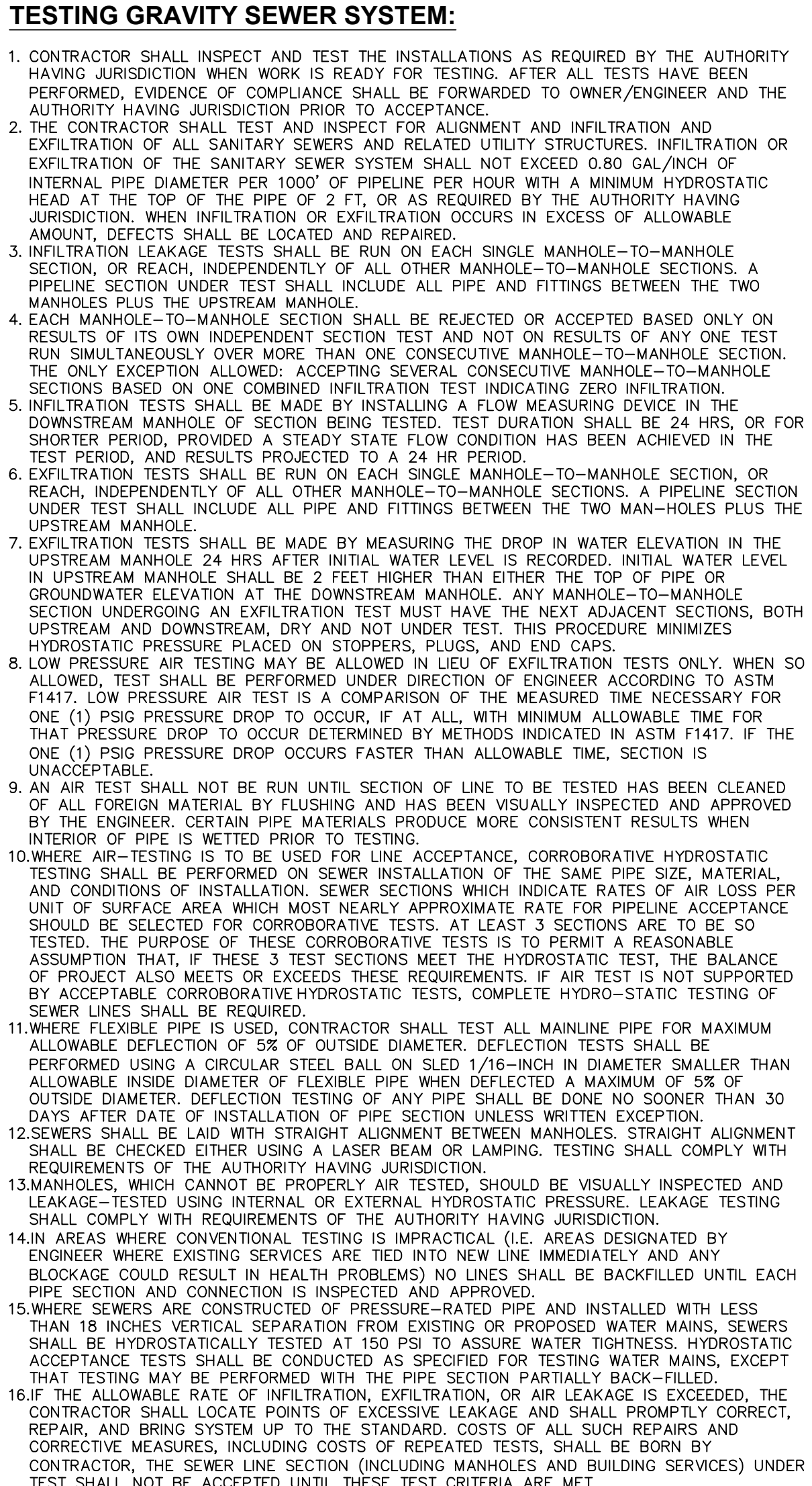

NOTE:
 1. THIS DETAIL SHALL BE USED AT NO EXTRA COST IN PLACE OF EITHER OF THE PIPE-TO-MANHOLE CONNECTION DETAILS ONLY WHEN CONNECTING TO EXISTING MANHOLES THAT HAVE NO FLEXIBLE RUBBER BOOT PROVIDED.
 2. REFERENCE MANHOLE DETAIL(S) FOR REQUIRED INVERT CHANNEL CONFIGURATION.

10 PIPE CONNECTION TO EXISTING MANHOLE- CEMENT GROUT SEAL WITH WATER STOP
 SCALE: NOT TO SCALE

TESTING GRAVITY SEWER SYSTEM:

- CONTRACTOR SHALL INSPECT AND TEST THE INSTALLATIONS AS REQUIRED BY THE AUTHORITY HAVING JURISDICTION WHEN WORK IS READY FOR TESTING. AFTER ALL TESTS HAVE BEEN PERFORMED, EVIDENCE OF COMPLIANCE SHALL BE FORWARDED TO OWNER/ENGINEER AND THE AUTHORITY HAVING JURISDICTION PRIOR TO ACCEPTANCE.
- THE CONTRACTOR SHALL TEST AND INSPECT FOR ALIGNMENT AND INFILTRATION AND EXFILTRATION OF ALL SANITARY SEWERS AND RELATED UTILITY STRUCTURES. INFILTRATION OR EXFILTRATION OF THE SANITARY SEWER SYSTEM SHALL NOT EXCEED 0.80 GAL./INCH OF INTERNAL PIPE DIAMETER PER 100' OF PIPELINE PER HOUR WITH A MINIMUM HYDROSTATIC HEAD AT THE TOP OF THE PIPE OF 2 FT. OR AS REQUIRED BY THE AUTHORITY HAVING JURISDICTION. WHEN INFILTRATION OR EXFILTRATION OCCURS IN EXCESS OF ALLOWABLE AMOUNT, DEFECTS SHALL BE LOCATED AND REPAIRED.
- INFILTRATION LEAKAGE TESTS SHALL BE RUN ON EACH SINGLE MANHOLE-TO-MANHOLE SECTION, OR REACH, INDEPENDENTLY OF ALL OTHER MANHOLE-TO-MANHOLE SECTIONS. A PIPELINE SECTION UNDER TEST SHALL INCLUDE ALL PIPE AND FITTINGS BETWEEN THE TWO MANHOLES PLUS THE UPSTREAM MANHOLE.
- EACH MANHOLE-TO-MANHOLE SECTION SHALL BE REJECTED OR ACCEPTED BASED ONLY ON RESULTS OF ITS OWN INDEPENDENT SECTION TEST AND NOT ON RESULTS OF ANY ONE TEST RUN SIMULTANEOUSLY OVER MORE THAN ONE CONSECUTIVE MANHOLE-TO-MANHOLE SECTION. THE ONLY EXCEPTION ALLOWED: ACCEPTING SEVERAL CONSECUTIVE MANHOLE-TO-MANHOLE SECTIONS BASED ON ONE COMBINED INFILTRATION TEST INDICATING ZERO INFILTRATION.
- INFILTRATION TESTS SHALL BE MADE BY INSTALLING A FLOW MEASURING DEVICE IN THE DOWNSTREAM MANHOLE OF SECTION BEING TESTED. TEST DURATION SHALL BE 24 HRS. OR FOR SHORTER PERIOD, PROVIDED A STEADY STATE FLOW CONDITION HAS BEEN ACHIEVED IN THE TEST PERIOD, AND RESULTS PROJECTED TO A 24 HR PERIOD.
- EXFILTRATION TESTS SHALL BE RUN ON EACH SINGLE MANHOLE-TO-MANHOLE SECTION, OR REACH, INDEPENDENTLY OF ALL OTHER MANHOLE-TO-MANHOLE SECTIONS. A PIPELINE SECTION UNDER TEST SHALL INCLUDE ALL PIPE AND FITTINGS BETWEEN THE TWO MANHOLES PLUS THE UPSTREAM MANHOLE.
- EXFILTRATION TESTS SHALL BE MADE BY MEASURING THE DROP IN WATER ELEVATION IN THE UPSTREAM MANHOLE 24 HRS AFTER INITIAL WATER LEVEL IS RECORDED. INITIAL WATER LEVEL IN UP-STREAM MANHOLE SHALL BE 2 FEET HIGHER THAN EITHER THE TOP OF PIPE OR GROUNDWATER ELEVATION AT THE DOWNSTREAM MANHOLE. ANY MANHOLE-TO-MANHOLE SECTION UNDERGOING AN EXFILTRATION TEST MUST HAVE THE NEXT ADJACENT SECTIONS, BOTH UPSTREAM AND DOWNSTREAM, DRY AND NOT UNDER TEST. THIS PROCEDURE MINIMIZES HYDROSTATIC PRESSURE PLACED ON STOPPERS, PLUGS, AND END CAPS.
- LOW PRESSURE AIR TESTING MAY BE ALLOWED IN LIEU OF EXFILTRATION TESTS ONLY, WHEN SO ALLOWED, TEST SHALL BE PERFORMED UNDER DIRECTION OF ENGINEER ACCORDING TO ASTM F1417. LOW PRESSURE AIR TEST IS A COMPARISON OF THE MEASURED TIME NECESSARY FOR ONE (1) PSIG PRESSURE DROP TO OCCUR, IF AT ALL, WITH MINIMUM ALLOWABLE TIME FOR THAT PRESSURE DROP TO OCCUR DETERMINED BY METHODS INDICATED IN ASTM F1417. IF THE ONE (1) PSIG PRESSURE DROP OCCURS FASTER THAN ALLOWABLE TIME, SECTION IS UNACCEPTABLE.
- AN AIR TEST SHALL NOT BE RUN UNTIL SECTION OF LINE TO BE TESTED HAS BEEN CLEANED OF ALL FOREIGN MATERIAL BY FLUSHING AND HAS BEEN VISUALLY INSPECTED AND APPROVED BY THE ENGINEER. CERTAIN PIPE MATERIALS PRODUCE MORE CONSISTENT RESULTS WHEN INTERIOR OF PIPE IS WETTED PRIOR TO TESTING.
- WHERE AIR-TESTING IS TO BE USED FOR LINE ACCEPTANCE, CORROBORATIVE HYDROSTATIC TESTING SHALL BE PERFORMED ON SEWER INSTALLATION OF THE SAME PIPE SIZE, MATERIAL, AND CONDITIONS OF INSTALLATION. SEWER SECTIONS WHICH INDICATE RATES OF AIR LOSS PER UNIT OF SURFACE AREA WHICH MOST NEARLY APPROXIMATE RATE FOR PIPELINE ACCEPTANCE SHOULD BE SELECTED FOR CORROBORATIVE TESTS. AT LEAST 3 SECTIONS ARE TO BE SO TESTED. THE PURPOSE OF THESE CORROBORATIVE TESTS IS TO PERMIT A REASONABLE ASSUMPTION THAT IF THESE 3 TEST SECTIONS MEET THE HYDROSTATIC TEST, THE BALANCE OF PROJECT ALSO MEETS OR EXCEEDS THESE REQUIREMENTS. IF AIR TEST IS NOT SUPPORTED BY ACCEPTABLE CORROBORATIVE HYDROSTATIC TESTS, COMPLETE HYDRO-STATIC TESTING OF SEWER LINES SHALL BE REQUIRED.
- WHERE FLEXIBLE PIPE IS USED, CONTRACTOR SHALL TEST ALL MAINLINE PIPE FOR MAXIMUM ALLOWABLE DEFLECTION OF 5% OF OUTSIDE DIAMETER. DEFLECTION TESTS SHALL BE PERFORMED USING A CIRCULAR STEEL BALL ON SLED 1/16-INCH IN DIAMETER SMALLER THAN ALLOWABLE INSIDE DIAMETER OF FLEXIBLE PIPE WHEN DEFLECTED A MAXIMUM OF 5% OF OUTSIDE DIAMETER. DEFLECTION TESTING OF ANY PIPE SHALL BE DONE NO SOONER THAN 30 DAYS AFTER DATE OF INSTALLATION OF PIPE SECTION UNLESS WRITTEN EXCEPTION.
- SEWERS SHALL BE LAID WITH MINIMUM SLOPE ALIGNMENT BETWEEN MANHOLES. STRAIGHT ALIGNMENT SHALL BE CHECKED EITHER USING A LASER BEAM OR LAMPING. TESTING SHALL COMPLY WITH REQUIREMENTS OF THE AUTHORITY HAVING JURISDICTION.
- MANHOLES, WHICH CANNOT BE PROPERLY AIR TESTED, SHOULD BE VISUALLY INSPECTED AND LEAKAGE-TESTED USING INTERNAL OR EXTERNAL HYDROSTATIC PRESSURE. LEAKAGE TESTING SHALL COMPLY WITH REQUIREMENTS OF THE AUTHORITY HAVING JURISDICTION.
- IN AREAS WHERE CONVENTIONAL TESTING IS IMPRACTICAL (I.E. AREAS DESIGNATED BY ENGINEER WHERE EXISTING SERVICES ARE TIED INTO NEW LINE IMMEDIATELY AND ANY BLOCKAGE COULD RESULT IN HEALTH PROBLEMS) NO LINE SHALL BE BACKFILLED UNTIL EACH PIPE SECTION AND CONNECTION IS INSPECTED AND APPROVED.
- WHERE SEWERS ARE CONSTRUCTED OF PRESSURE-RATED PIPE AND INSTALLED WITH LESS THAN 18 INCHES VERTICAL SEPARATION FROM EXISTING OR PROPOSED WATER MAINS, SEWERS SHALL BE HYDROSTATICALLY TESTED AT 150 PSI TO ASSURE WATER TIGHTNESS. HYDROSTATIC ACCEPTANCE TESTS SHALL BE CONDUCTED AS SPECIFIED FOR TESTING WATER MAINS, EXCEPT THAT TESTING MAY BE PERFORMED WITH THE PIPE SECTION PARTIALLY BACK-FILLED.
- IF THE ALLOWABLE RATE OF INFILTRATION, EXFILTRATION, OR AIR LEAKAGE IS EXCEEDED, THE CONTRACTOR SHALL LOCATE POINTS OF EXCESSIVE LEAKAGE AND SHALL PROMPTLY CORRECT, REPAIR, AND BRING SYSTEM UP TO THE STANDARD. COSTS OF ALL SUCH REPAIRS AND CORRECTIVE MEASURES, INCLUDING COSTS OF REPEATED TESTS, SHALL BE BORN BY CONTRACTOR. THE SEWER LINE SECTION (INCLUDING MANHOLES AND BUILDING SERVICES) UNDER TEST SHALL NOT BE ACCEPTED UNTIL THESE TEST CRITERIA ARE MET.

MANHOLES AND OTHER BELOW GRADE STRUCTURES:

- STRUCTURAL DESIGN FOR MANHOLES AND OTHER BELOW-GRADE PRECAST CONCRETE STRUCTURES:
 A. NON-TRAFFIC LOADS:
 BELOW GRADE PRECAST CONCRETE STRUCTURES SHALL BE DESIGNED TO WITHSTAND LOADS IMPOSED BY STRUCTURE WEIGHT, EARTH COVER, LATERAL PRESSURE FROM EARTH AND GROUND WATER, AND LIVE LOADS SUCH AS PEDESTRIAN TRAFFIC OR MACHINERY ON OR ABOVE THE STRUCTURE; AND
 B. TRAFFIC LOADS:
 BELOW GRADE PRECAST CONCRETE STRUCTURES SHALL BE DESIGNED TO ALSO WITHSTAND TRAFFIC LOADS CREATED BY AN HS20-44 TRUCK PLUS 25% IMPACT AS DEFINED IN THE LATEST EDITION OF THE AMERICAN ASSOCIATION OF STATE HIGHWAY AND TRANSPORTATION OFFICIALS (AASHTO) DESIGN STANDARDS.
- MATERIAL WHICH SHALL BE UTILIZED IN THE CONSTRUCTION OF PRECAST CONCRETE STRUCTURES:
 CEMENT: ASTM C-150, TYPES I,II,III,VI
 SAND: NYS DOT STD. SPEC. SECTION NO. 703-0 CONCRETE SAND
 STONE: NYS DOT STD. SPEC. SECTION NO. 703-02 COARSE AGGREGATE
 STEEL BAR REINFORCEMENT: ASTM A615, GRADE 60
 WIRE MESH REINFORCEMENT: ASTM A185 PLAIN
 CONCRETE STRENGTH (28 DAY): 4,500 PSI (F'C)
 ENTRAINED AIR: 5% MIN.
- ALL CASTINGS (FRAMES AND COVERS, FRAMES AND GRATES, ETC.) FOR USE IN CONJUNCTION WITH MANHOLES AND OTHER BELOW GRADE STRUCTURES SHALL BE MANUFACTURED FROM GRAY IRON OR DUCTILE IRON. GRAY IRON SHALL CONFORM WITH ASTM A 48, CLASS 30B AND DUCTILE IRON SHALL CONFORM WITH ASTM A 536 AND BE OF A GRADE APPROPRIATE TO ITS INTENDED USE.
- ALL CASTINGS (FRAMES AND COVERS, FRAMES AND GRATES, ETC.) FOR USE IN CONJUNCTION WITH MANHOLES AND OTHER BELOW GRADE STRUCTURES SHALL BE DESIGNED TO WITHSTAND AASHTO HS 20-44 HIGHWAY LOADING PLUS 25% IMPACT.
- ALL ASTM REFERENCES SHALL BE FOR THE LATEST ACTIVE STANDARD.

THE SEVENTY-SIX

Parcel 76, 76 Second Avenue, City of Albany, NY

Owner: South End Development LLC

Architect: Garrison-Architects
 45 Main Street
 Brooklyn, NY 11201

Civil Engineer: The Chazen Companies
 547 River St,
 Troy, NY 12180
 p (518) 273-0055
 Chazen Project No. 32019.00

Revision Schedule

Revision Number	Revision Description	Revision Date
-----------------	----------------------	---------------

Schematic Design

Scale: AS NOTED
 Date: 06/23/2020
 Project No: 2005
 Drawn by: KC/SM
 Checked by: RK

Seal & Signature:

DOB Stamp & Signature

DOB Scan:

Drawing Title:

Sanitary Sewer System Details

Drawing Number:

C-506

DWG.No:

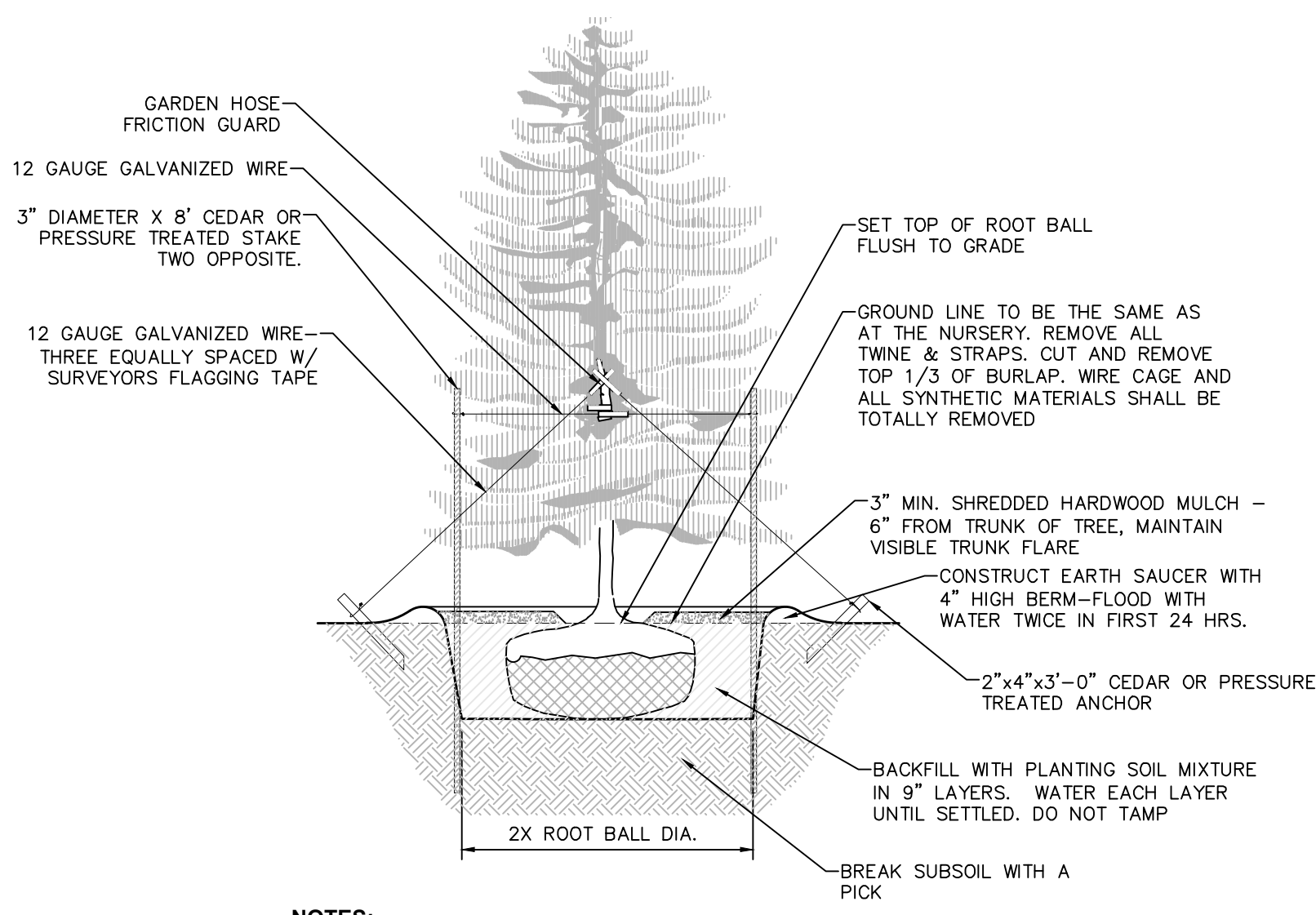

- NOTES:**
1. SPRAY WITH ANTIDESSICANT IN ACCORDANCE WITH MFG.'S RECOMMENDATIONS.
 2. TREES LESS THAN 3\"/>

1 EVERGREEN PLANTING DETAIL
SCALE: NOT TO SCALE

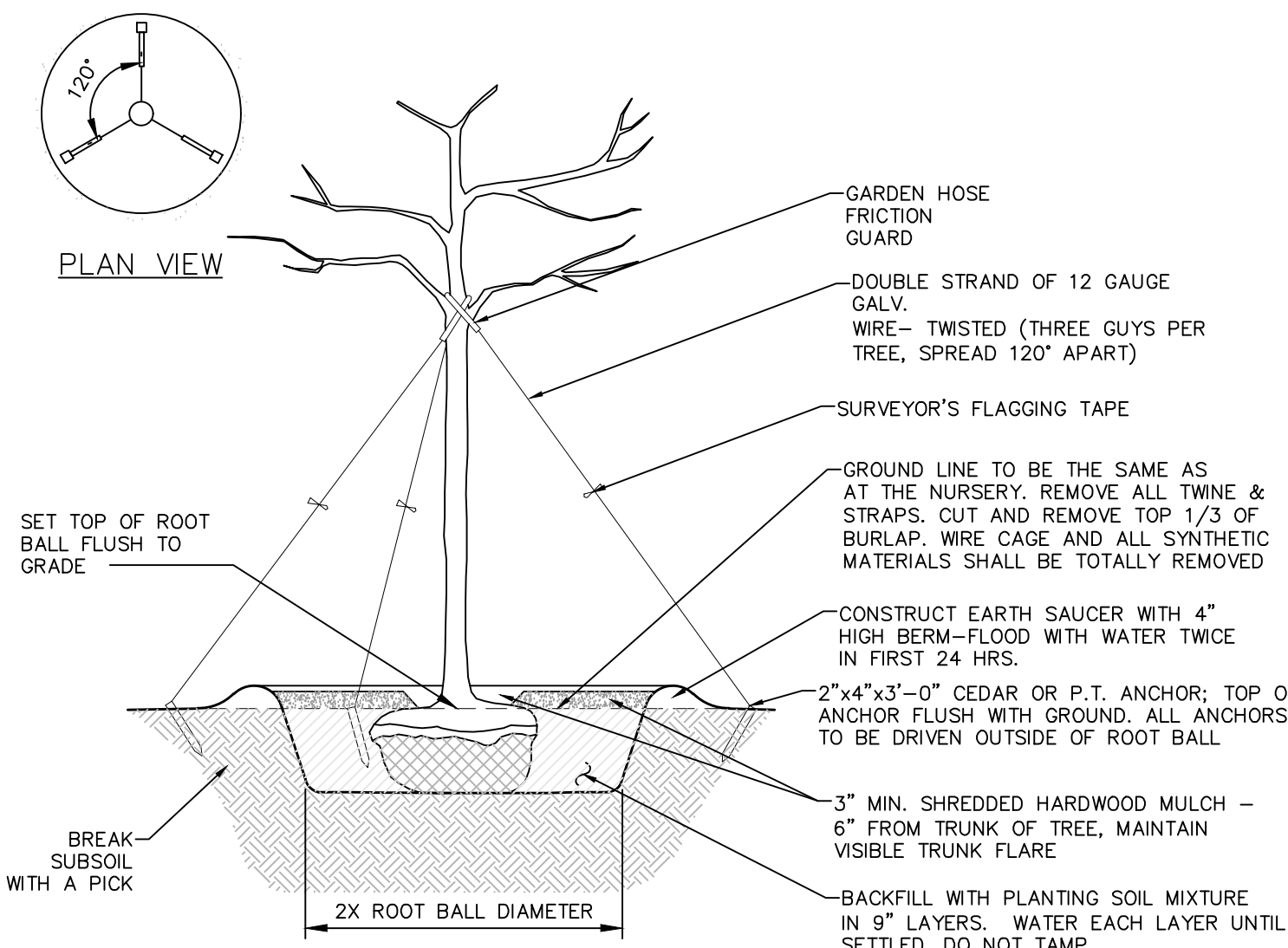

- NOTE:** STAKES SHALL BE REMOVED AT THE END OF THE FIRST GROWING SEASON AFTER PLANTING
- 2 PLANTING AND GUYING DETAILS FOR TREES 3\"/>**

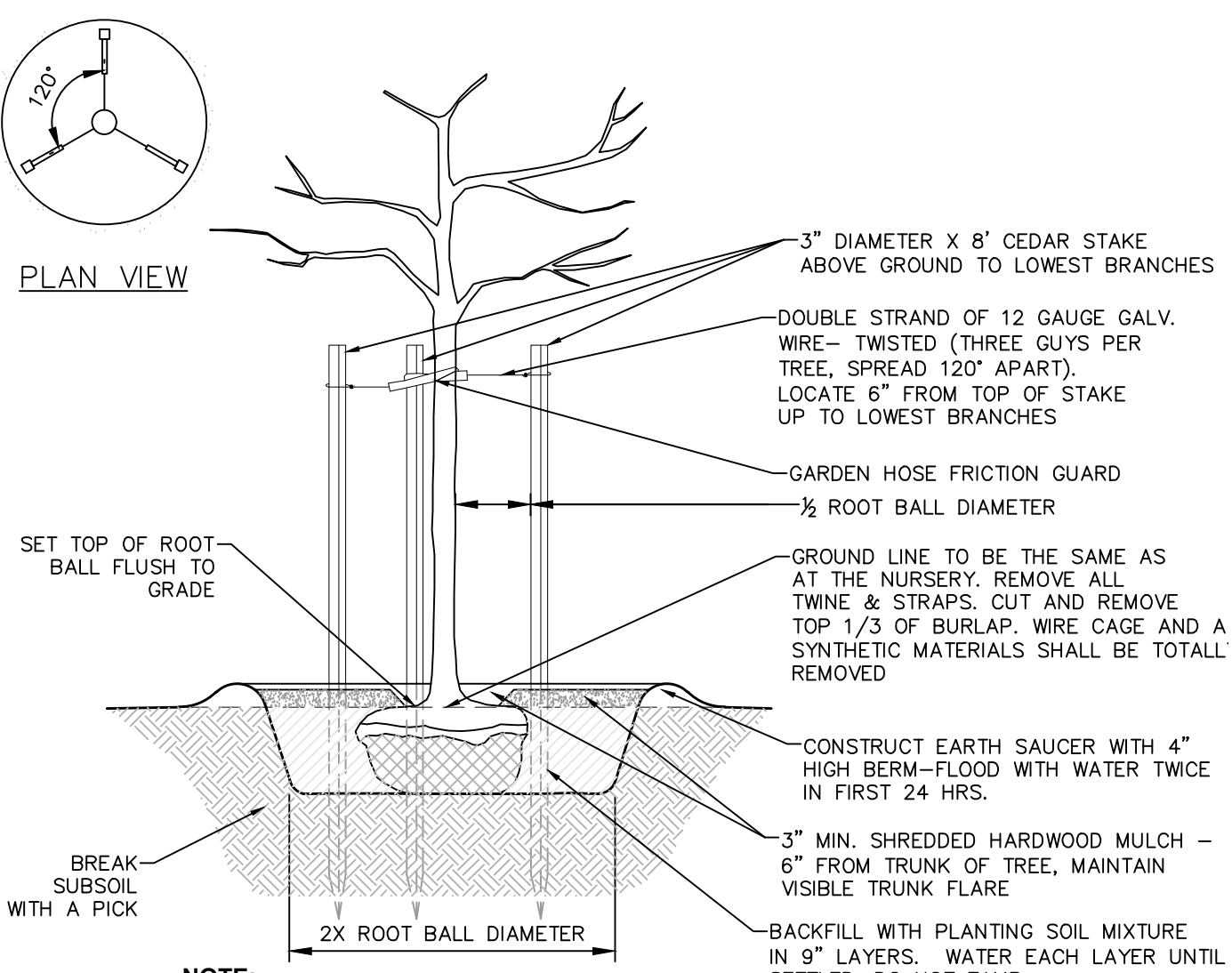

- NOTE:** STAKES SHALL BE REMOVED AT THE END OF THE FIRST GROWING SEASON AFTER PLANTING
- 3 PLANTING AND GUYING DETAILS FOR TREES SMALLER THAN 3\"/>**

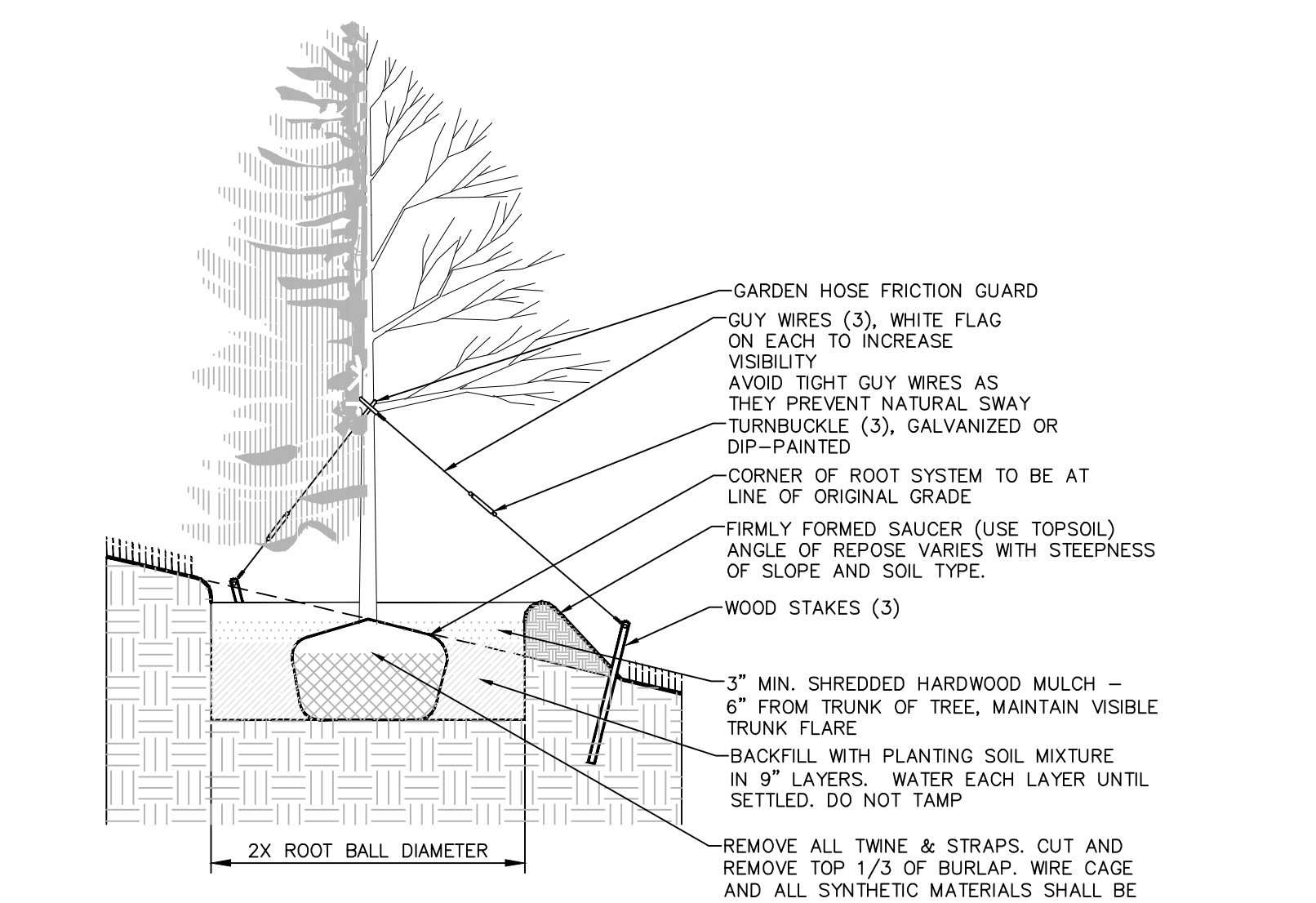

4 TREE PLANTING ON SLOPE
SCALE: NOT TO SCALE

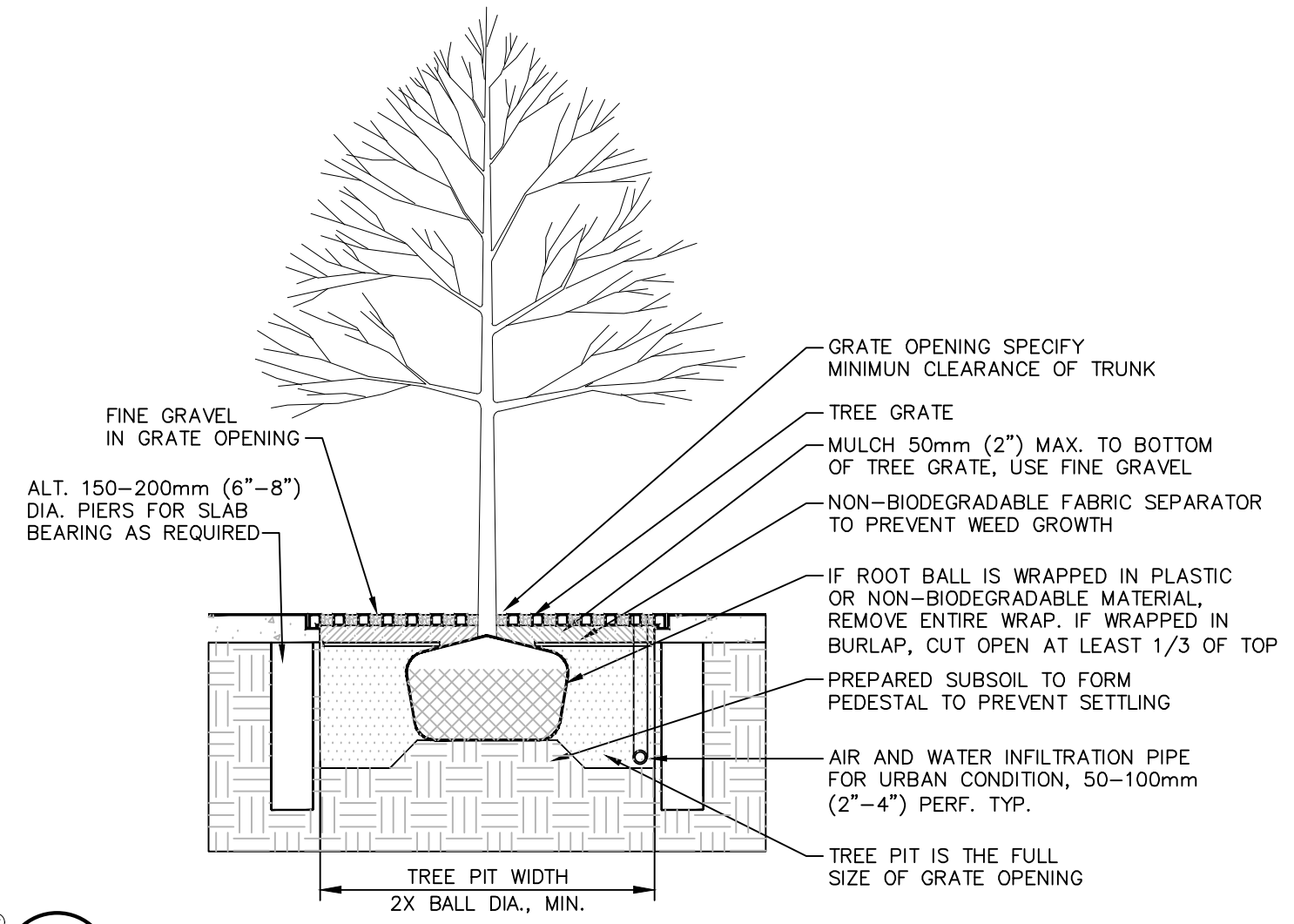

5 DECIDUOUS TREE PLANTING IN PAVEMENT WITH METAL GRATE
SCALE: NOT TO SCALE

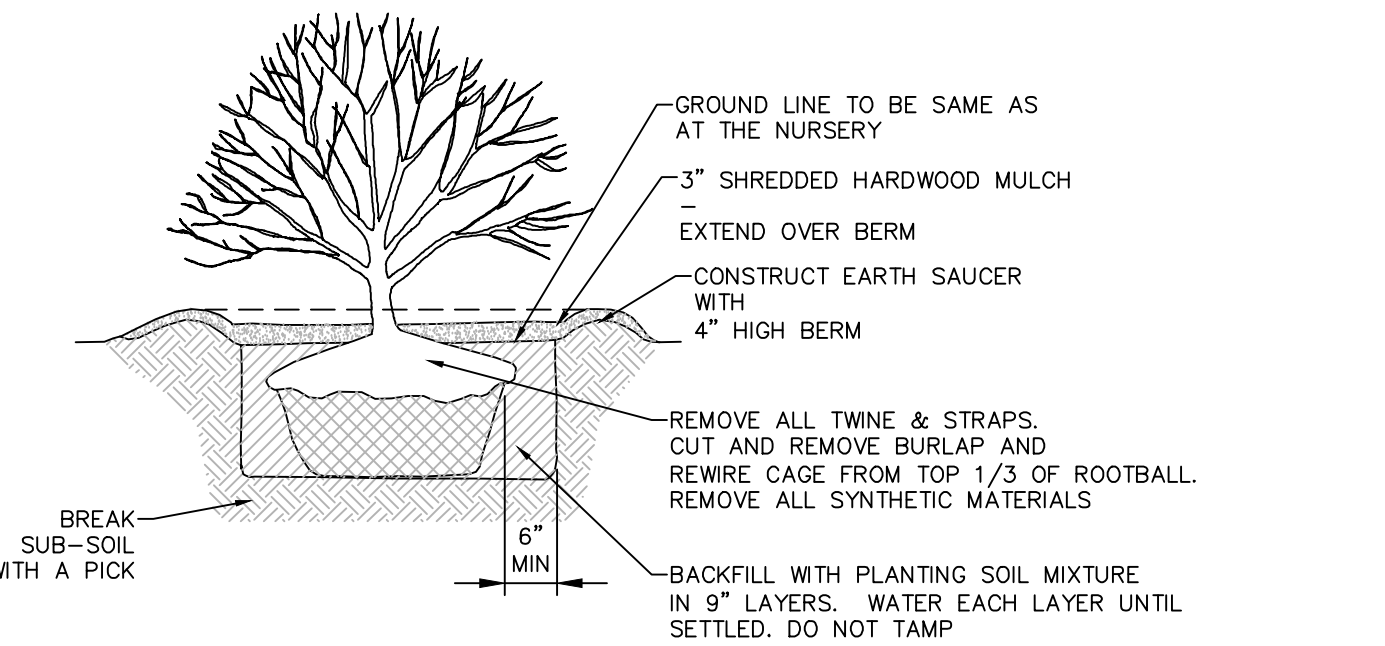

6 SHRUB PLANTING DETAIL FOR ALL SHRUBS BALLED AND BURLAPPED
SCALE: NOT TO SCALE

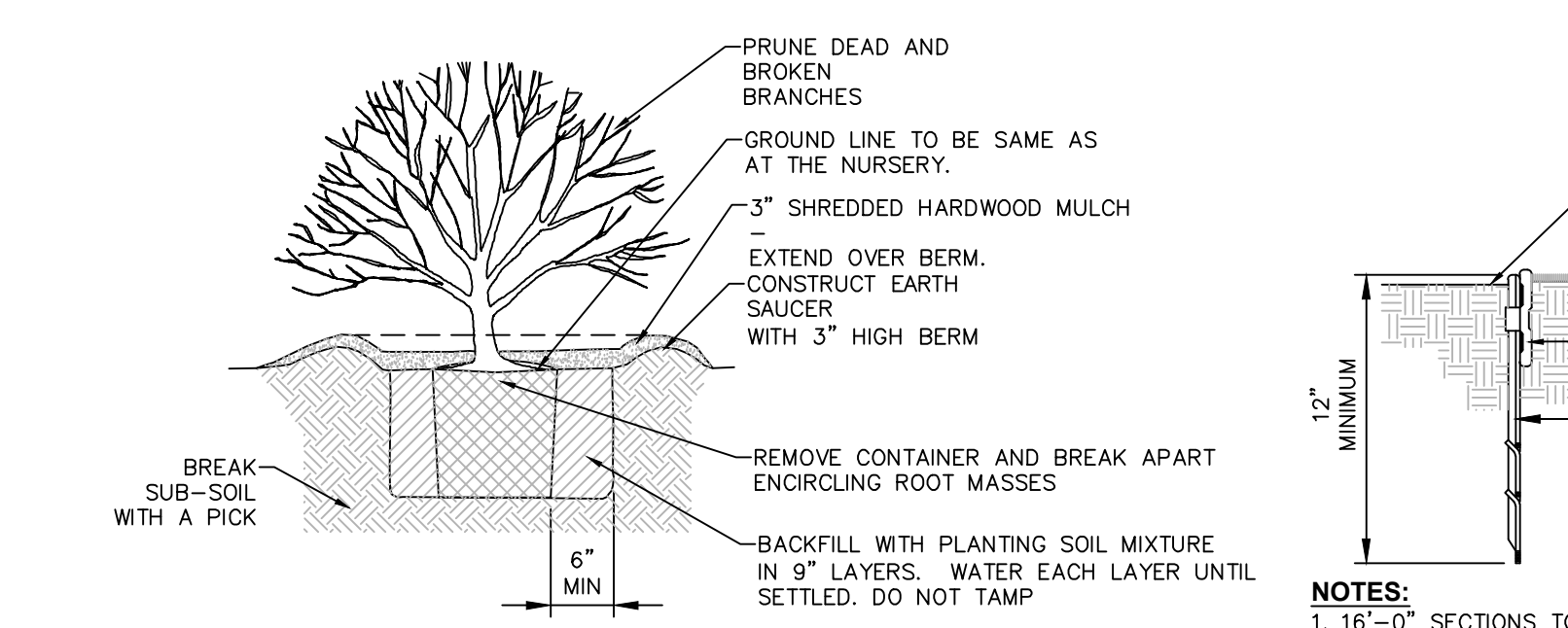

7 SHRUB PLANTING DETAIL FOR CONTAINERIZED SHRUBS
SCALE: NOT TO SCALE

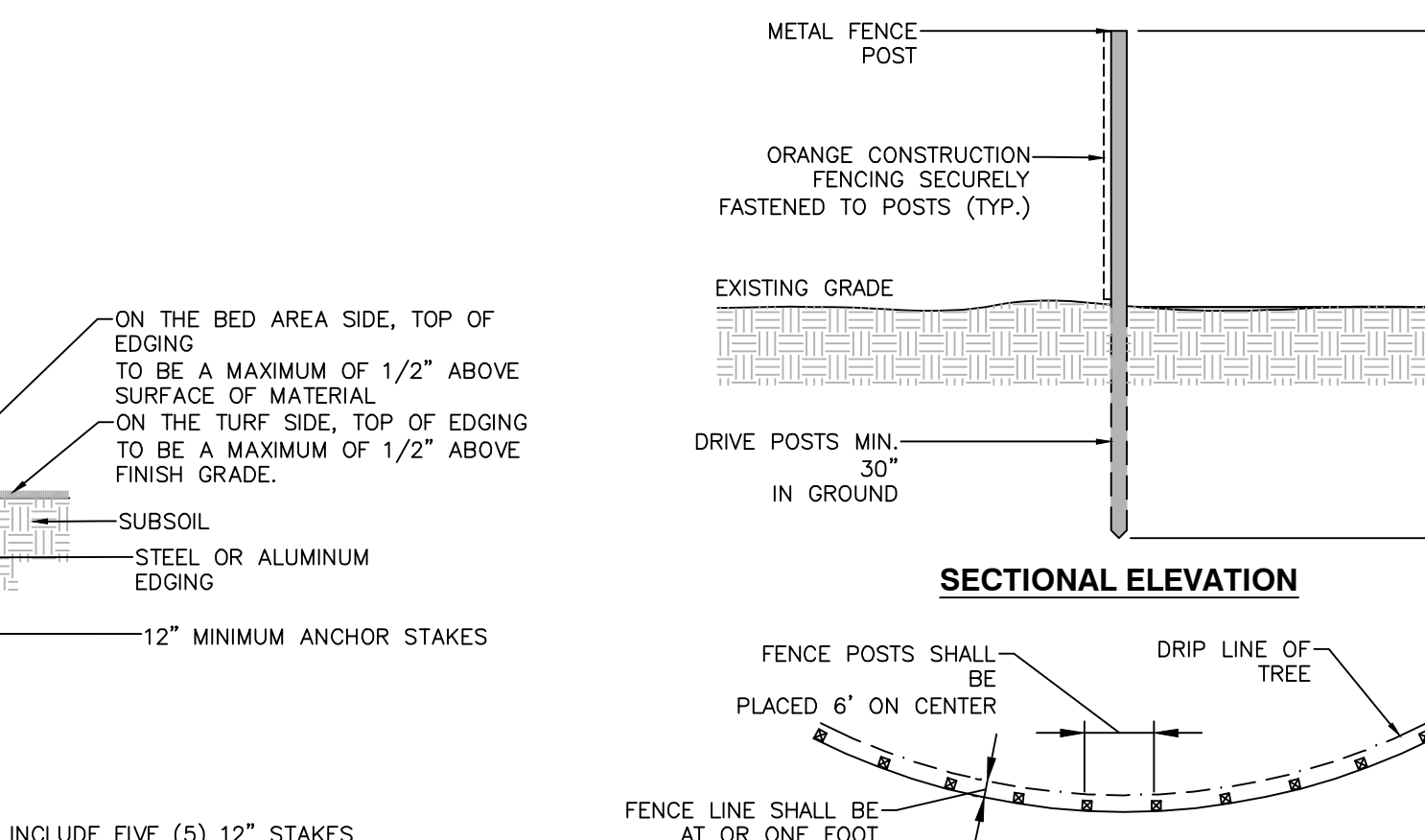

8 LANDSCAPE BED EDGING
SCALE: NOT TO SCALE

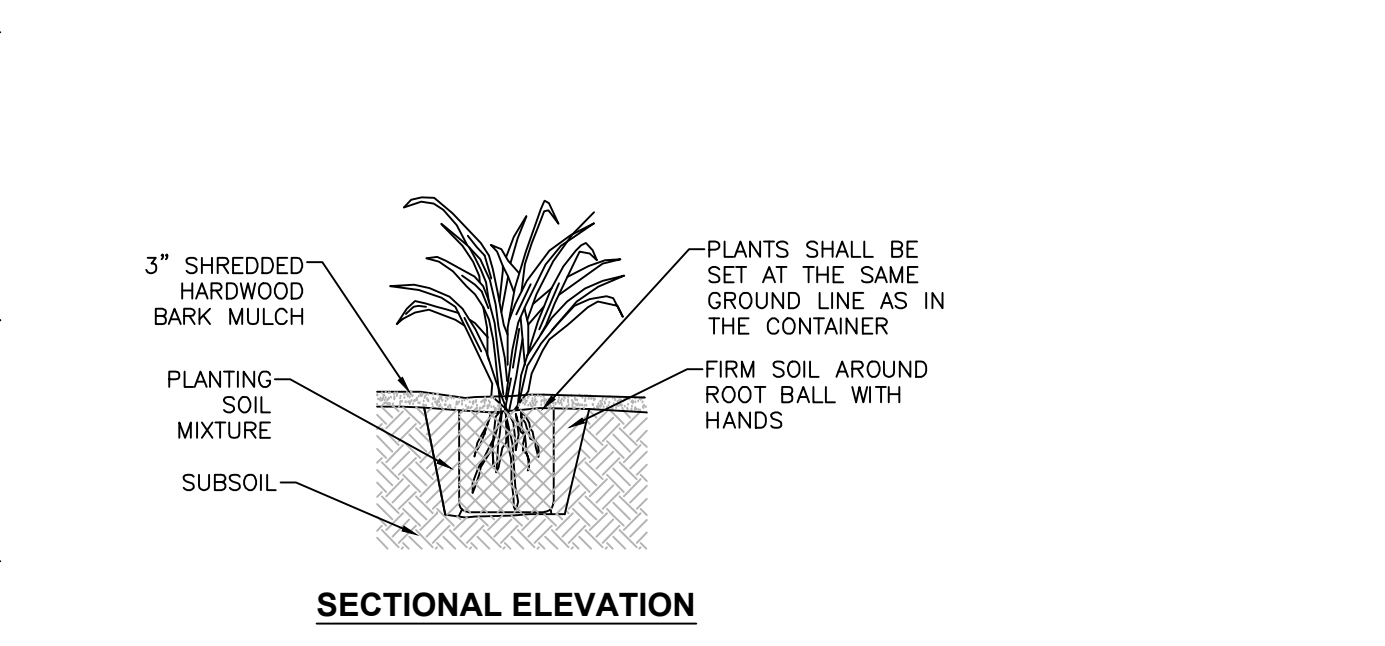

9 TREE PROTECTION FENCING DETAIL
SCALE: NOT TO SCALE

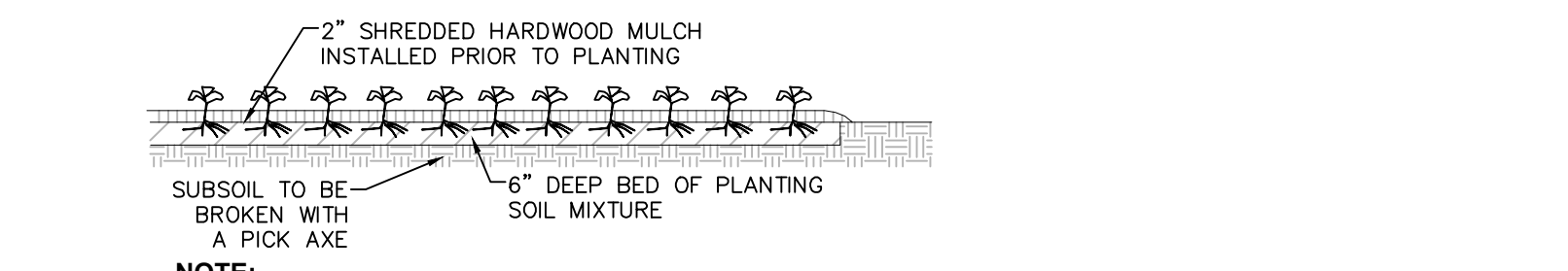

10 CONTAINERIZED PERENNIAL PLANTING
SCALE: NOT TO SCALE

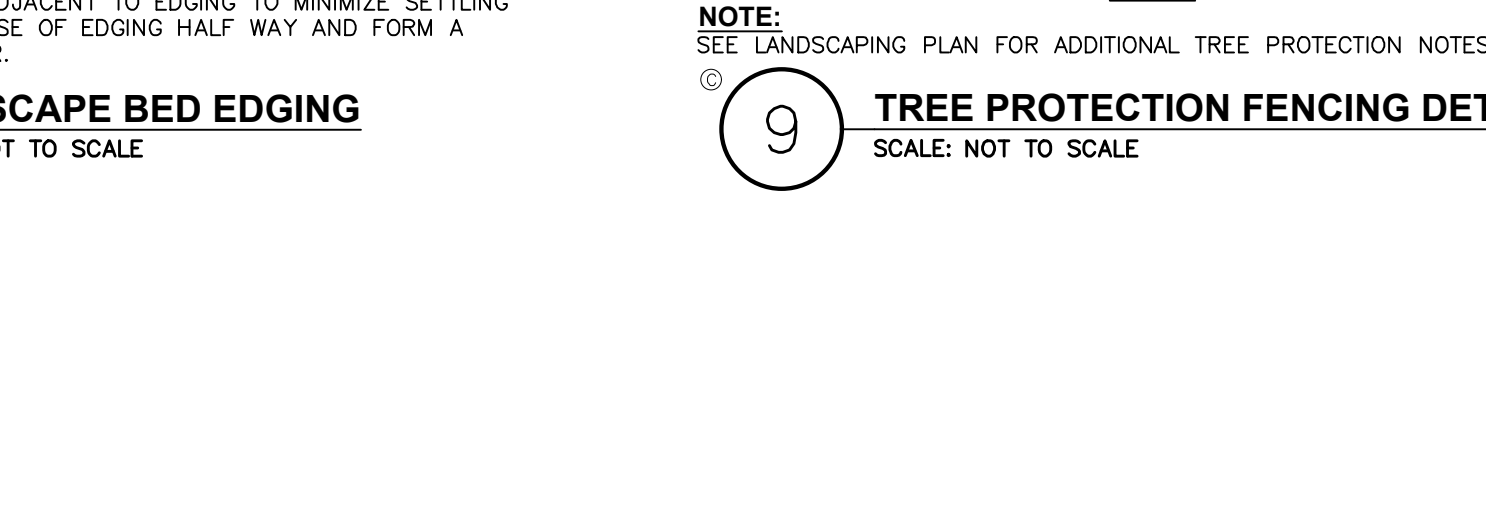

11 GROUND COVER/ANNUAL PLUG PLANTING
SCALE: NOT TO SCALE

LANDSCAPING NOTES:

1. THE LANDSCAPE CONTRACTOR SHALL CAREFULLY COORDINATE CONSTRUCTION ACTIVITIES WITH THAT OF THE EARTHWORK CONTRACTOR AND OTHER SITE DEVELOPMENT.
2. THE CONTRACTOR SHALL VERIFY DRAWING DIMENSIONS WITH ACTUAL FIELD CONDITIONS AND INSPECT RELATED WORK AND ADJACENT SURFACES. THE CONTRACTOR SHALL VERIFY THE ACCURACY OF ALL FINISH GRADES WITHIN THE WORK AREA. THE CONTRACTOR SHALL REPORT TO THE LANDSCAPE ARCHITECT/ENGINEER AND OWNER ALL CONDITIONS WHICH PREVENT PROPER EXECUTION OF THIS WORK.
3. THE EXACT LOCATION OF ALL EXISTING UTILITIES, STRUCTURES AND UNDERGROUND UTILITIES, WHICH MAY NOT BE INDICATED ON THE DRAWINGS, SHALL BE DETERMINED BY THE CONTRACTOR. THE CONTRACTOR SHALL PROTECT EXISTING STRUCTURES AND UTILITY SERVICES AND IS RESPONSIBLE FOR THEIR REPLACEMENT IF DAMAGED.
4. THE CONTRACTOR SHALL KEEP THE PREMISES FREE FROM RUBBISH AND ALL DEBRIS AT ALL TIMES AND SHALL ARRANGE MATERIAL STORAGE SO AS NOT TO INTERFERE WITH THE OPERATION OF THE PROJECT. ALL UNUSED MATERIALS, RUBBISH AND DEBRIS SHALL BE REMOVED FROM THE SITE.
5. NO TREES OR SHRUBS SHALL BE PLANTED ON EXISTING OR PROPOSED UTILITY LINES.
6. QUALITY ASSURANCE:
 - A. NOMENCLATURE: PLANT NAMES SHALL CONFORM TO THE LATEST EDITION OF "STANDARDIZED PLANT NAMES" AS ADOPTED BY THE AMERICAN JOINT COMMITTEE ON HORTICULTURAL NOMENCLATURE.
 - B. SIZE AND GRADING: PLANT SIZES AND GRADING SHALL CONFORM TO THE LATEST EDITION OF "AMERICAN STANDARD FOR NURSERY STOCK" AS SPONSORED BY THE AMERICAN ASSOCIATION OF NURSEYMEN, INC. (AAN), UNLESS OTHERWISE SPECIFIED.
 - C. NURSERY SOURCE: OBTAIN FRESHLY DUG, HEALTHY, VIGOROUS PLANTS NURSERY GROWN UNDER CLIMATIC CONDITIONS SIMILAR TO THOSE IN THE LOCALITY OF THE PROJECT FOR A MINIMUM OF 2 YEARS. PLANTS SHALL HAVE BEEN LINED OUT IN ROWS, ANNUALLY CULTIVATED, SPRAYED, PRUNED AND FERTILIZED IN ACCORDANCE WITH GOOD HORTICULTURAL PRACTICE. ALL PLANTS SHALL HAVE BEEN TRANSPLANTED OR ROOT PRUNED AT LEAST ONCE IN THE PAST 3 YEARS. SALLED AND BURLAPPED PLANTS MUST COME FROM SOIL WHICH WILL HOLD A FIRM ROOT BALL. HEELED IN PLANTS AND PLANTS FROM COLD STORAGE ARE NOT ACCEPTABLE.
 - D. SUBSTITUTIONS: DO NOT MAKE SUBSTITUTIONS OF TREES AND/OR SHRUB MATERIALS. IF REQUIRED LANDSCAPE MATERIAL IS NOT OBTAINABLE, SUBMIT PROOF OF NON-AVAILABILITY AND PROPOSAL FOR USE OF EQUIVALENT MATERIAL. WHEN AUTHORIZED, ADJUSTMENTS OF CONTRACT AMOUNT (IF ANY) WILL BE MADE BY CHANGE ORDER.
7. SEEDING & PLANTING SEASONS AND TIMING CONDITIONS:
 - A. UNLESS OTHERWISE DIRECTED IN WRITING, SEED LAWNS FROM MARCH 15 TO JUNE 15, AND FROM AUGUST 15 TO OCTOBER 15.
 - B. UNLESS OTHERWISE DIRECTED IN WRITING PLANT TREES AND SHRUBS FROM MARCH 15 TO JUNE 15 AND FROM AUGUST 15 TO OCTOBER 30.
 - C. AREAS UNDERGOING CLEARING OR GRADING AND ANY AREAS DISTURBED BY CONSTRUCTION ACTIVITIES WHERE LAWNS OR PLANTINGS ARE TO BE ESTABLISHED AND WORK IS COMPLETE, SHALL BE RESTORED WITH PERMANENT VEGETATIVE COVER AS SOON AS SITE AREAS ARE AVAILABLE AND WITHIN 14 DAYS AFTER WORK IS COMPLETE. WORK SHALL BE WITHIN THE SEASONAL LIMITATIONS FOR EACH KIND OF LANDSCAPE WORK REQUIRED. PROVIDE STABILIZATION WITH TEMPORARY VEGETATIVE COVER (TOPSOIL AND TEMPORARY COVER SEED MIX) WITHIN 14 DAYS AFTER WORK IS COMPLETE, FOR SEEDING OUTSIDE PERMITTED SEEDING PERIODS.
8. PRODUCTS:
 - A. IMPORTED TOPSOIL: PROVIDE TOPSOIL CONFORMING TO THE FOLLOWING:
 - i. OAM TOPSOIL: WELL DRAINED HOMOGENEOUS TEXTURE AND OF UNIFORM GRADE, WITHOUT THE ADMIXTURE OF SUBSOIL MATERIAL AND FREE OF DENSE MATERIAL, HARDPAN, CLAY, STONES, SOD OR OTHER OBJECTIONABLE MATERIAL.
 - ii. CONTAINING NOT LESS THAN 5% NOR MORE THAN 20% ORGANIC MATTER IN THAT PORTION OF A SAMPLING PASSING A 1/4" SIEVE WHEN DETERMINED BY THE WET COMBUSTION METHOD ON A SAMPLE DRIED AT 105°C.
 - iii. CONTAINING A PH VALUE WITHIN THE RANGE OF 6.5 TO 7.5 ON THAT PORTION OF THE SAMPLE WHICH PASSES A 1/4" SIEVE.
 - iv. CONTAINING THE FOLLOWING WASHED GRADATIONS:

SIEVE DESIGNATION	% PASSING
1"	100
1/4"	97-100
NO 200	20-60
 - B. SEED MIXTURE: PROVIDE FRESH, CLEAN, NEW-CROP SEED MIXED IN THE PROPORTIONS SPECIFIED FOR SPECIES AND VARIETY, AND CONFORMING TO FEDERAL AND STATE STANDARDS. PROVIDE THE FOLLOWING MIXTURES:
 - i. LAWN SEED MIX

SUN AND PARTIAL SHADE:			
AMOUNT BY WEIGHT	SPECIES OR VARIETY	MINIMUM PURITY	% GERMINATION
50%	KENTUCKY BLUE GRASS**	95%	80%
20%	PERENNIAL RYE	90%	90%
30%	CREeping RED FESCUE	97%	85%
100%			
**MINIMUM 2 (EQUAL PROPORTIONS) VARIETIES AS LISTED IN CORNELL RECOMMENDATIONS FOR TURFGRASS.			
SHADE:			
AMOUNT BY WEIGHT	SPECIES OR VARIETY	MINIMUM PURITY	% GERMINATION
25%	KENTUCKY BLUE GRASS**	95%	80%
20%	PERENNIAL RYE	98%	90%
35%	CREeping RED FESCUE	97%	85%
20%	CHEWINGS RED FESCUE	97%	85%
100%			
**SHADE TOLERANT VARIETY			
 - ii. TEMPORARY COVER SEED MIX

AMOUNT BY WEIGHT	SPECIES OR VARIETY	MINIMUM PURITY	% GERMINATION
100%	ANNUAL RYEGRASS	98%	90%
 - C. LIME: NATURAL LIMESTONE CONTAINING AT LEAST 85% OF TOTAL CARBONATES, GROUND TO SUCH FINENESS THAT AT LEAST 90% PASSES A 10-MESH SIEVE AND AT LEAST 50% PASSES A 100-MESH SIEVE.
 - D. FERTILIZER:
 - i. FOR STARTER FERTILIZING: COMMERCIAL STARTER FERTILIZER, GRANULAR, NONBURNING PRODUCT CONTAINING 5% NITROGEN, 10% AVAILABLE PHOSPHOROUS, AND 5% WATER SOLUBLE POTASH (5-10-5).
 - ii. FOR FINAL FERTILIZING: IF APPLIED IN SPRING SEASON, SHALL BE A SLOW RELEASE COMMERCIAL FERTILIZER, GRANULAR, WITH 3-1-2 NPK. IF APPLIED IN FALL SEASON, SHALL BE AS SPECIFIED IN (8.D.1) ABOVE.
 - E. TREES, SHRUBS, GROUND COVERS, PERENNIALS, ANNUALS:
 - i. PLANTING SOIL MIXTURE: SHALL BE PREMIXED IN BULK, AND CONTAIN THE FOLLOWING BY VOLUME:

30 PARTS	TOPSOIL
10 PARTS	PEAT
1 PART	BONE MEAL
 - ii. PEAT: BROWN TO BLACK IN COLOR, WEED AND SEED FREE. DRIED SPHAGNUM PEAT, CONTAINING NOT MORE THAN 9% MINERAL ON A DRY BASIS AND CONFORMING TO NYSDOT 713-15.
 - iii. BONE MEAL: FINELY GROUND, RAW, MINIMUM 4% NITROGEN AND 20% PHOSPHORIC ACID. IT SHALL BE DELIVERED IN SEALED BAGS SHOWING THE MANUFACTURER'S GUARANTEED ANALYSIS.
 - F. STAKES: 8 FEET LONG, 3 INCH DIA. CEDAR OR P.T. WOOD STAKES.
 - G. HOSE: NEW, 2-PLY GARDEN HOSE NOT LESS THAN 1/2 INCH IN DIAMETER.
 - H. WEED CONTROL FABRIC: SOIL CHECK AS MANUFACTURED BY BRIGHTON BYPRODUCTS CO., INC. NEW BRIGHTON, PA.; MIRACAPE OR MIRAFI GEOSYNTHETIC PRODUCTS, NORCROSS, GA., OR APPROVED EQUIVALENT.
9. EXECUTION:
 - A. LANDSCAPE WORK SHALL BE UNDERTAKEN AS SOON AS SITE AREAS ARE AVAILABLE.
 - B. TOPSOIL SHALL BE SPREAD NO LESS THAN 4" OVER SUB-GRADE MATERIAL. SOIL AMENDMENTS SHALL BE THOROUGHLY MIXED INTO THE TOP 4" OF TOPSOIL, FOLLOWING THE SPECIFICATIONS STATED BELOW.
 - C. PERFORM FINE GRADING TO FINISHED ELEVATION ONLY IMMEDIATELY PRIOR TO PLANTING. PLANTING AREAS SHALL BE GRADED TO A SMOOTH, EVEN SURFACE, FREE OF DEPRESSIONS OR RIDGES WITH A UNIFORM LOOSE, FINE TEXTURE.
 - D. FERTILIZING:
 - i. THE SOIL SHALL BE TESTED FOR PH AND LIME ADDED AS NECESSARY. ALL AMENDMENTS SHALL BE CHECKED AND APPROVED BY LANDSCAPE ARCHITECT BEFORE AMENDMENTS ARE MADE.
 - ii. APPLY FERTILIZER AT RATE OF 4 LBS/1000 SF FOR LAWN AREAS.
 - E. LAWN:
 - i. LAWN SEED MIX: SEED AT THE RATE OF 5 TO 6 LBS PER 1,000 SF.
 - ii. TEMPORARY COVER SEED MIX: SEED AT THE RATE OF 3 TO 4 LBS PER 1,000 SF.
 - iii. TEMPORARY COVER SEED MIX TO BE APPLIED ONLY FOR LATE FALL OR SUMMER SOIL STABILIZATION OUTSIDE ALLOWED SEEDING PERIODS.
 - F. ALL SEEDED AREAS SHALL BE PROTECTED FROM EROSION BY ONE OF THE FOLLOWING METHODS:
 - i. A UNIFORM BLANKET OF STRAW APPLIED AT A RATE OF 2 TONS/ACRE MIN. TO BE APPLIED ONCE SEEDING IS COMPLETE.
 - ii. WOOD FIBER CELLULOSE APPLIED WITH SEED MIX BY A HYDROSEEDER AT A RATE OF 2,000 LBS/ACRE.
 - G. ALL SEEDED SLOPES 3:1 OR GREATER SHALL BE PROTECTED FROM EROSION WITH JUTE MESH OR APPROVED EQUAL.
 - H. ALL NEWLY PLANTED AREAS SHALL BE KEPT MOIST BY WATERING UNTIL GRASSES AND GROUND COVERS ARE WELL ESTABLISHED. THE LANDSCAPE CONTRACTOR MUST WATER PLANT MATERIAL WHEN NECESSARY FOR 60 DAYS AFTER INSTALLATION.
 - I. LAWNS ARE TO BE WARRANTED UNTIL THEY BECOME ESTABLISHED, UNTIL FINAL ACCEPTANCE, AND NOT LESS THAN 60 DAYS AFTER COMPLETION OF ALL WORK. TREES, SHRUBS, GROUND COVERS, AND PERENNIALS SHALL BE WARRANTED AGAINST DEFECTS INCLUDING POOR GROWTH AND DEATH, EXCEPT WHEN RESULTING FROM OWNER NEGLIGENCE, INCIDENTS THAT ARE BEYOND THE CONTROL OF THE LANDSCAPE INSTALLER AND DAMAGE OR ABUSE BY OTHERS, FOR AT LEAST ONE FULL YEAR AFTER PROJECT COMPLETION.

THE SEVENTY-SIX

Parcel 76, 76 Second Avenue, City of Albany, NY

Owner: South End Development LLC

Architect: Garrison-Architects
45 Main Street
Brooklyn, NY 11201

Civil Engineer: The Chazen Companies
547 River St.
Troy, NY 12180
p (518) 273-0055
Chazen Project No. 32019.00

Revision Schedule

Revision Number	Revision Description	Revision Date

Schematic Design

Scale: AS NOTED
Date: 06/23/2020
Project No: 2005
Drawn by: KC/SM
Checked by: RK

Seal & Signature:

DOB Stamp & Signature

DOB Scan:

Drawing Title:

Landscape Details & Notes

Drawing Number:

C-507

DWG.No:

MAINTENANCE AND PROTECTION OF TRAFFIC (M&PT):

GENERAL NOTES:
 1. THE CONTRACTOR SHALL BE RESPONSIBLE FOR THE MAINTENANCE AND PROTECTION OF TRAFFIC (M&PT) FOR THE DURATION OF THE CONTRACT. M&PT SHALL BE PROVIDED IN ACCORDANCE WITH THE FOLLOWING DOCUMENTS:

- A. THE TRAFFIC CONTROL PLAN AND REQUIREMENTS SET FORTH IN THE PLANS AND/OR PROPOSAL OF THIS CONTRACT.
 - B. THE MOST CURRENT EDITION OF THE MANUAL OF UNIFORM TRAFFIC CONTROL DEVICES (MUTCD).
 - C. NEW YORK STATE DEPARTMENT OF TRANSPORTATION (NYSOT) STANDARD SPECIFICATIONS - CHAPTER 19 WORK ZONE TRAFFIC CONTROL.
 - D. NYSOT STANDARD SHEETS FOR WORK ZONE TRAFFIC CONTROL FOR LONG TERM OPERATION - 619 SERIES FOR LONG TERM OPERATIONS. I.E. THE WORK ZONE IS IN EFFECT FOR OVERNIGHT.
 - E. NYSOT WORK ZONE TRAFFIC CONTROL MANUAL FOR SHORT TERM OPERATIONS, I.E. THE WORK ZONE IS IN EFFECT ONLY DURING THE DAY AND IS NOT MAINTAINED OVERNIGHT.
2. THE MANUAL OF UNIFORM TRAFFIC CONTROL DEVICES (MUTCD) IS DEFINED AS THE NATIONAL MUTCD FOR STREETS AND HIGHWAYS (US DEPARTMENT OF TRANSPORTATION/FEDERAL HIGHWAY ADMINISTRATION) AS MODIFIED BY THE NEW YORK STATE SUPPLEMENT TO THE NATIONAL MUTCD. WHEN MUTCD IS NOTED IT REFERS TO THE MOST CURRENT EDITION.
3. THE TYPICAL DETAILS PRESENTED IN MUTCD AND NYSOT STANDARD SHEETS REFLECT MINIMUM REQUIREMENTS. ADDITIONAL DEVICES AND/OR METHODS OF TRAFFIC CONTROL MAY BE ORDERED BY THE ENGINEER TO MEET FIELD CONDITIONS.
4. PROPOSED REVISIONS TO THE TRAFFIC CONTROL PLAN MUST BE SUBMITTED FOR APPROVAL BY THE CONTRACTOR TO THE REGULATORY AGENCY WITH AUTHORITY OVER THE ROADWAY, OR ITS REPRESENTATIVE, I.E. ENGINEER. PROPOSED REVISIONS MUST BE SUBMITTED FIVE (5) WORK DAYS PRIOR TO THE PLANNED IMPLEMENTATION OF THE PROPOSED REVISIONS.
5. THE CONTRACTOR SHALL PROVIDE THE ENGINEER, IN WRITING, WITH CONTACT INFORMATION FOR STAFF AUTHORIZED TO SECURE LABOR, MATERIALS, AND EQUIPMENT FOR EMERGENCY REPAIRS OUTSIDE OF NORMAL WORK HOURS. THE CONTACT INFORMATION SHALL INCLUDE NAMES, ADDRESSES, AND TELEPHONE NUMBERS (HOME AND CELL). THE ENGINEER SHALL PROVIDE THE CONTACT INFORMATION TO THE APPROPRIATE REGULATORY AGENCIES, LOCAL POLICE AND NEW YORK STATE POLICE, AND THE LOCAL NYSOT MAINTENANCE RESIDENCY.
6. THE CONTRACTOR SHALL PROVIDE A TENTATIVE SCHEDULE OF OPERATIONS TO THE ENGINEER AND ALL LOCAL AUTHORITIES AND EMERGENCY SERVICE PROVIDERS TWO WEEKS BEFORE BEGINNING CONSTRUCTION ACTIVITIES. DURING CONSTRUCTION, THE CONTRACTOR SHALL BE REQUIRED TO PROVIDE NOTIFICATION TO THE ENGINEER, LOCAL AUTHORITIES, AND PROVIDERS OF CHANGES TO THE PREVIOUS WORK PLAN/WORK LOCATIONS. PROVISIONS SHALL BE MADE AT THE PRE-CONSTRUCTION MEETING OR OTHER MEETING PRIOR TO THE START OF WORK BETWEEN THE CONTRACTOR, LOCAL AUTHORITIES AND EMERGENCY SERVICE PROVIDERS TO ADDRESS A SITUATION WHEN EMERGENCY ACCESS IS NEEDED THROUGH A CONSTRUCTION OPERATION OF CONTRACT LIMITS.

PUBLIC ACCESS:

- 1. THE CONTRACTOR SHALL MAINTAIN AT LEAST ONE ACCESS TO EACH ADJACENT PROPERTY DURING ALL CONSTRUCTION OPERATIONS.
- 2. IF CONDITIONS REQUIRE THAT ACCESS TO A PROPERTY BE TEMPORARILY CLOSED, THE CONTRACTOR SHALL NOTIFY THE OWNER AND OCCUPANT AT LEAST 24 HOURS IN ADVANCE.
- 3. ALL PROPERTIES SHALL HAVE AT LEAST ONE ACCESS DRIVE OPEN FOR SAFE USE AT THE END OF EACH WORK DAY.
- 4. FOR MULTIPLE ACCESS PROPERTIES, AT LEAST ONE ACCESS SHALL BE OPEN AT ALL TIMES.
- 5. SUITABLE RAMPS SHALL BE INSTALLED TO MAINTAIN SMOOTH TRANSITIONS FROM RESIDENTIAL AND COMMERCIAL DRIVEWAYS TO AND FROM THE WORK AREA.

WORK LOCATIONS:

- 1. A MINIMUM 500' LONGITUDINAL DISTANCE SHALL BE MAINTAINED BETWEEN WORK OPERATIONS ON ALTERNATE SIDES OF THE ROADWAY, UNLESS OTHERWISE APPROVED BY THE ENGINEER.
- 2. IF TWO OR MORE WORK AREAS ARE ADJACENT, OVERLAP, OR IN CLOSE PROXIMITY (LESS THAN 500' APART) THE CONTRACTOR SHALL ENSURE THAT THERE ARE NO CONFLICTING SIGNS OR PAVEMENT MARKINGS, AND THAT LANE CONTINUITY IS MAINTAINED THROUGHOUT ALL WORK AREAS.

LANE CLOSURES:

- 1. THE CONTRACTOR SHALL LOCATE LANE CLOSURES TO PROVIDE OPTIMUM VISIBILITY, I.E. PRIOR TO HORIZONTAL CURVES AND VERTICAL CRESTS, TO THE EXTENT CONDITIONS PERMIT.
- 2. THE CONTRACTOR MAY BE REQUIRED TO RE-OPEN ALL TRAVEL LANES AT ANY TIME IF THE ROUTE IS NEEDED FOR EMERGENCY PURPOSES, INCLUDING INCIDENTS OUTSIDE THE CONTRACT LIMITS.
- 3. LANE CLOSURES MUST CONFORM TO THE TIME REQUIREMENTS OF THE CONTRACT DOCUMENTS AND HIGHWAY WORK ZONE PERMITS IF ISSUED.
- 4. TEMPORARY LANE CLOSURES MAY NOT BE PERMITTED DURING THE PEAK TRAVEL PERIODS OF 7:00 TO 9:00 AM AND 3:30 TO 6:00 PM UNLESS APPROVED BY THE ENGINEER.
- 5. TEMPORARY LANE CLOSURES MAY NOT BE PERMITTED DURING THE FOLLOWING HOLIDAY PERIODS: EASTER WEEKEND, MEMORIAL DAY WEEKEND, JULY 4TH, COLUMBUS DAY, THANKSGIVING, CHRISTMAS, AND NEW YEAR'S DAY.

WORK ZONE TRAVEL LANES:

- 1. THE MINIMUM LANE WIDTH FOR WORK ZONE TRAVEL LANES SHALL BE 11' FOR FREEWAYS AND/OR EXPRESSWAYS, AND 10' FOR ALL OTHER TYPES OF ROADWAYS. EXCEPTIONS TO THESE MINIMUM LANE WIDTHS MUST BE AUTHORIZED BY THE ENGINEER.
- 2. WRITTEN NOTICE SHALL BE PROVIDED BY THE CONTRACTOR TO THE ENGINEER AT LEAST 21 DAYS IN ADVANCE OF PERFORMING ANY WORK THAT RESULTS IN THE REDUCED WIDTH OF AN EXISTING ROADWAY. THE CONTRACTOR SHALL NOTIFY THE LOCAL NYSOT RESIDENCY PERMIT ENGINEER IN A TIMELY MANNER OF THE CONTRACTOR'S NOTICE.

CHANNELIZING DEVICES:

- 1. WHERE POSSIBLE ALL CHANNELIZING AND GUIDING DEVICES ARE TO BE PLACED SO AS TO PROVIDE A MINIMUM 2' LATERAL CLEARANCE TO THE TRAVELED WAY.

SIGNS:

- 1. ALL SIGNS SHALL BE LOCATED AS SHOWN IN THE WORK ZONE TRAFFIC CONTROL PLANS OR AS SPECIFIED BY THE CURRENT MUTCD, NYSOT STANDARD SHEETS, OR NYSOT WORK ZONE TRAFFIC CONTROL MANUAL. SIGNS GENERALLY SHALL BE LOCATED ALONG THE RIGHT SIDE OF THE ROADWAY FACING ONCOMING TRAFFIC AT RIGHT ANGLES.
- 2. THE LOCATIONS OF SIGNS MAY BE ADJUSTED FROM THAT SHOWN IN THE WORK ZONE TRAFFIC CONTROL PLANS BASED ON SIGHT DISTANCE AND OTHER CONSIDERATIONS. THE FINAL LOCATIONS OF SIGNS ARE SUBJECT TO THE ENGINEER'S APPROVAL.
- 3. EXISTING SIGNS THAT CONFLICT IN MESSAGE OR VISIBILITY WITH THE SIGNS REQUIRED BY THE WORK ZONE TRAFFIC CONTROL PLAN LAYOUT SHALL BE COVERED, REMOVED, STORED OR RESET AS APPROVED BY THE ENGINEER. ALL APPROPRIATE EXISTING SIGNS SHALL BE RESTORED TO THEIR ORIGINAL CONDITION AND/OR LOCATION UNLESS REPLACED UNDER THIS CONTRACT.
- 4. SIGNS AT OR NEAR INTERSECTIONS SHALL BE PLACED SO THAT THEY DO NOT OBSTRUCT A MOTORIST'S LINE OF SIGHT.
- 5. WARNING AND REGULATORY SIGNS SHALL BE POSTED ON BOTH SIDES OF MULTI-LANE DIVIDED HIGHWAYS, MULTI-LANE RAMPS, AND ONE WAY STREETS. IF LANE RESTRICTIONS REDUCE THE TRAVEL WAY TO ONE LANE, SIGNS SHALL BE PLACED ON THE RIGHT SIDE OF THE ACTIVE TRAVEL LANE, UNLESS OTHERWISE AUTHORIZED BY THE ENGINEER.
- 6. THE DIMENSIONS OF WORK ZONE TRAFFIC CONTROL SIGNS ARE DESCRIBED IN THE MUTCD AND OTHER DOCUMENTS NOTED IN "GENERAL NOTES 1". ANY CHANGES TO THE DIMENSIONS SHALL BE APPROVED BY THE ENGINEER.
- 7. SIGN INSTALLATION NOTES:
 - A. SIGN SUPPORT - THE CONTRACTOR SHALL SUFFICIENTLY SUPPORT SIGNS SO THAT THE SIGNS ARE IMPROPER POSITION AND ALIGNMENT AS SHOWN IN THE WORK ZONE TRAFFIC CONTROL PLAN, AND OTHER M&PT REQUIREMENT DOCUMENTATION. ALL WOOD SUPPORTS SHALL BE PAINTED WITH TWO (2) COATS OF WHITE PAINT.
 - B. SIGN PANELS MAY BE MADE OF ALUMINUM SHEET OR PLYWOOD. THE BACKS OF ALL PLYWOOD PANELS SHALL BE PAINTED WITH TWO (2) COATS OF WHITE PAINT.
 - C. SIGN LEGEND - SIGN LEGEND, BORDERS AND MARGINS SHALL BE IN ACCORDANCE WITH THE MUTCD.
 - D. SIGN COLOR - THE COLOR OF THE SIGN BACKGROUND AND LEGEND SHALL BE AS SPECIFIED IN THE MUTCD. THE MARGIN SHALL BE THE SAME COLOR SPECIFIED FOR THE BACKGROUND, AND THE BORDER SHALL BE THE SAME COLOR SPECIFIED FOR THE LEGEND.
 - E. SIGN SHAPE - THE SHAPE OF ALL SIGNS SHALL BE AS SPECIFIED IN THE MUTCD. CORNERS OF SIGNS SHALL BE ROUNDED.
 - F. REFLECTORIZATION - ALL SIGNS SHALL BE REFLECTIVE USING HIGH INTENSITY REFLECTORIZED TACHYON PANTS. ALL SIGNS SHALL BE REVIEWED AT NIGHT AFTER ERECTION FOR VISIBILITY AND REFLECTORIZATION. ANY SIGNS NOT MEETING PROPER REFLECTION REQUIREMENTS SHALL BE REPLACED.
- 8. THE CONTRACTOR SHALL KEEP SIGNS CLEANED AND CLEARED AT ALL TIMES. ALL SIGNS ARE THE PROPERTY OF THE CONTRACTOR AND SHALL BE MAINTAINED IN GOOD CONDITION FOR THE DURATION OF THE CONTRACT. ALL SIGNS SHALL BE REMOVED FROM THE WORK SITE WHEN THE CONTRACT WORK IS ACCEPTED.

PAVEMENT MARKINGS:

- 1. ALL TEMPORARY PAVEMENT MARKINGS SHALL BE PLACED (LOCATED) IN ACCORDANCE WITH THE CONTRACT DOCUMENTS AND THE MUTCD.
- 2. ALL TEMPORARY PAVEMENT MARKINGS SHALL CONFORM TO THE MATERIAL AND PLACEMENT REQUIREMENTS OF THE CONTRACT DOCUMENTS, MUTCD, AND NYSOT STANDARD SPECIFICATIONS.
- 3. IF REQUIRED TEMPORARY PAVEMENT MARKINGS CONFLICT IN MESSAGE OR LOCATION WITH EXISTING PAVEMENT MARKINGS, THE EXISTING PAVEMENT MARKINGS WILL BE REMOVED OR COVERED FOR THE DURATION OF THE USE OF THE TEMPORARY MARKINGS AS APPROVED BY THE ENGINEER. ALL APPROPRIATE EXISTING MARKINGS SHALL BE RESTORED TO THEIR ORIGINAL CONDITION AND/OR LOCATION UNLESS REPLACED UNDER THIS CONTRACT.

TEMPORARY TRAFFIC SIGNALS:

- 1. THE OPERATION, I.E. PHASING AND TIMING, OF TEMPORARY TRAFFIC SIGNALS OR EXISTING TRAFFIC SIGNAL MODIFIED TO CONTROL WORK ZONE ACTIVITY, SHALL BE APPROVED BY THE REGULATORY AUTHORITY HAVING CONTROL OVER THE ROADWAY AND/OR EXISTING TRAFFIC SIGNAL.
- 2. TEMPORARY TRAFFIC SIGNALS INSTALLED FOR WORK ZONE ACTIVITIES SHALL CONFORM TO THE REQUIREMENTS OF THE MUTCD AND NYSOT STANDARD SHEET 619-62, EFFECTIVE DATE 01/08/09.
- 3. ALL WORK ZONE OPERATIONS AND WORK SHALL BE COMPLETED AND ACCEPTED BY THE ENGINEER PRIOR TO THE REMOVAL OF THE TEMPORARY TRAFFIC SIGNAL(S) INSTALLED TO CONTROL TRAFFIC FOR THOSE ACTIVITIES.
- 4. THE CONTRACTOR SHALL PROVIDE THE ENGINEER, IN WRITING, WITH CONTACT INFORMATION FOR STAFF AUTHORIZED TO PERFORM MAINTENANCE AND REPAIRS TO TEMPORARY TRAFFIC SIGNALS DURING AND OUTSIDE OF NORMAL WORK HOURS. THE CONTACT INFORMATION SHALL INCLUDE NAMES, ADDRESSES, AND TELEPHONE NUMBERS (HOME AND CELL). THE ENGINEER SHALL PROVIDE THE CONTACT INFORMATION TO THE APPROPRIATE REGULATORY AGENCIES, LOCAL POLICE, AND NEW YORK STATE POLICE.

WORK DURATION

WORK DURATION DIRECTLY INFLUENCES THE REQUIREMENTS FOR WORK ZONE TRAFFIC CONTROL TO FACILITATE THE UNDERSTANDING OF THE INFORMATION PRESENTED IN THE CONTRACT PLANS AND DOCUMENTS, ESPECIALLY THE NYSOT DOCUMENTS REFERENCED IN THE M&PT GENERAL NOTES. THE FOLLOWING DEFINITIONS ARE PRESENTED.

- 1. LONG TERM STATIONARY WORK - WORK THAT OCCUPIES A LOCATION MORE THAN THREE CONSECUTIVE DAYS. TYPICALLY THE WORK AREA IS OCCUPIED BY EXCAVATIONS, MATERIALS, AND/OR EQUIPMENT AT TIMES WHEN WORKERS ARE NOT PRESENT.
- 2. INTERMEDIATE-TERM STATIONARY WORK - WORK THAT OCCUPIES A LOCATION MORE THAN ONE DAYLIGHT PERIOD UP TO THREE CONSECUTIVE DAYS, OR NIGHTTIME WORK LASTING MORE THAN ONE HOUR. TYPICALLY THE WORK AREA IS OCCUPIED BY EXCAVATIONS, MATERIALS, AND/OR EQUIPMENT AT TIMES WHEN WORKERS ARE NOT PRESENT.
- 3. SHORT-TERM STATIONARY WORK - DAYTIME WORK THAT OCCUPIES A LOCATION FOR MORE THAN ONE HOUR WITHIN A SINGLE DAYLIGHT PERIOD. EXAMPLES ARE GUIDERAIL REPAIR, DITCH MAINTENANCE, AND BRIDGE INSPECTION.
- 4. SHORT DURATION WORK - WORK THAT OCCUPIES A LOCATION UP TO ONE HOUR. EXAMPLES ARE POT HOLE REPAIR, MINOR GUIDERAIL REPAIR, AND SIGN REPAIR.
- 5. MOBILE WORK - WORK THAT MOVES INTERMITTENTLY OR CONTINUOUSLY. EXAMPLES ARE PAINT STRIPING OPERATIONS, SWEEPING OPERATIONS, AND HERBICIDE SPRAYING.

THE ABOVE DEFINITIONS ARE ON PER NYSOT STANDARD SHEET 619-11, EFFECTIVE DATE 01/08/09, AND THE NYSOT WORK ZONE TRAFFIC CONTROL MANUAL.

LONG-TERM AND INTERMEDIATE-TERM WORK ZONE TRAFFIC CONTROL REQUIREMENTS ARE COVERED BY THE 619 SERIES OF THE NYSOT STANDARD SHEETS.

SHORT-TERM, SHORT DURATION, AND MOBILE WORK ZONE TRAFFIC CONTROL REQUIREMENTS ARE COVERED BY THE NYSOT WORK ZONE TRAFFIC CONTROL MANUAL.

CLOSURE TYPE	EXPOSURE CONDITION ¹	USE REQUIREMENTS ^{4,5}			
		FREEWAY	NON-FREEWAY (PRECONSTRUCTION POSTED SPEED LIMIT) ≤ 45 MPH	35-40 MPH	30 MPH
LANE CLOSURE	WORKERS ON FOOT OR IN VEHICLES EXPOSED TO TRAFFIC	REQUIRED ³	REQUIRED ³	REQUIRED ³	OPTIONAL ²
	NON-TRANSVERSABLE HAZARD (I.E. EQUIPMENT, MATERIALS, EXCAVATION) ONLY NO WORKERS EXPOSED	REQUIRED ³	REQUIRED ³	OPTIONAL ²	OPTIONAL ²
SHOULDER CLOSURE	WORKERS ON FOOT OR IN VEHICLES EXPOSED TO TRAFFIC	REQUIRED ³	REQUIRED ³	OPTIONAL ²	OPTIONAL ²
	NON-TRANSVERSABLE HAZARD (I.E. EQUIPMENT, MATERIALS, EXCAVATION) ONLY NO WORKERS EXPOSED	REQUIRED ³	OPTIONAL ²	OPTIONAL ²	OPTIONAL ²

- 1. THE EXPOSURE CONDITIONS DESCRIBED IN TABLE NY1-A ASSUMES THERE IS NO POSITIVE PROTECTION (TEMPORARY TRAFFIC BARRIER) PRESENT. WHERE WORKERS OR HAZARDS ARE PROTECTED BY A TEMPORARY TRAFFIC BARRIER, BARRIER VEHICLES ARE NOT REQUIRED.
- 2. WHERE THE REQUIREMENT IS "OPTIONAL", EITHER A BARRIER VEHICLE OR THE STANDARD LONGITUDINAL BUFFER SPACE (TABLE 6C-2) SHALL BE PROVIDED.
- 3. REQUIREMENTS SHALL INCLUDE PROVIDING A SEPARATE BARRIER VEHICLE FOR EACH CLOSED LANE AND EACH CLOSED PAVED SHOULDER 8' OR GREATER IN WIDTH. IF THE WORK SPACE MOVES WITH IN THE STATIONARY CLOSURE, THE BARRIER VEHICLE SHALL BE REPOSITIONED ACCORDINGLY.
- 4. BARRIER VEHICLES PROTECTING NON-TRANSVERSABLE HAZARDS SHALL REMAIN IN PLACE DURING BOTH WORKING AND NON-WORKING HOURS UNTIL THE HAZARD NO LONGER EXISTS. EXCEPTIONS TO THESE REQUIREMENTS MAY BE MADE, AS APPROVED BY THE REGIONAL DIRECTOR OR HIS/HER DESIGN EE WHERE BARRIER VEHICLE PLACEMENT WOULD BE INEFFECTIVE OR WOULD INTERFERE WITH THE SAFE OPERATION OF TRAFFIC.
- 5. BARRIER VEHICLES ARE NOT REQUIRED FOR MILLING AND/OR PAVING OPERATIONS, BUT THE STANDARD LONGITUDINAL BUFFER SPACE (TABLE 6C-2) SHALL BE PROVIDED. BARRIER VEHICLES ARE NOT REQUIRED FOR FLAGGING OPERATIONS, BUT THE STANDARD LONGITUDINAL BUFFER SPACE (TABLE 6C-2) SHALL BE PROVIDED.

ROAD TYPE	ADVANCE WARNING SIGN SPACING					TAPER LENGTH FOR TEMPORARY TRAFFIC CONTROL ZONES	
	A (FT.)	B (FT.)	C (FT.)	XX	YY	TYPE OF TAPER	TAPER LENGTH (L)
URBAN (1 30 MPH)	100	100	100	AHEAD	AHEAD	SHIFTING TAPER	L/2
URBAN (35-40 MPH)	200	200	200	AHEAD	AHEAD	SHOULDER TAPER	L/3
URBAN (45 MPH)	350	350	350	1000 FT.	AHEAD	ONE-LANE, TWO-WAY TRAFFIC TAPER	100 FT. MAXIMUM
RURAL	500	500	500	1000 FT.	1000 FT.	DOWNSTEAM TAPER	100 FT. PER LANE
EXPRESSWAY / FREEWAY	1000	1500	2840	1 MILE	1/2 MILE		

URBAN: (MEETS MORE THAN 1 OF THE FOLLOWING CRITERIA) SIDEWALKS, BICYCLE USAGE, CURBING, CLOSED DRAINAGE SYSTEMS, DRIVEWAY DENSITIES GREATER THAN 24 DRIVEWAYS PER MILE, MINOR COMMERCIAL DRIVEWAY DENSITIES OF 10 DRIVEWAYS PER MILE OR GREATER, MAJOR COMMERCIAL DRIVEWAYS, NUMEROUS RIGHT OF WAY CONSTRAINTS, HIGH DENSITY OF GROSS STREETS, 85TH PERCENTILE SPEEDS OF 45 MPH OR LESS.	PLACEMENT DISTANCE (FT.) BARRIER VEHICLES*			
	PRECONSTRUCTION POSTED SPEED LIMIT (MPH)	MINIMUM (18000 LBS.)	MINIMUM (24000 LBS.)	MAXIMUM
> 55	100 FT.	200 FT.	100 FT.	200 FT.
45 - 55	100 FT.	200 FT.	85 FT.	165 FT.
< 45	85 FT.	165 FT.	50 FT.	100 FT.
RURAL: (ANY AREA NOT EXHIBITING MORE THAN ONE OF THE ABOVE CHARACTERISTICS)	50	425 FT.	55	495 FT.
60	570 FT.	65	645 FT.	

* AS DEFINED IN NYSOT STANDARD SPECIFICATION 619-
 BARRIER VEHICLE - VEHICLE USED FOR STATIONARY SHOULDER CLOSURES, LANE CLOSURES, AND OTHER STATIONARY WORK ZONES.
 MINIMUM DISTANCE SHOWN REFLECTS THE ACTUAL ROLL AHEAD DISTANCE FROM MANUFACTURER.

EXPRESSWAY: DIVIDED HIGHWAYS FOR TRAFFIC WITH FULL OR PARTIAL CONTROL OF ACCESS AND GENERALLY WITH GRADE SEPARATION SAT MAJOR CROSSROADS.
 FREEWAYS/INTERSTATE: LOCAL OR INTER REGIONAL HIGHWAYS, DIVIDED-HIGH-VOLUME FACILITIES WITH FULL OR PARTIAL CONTROL OF ACCESS.

SPEED LIMIT (S) (MPH)	TAPER LENGTH (L) (FT.)
(40 MPH) OR LESS	$L = W^2 / 60$
(45 MPH) OR MORE	$L = WS$

LATERAL SHIFT OF TRAFFIC FLOW PATH	TEMPORARY TRAFFIC CONTROL ZONE POSTED SPEED LIMIT									
	(25 MPH)	(30 MPH)	(35 MPH)	(40 MPH)	(45 MPH)	(50 MPH)	(55 MPH)	(60 MPH)	(65 MPH)	(70 MPH)
4	45	60	85	110	180	200	220	240	260	280
5	55	75	105	135	225	250	275	300	325	350
6	65	90	125	160	270	300	330	360	390	420
7	75	105	145	190	315	350	385	420	455	490
8	85	120	165	215	360	400	440	480	520	560
9	95	135	185	240	405	450	495	540	585	630
10	105	150	205	270	450	500	550	600	650	700
11	115	165	225	295	495	550	605	660	715	770
12	125	180	245	320	540	600	660	720	780	840

IF WARRANTED CONTRACTOR CAN SUBMIT ALTERNATE M&PT PLANS TO FACILITATE CONSTRUCTION ACTIVITIES TO THE CITY & THE ENGINEER FOR REVIEW & APPROVAL PRIOR TO START OF CONSTRUCTION.

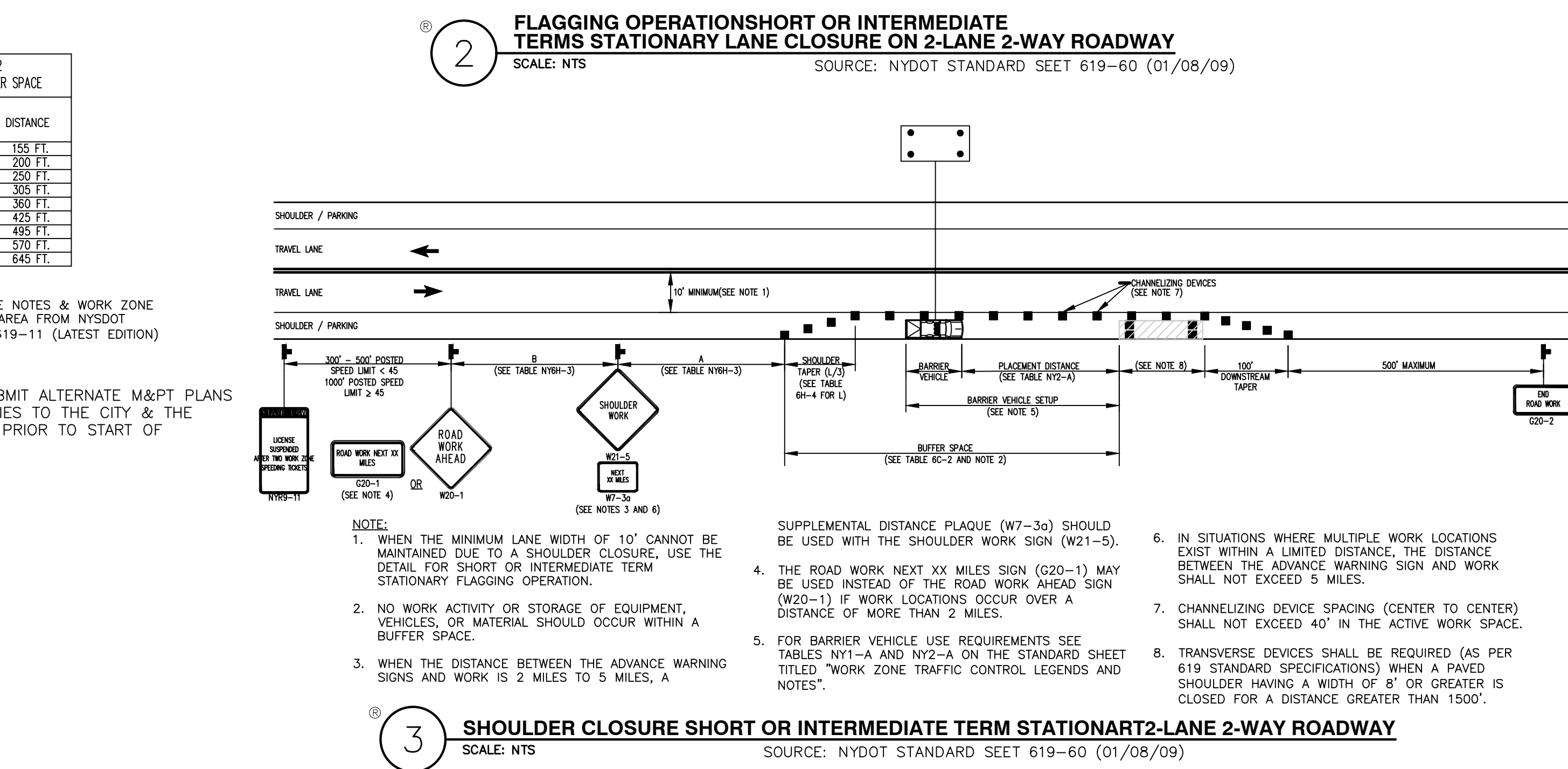
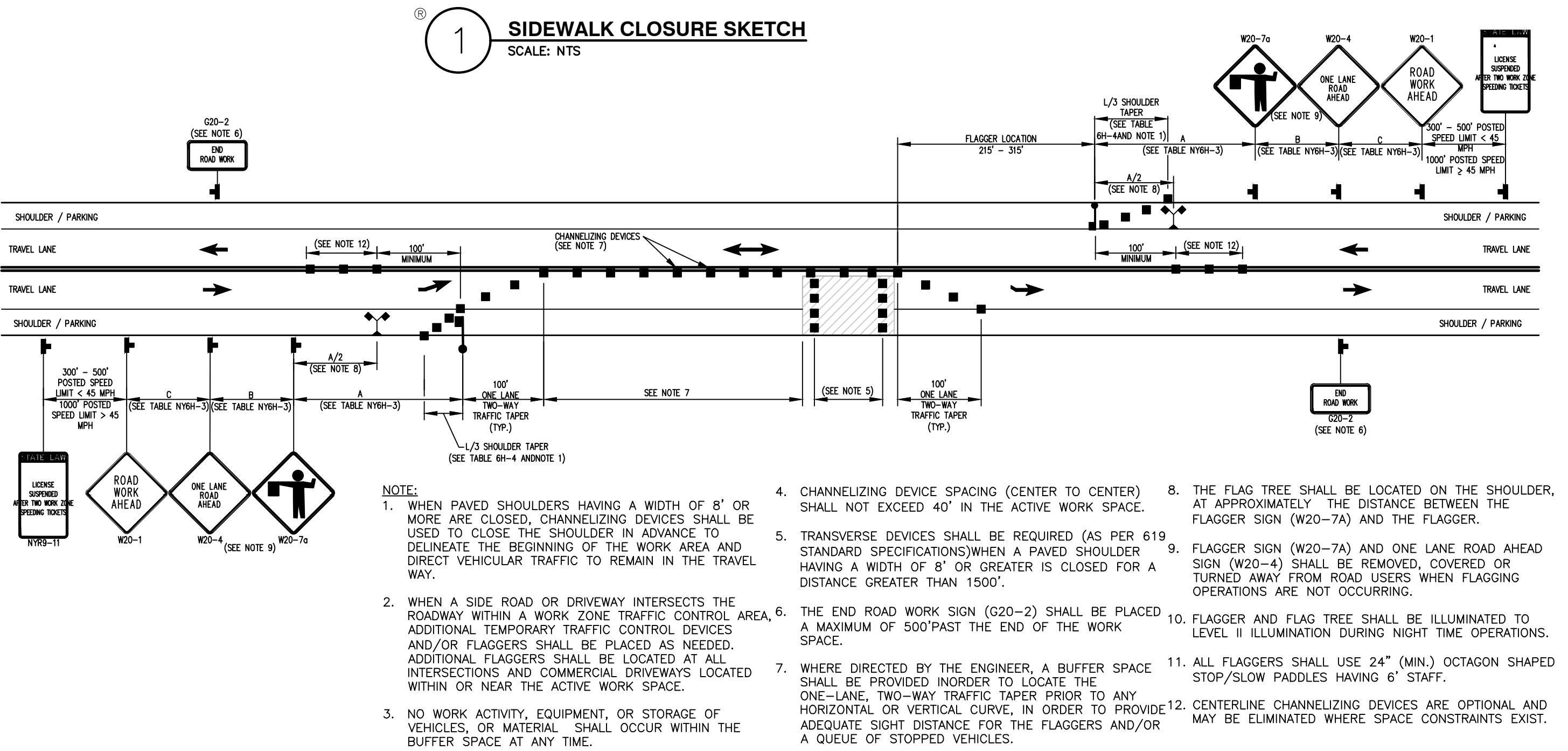
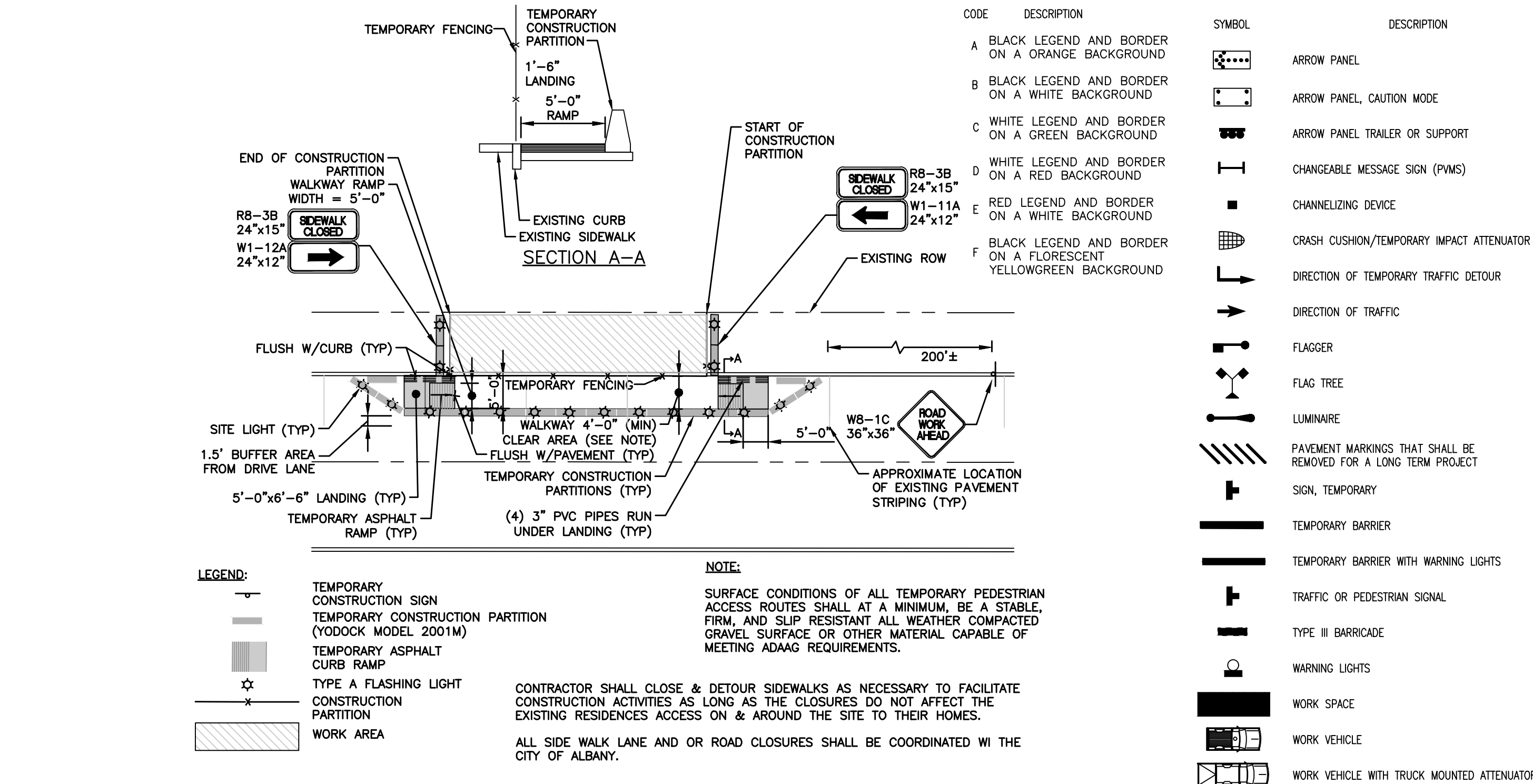

SIGNAGE COLOR CODE LEGEND

CODE	DESCRIPTION
A	BLACK LEGEND AND BORDER ON AN ORANGE BACKGROUND
B	BLACK LEGEND AND BORDER ON A WHITE BACKGROUND
C	WHITE LEGEND AND BORDER ON A GREEN BACKGROUND
D	WHITE LEGEND AND BORDER ON A RED BACKGROUND
E	RED LEGEND AND BORDER ON A WHITE BACKGROUND
F	BLACK LEGEND AND BORDER ON A FLORESCENT YELLOWGREEN BACKGROUND

WORK ZONE TRAFFIC CONTROL LEGEND

SYMBOL	DESCRIPTION
ARROW PANEL	ARROW PANEL
ARROW PANEL, CAUTION MODE	ARROW PANEL, CAUTION MODE
ARROW PANEL TRAILER OR SUPPORT	ARROW PANEL TRAILER OR SUPPORT
CHANGEABLE MESSAGE SIGN (PMS)	CHANGEABLE MESSAGE SIGN (PMS)
CHANNELIZING DEVICE	CHANNELIZING DEVICE
CRASH CUSHION/TEMPORARY IMPACT ATTENUATOR	CRASH CUSHION/TEMPORARY IMPACT ATTENUATOR
DIRECTION OF TEMPORARY TRAFFIC DETOUR	DIRECTION OF TEMPORARY TRAFFIC DETOUR
DIRECTION OF TRAFFIC	DIRECTION OF TRAFFIC
FLAGGER	FLAGGER
FLAG TREE	FLAG TREE
LUMINAIRE	LUMINAIRE
PAVEMENT MARKINGS THAT SHALL BE REMOVED FOR A LONG TERM PROJECT	PAVEMENT MARKINGS THAT SHALL BE REMOVED FOR A LONG TERM PROJECT
SIGN, TEMPORARY	SIGN, TEMPORARY
TEMPORARY BARRIER	TEMPORARY BARRIER
TEMPORARY BARRIER WITH WARNING LIGHTS	TEMPORARY BARRIER WITH WARNING LIGHTS
TRAFFIC OR PEDESTRIAN SIGNAL	TRAFFIC OR PEDESTRIAN SIGNAL
TYPE III BARRICADE	TYPE III BARRICADE
WARNING LIGHTS	WARNING LIGHTS
WORK SPACE	WORK SPACE
WORK VEHICLE	WORK VEHICLE
WORK VEHICLE WITH TRUCK MOUNTED ATTENUATOR	WORK VEHICLE WITH TRUCK MOUNTED ATTENUATOR

THE SEVENTY-SIX

Parcel 76, 76 Second Avenue, City of Albany, NY

Owner: South End Development LLC

Architect: Garrison-Architects
 45 Main Street
 Brooklyn, NY 11201

Civil Engineer: The Chazen Companies
 547 River St.
 Troy, NY 12180
 p (518) 273-0055
 Construction Project No. 32019.00

Revision Schedule

Revision Number	Revision Description	Revision Date

Schematic Design

Scale: AS NOTED
 Date: 06/23/2020
 Project No: 2005
 Drawn by: KC/SM
 Checked by: RK

Seal & Signature:

DOB Stamp & Signature

DOB Scan:

Work Zone Traffic Control Details & Notes

Drawing Number:

C-508

DWG.No:

The Seventy-Six

Parcel 76, 76 Second Avenue, City of Albany, NY

Owner: South End Development LLC

Architect:
Garrison-Architects
45 Main Street
Brooklyn, NY 11201

Revision Schedule		
Revision Number	Revision Description	Revision Date

SCHEMATIC DESIGN

Scale: AS NOTED
Date: 6/22/2020
Project No: 2005
Drawn by:
Checked by:

Seal & Signature:

DOB Stamp & Signature

DOB Scan:

Drawing Title:
Overall Floor Plans

Drawing Number:
AA-101

DWG.No: of

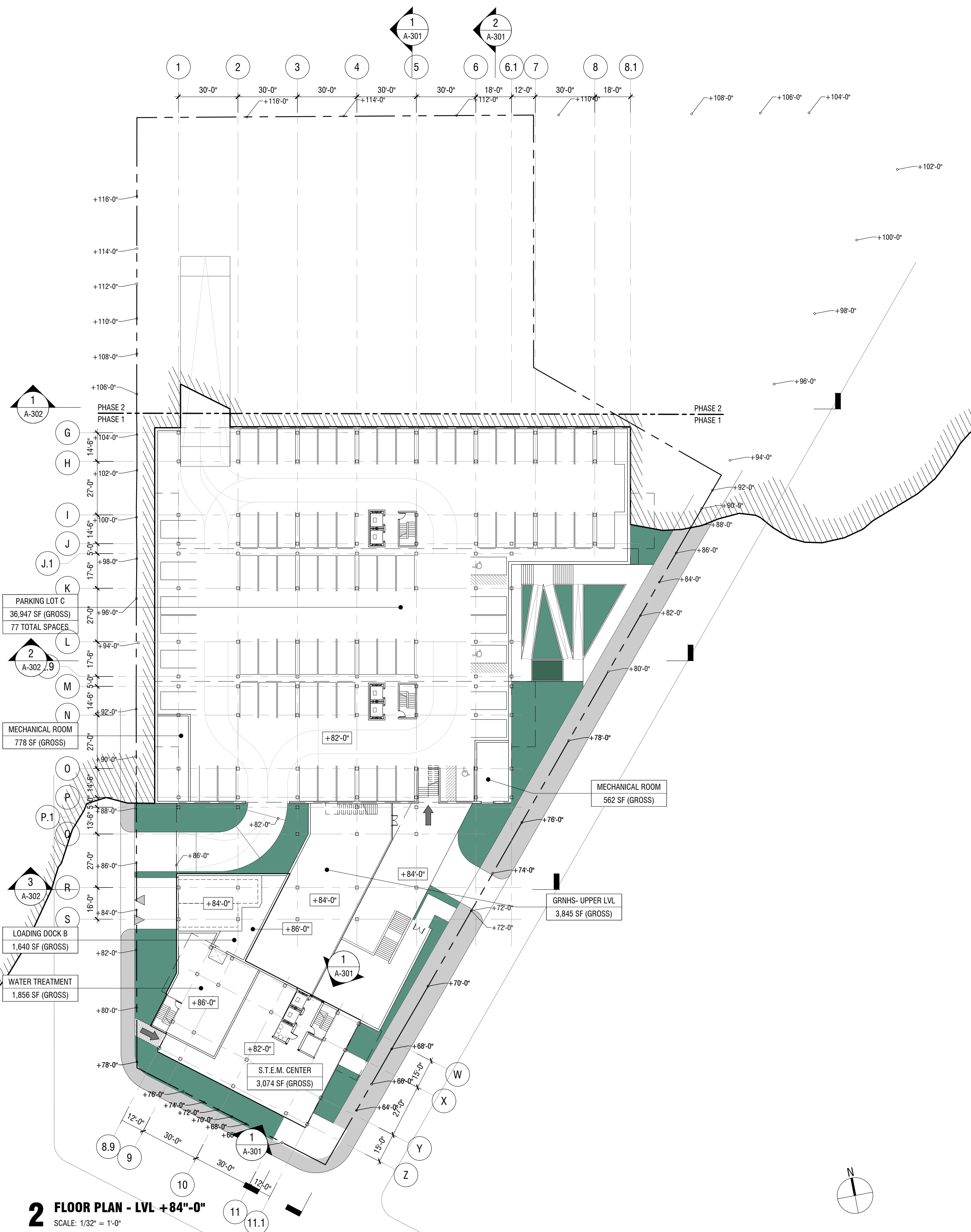

The Seventy-Six

Parcel 76, 76 Second Avenue, City of Albany, NY

Owner: South End Development LLC

Architect: Garrison-Architects
45 Main Street
Brooklyn, NY 11201

Revision Schedule		
Revision Number	Revision Description	Revision Date

SCHEMATIC DESIGN

Scale: AS NOTED
Date: 6/22/2020
Project No: 2005
Drawn by:
Checked by:

Seal & Signature:

DOB Stamp & Signature

DOB Scan:

Drawing Title:
Overall Floor Plans

Drawing Number:
AA-102

DWG.No: of

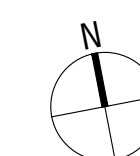
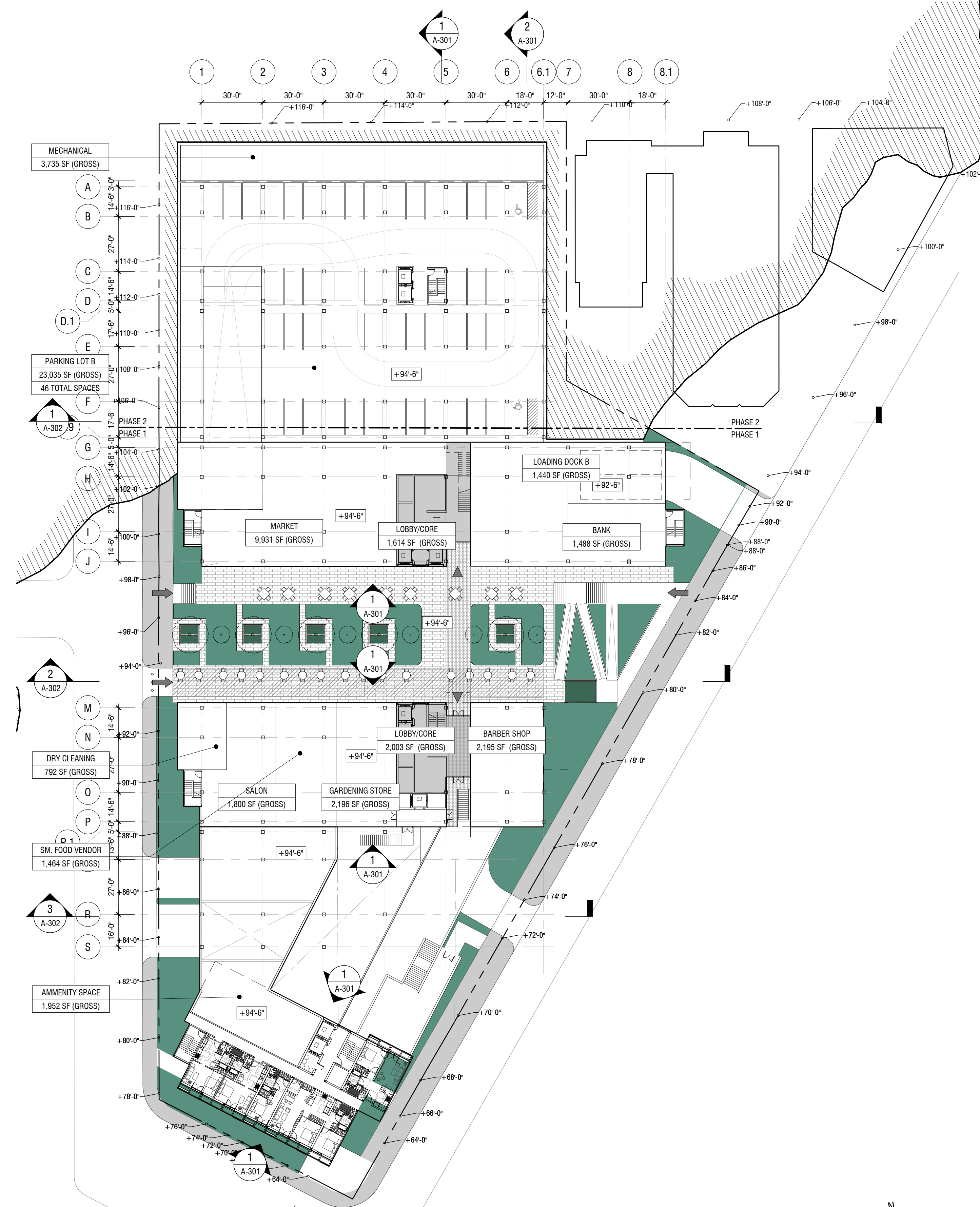

The Seventy-Six

Parcel 76, 76 Second Avenue, City of Albany, NY

Owner: South End Development LLC

Architect:
Garrison-Architects
45 Main Street
Brooklyn, NY 11201

Revision Schedule		
Revision Number	Revision Description	Revision Date

SCHEMATIC DESIGN

Scale: AS NOTED
Date: 6/22/2020
Project No: 2005
Drawn by:
Checked by:

Seal & Signature:

DOB Stamp & Signature

DOB Scan:

Drawing Title:
Overall Floor Plans

Drawing Number:
AA-103

DWG.No: of

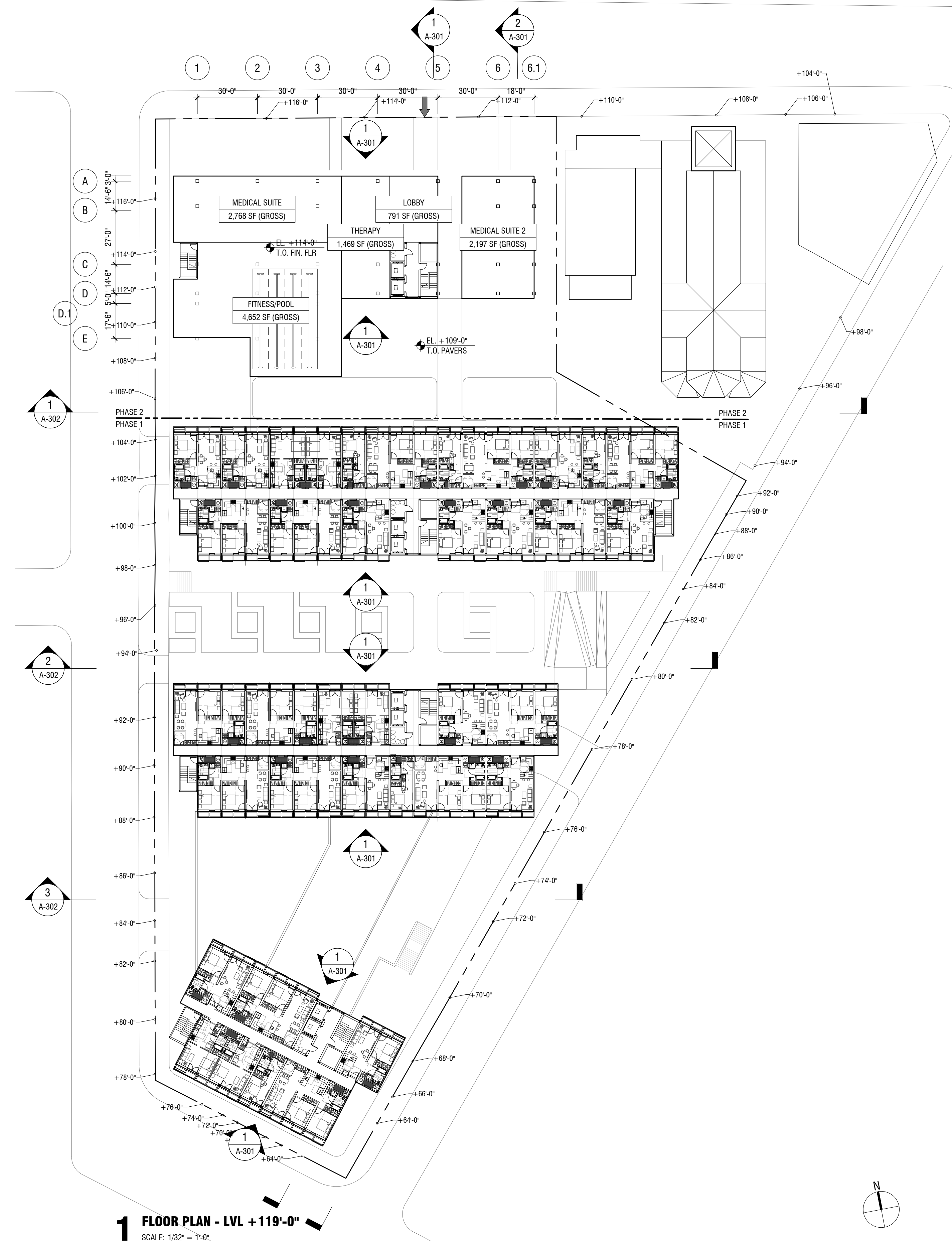
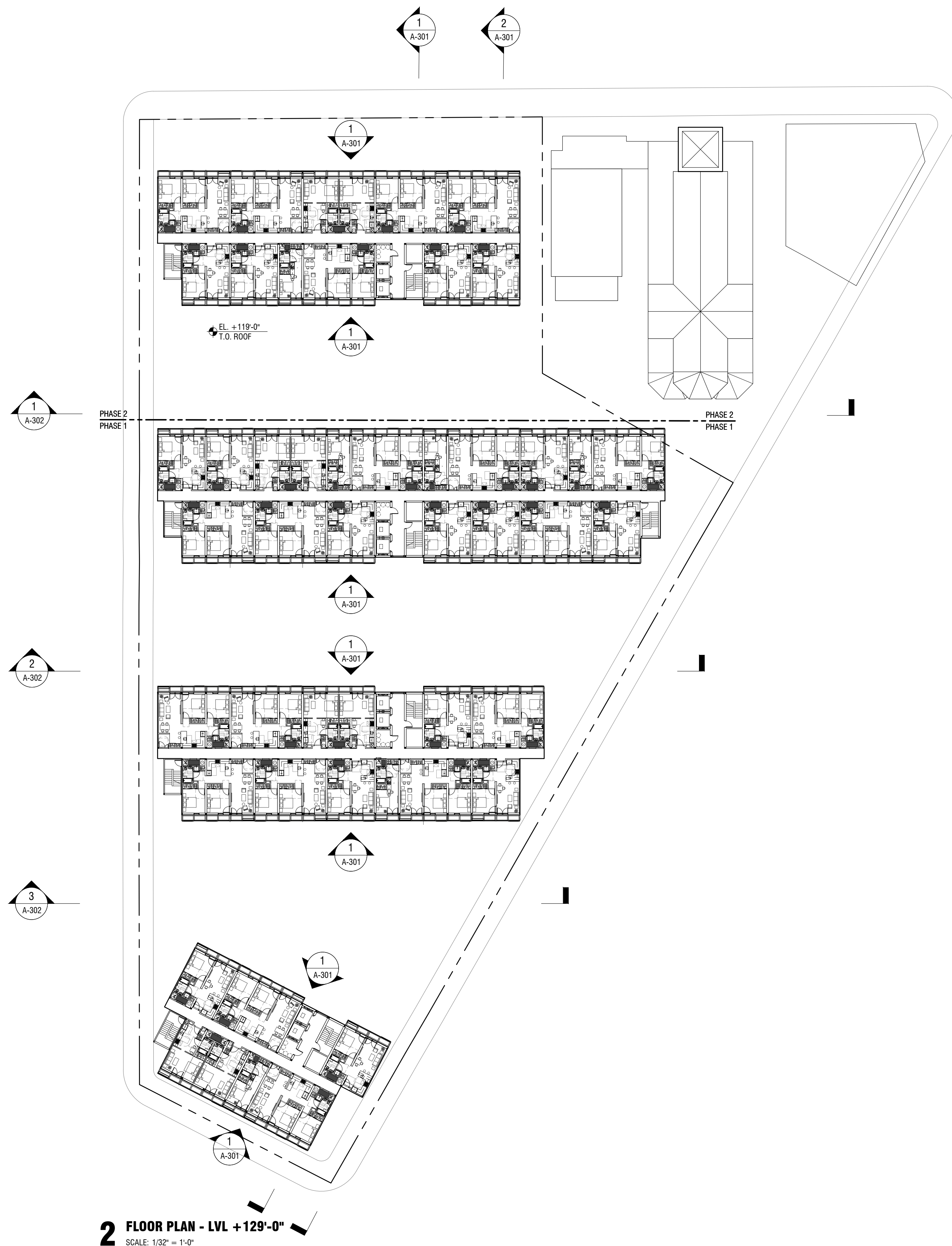

The Seventy-Six

Parcel 76, 76 Second Avenue, City of Albany, NY

Owner: South End Development LLC

Architect:
Garrison-Architects
45 Main Street
Brooklyn, NY 11201

Revision Number	Revision Description	Revision Date

SCHEMATIC DESIGN

Scale: AS NOTED
Date: 6/22/2020
Project No: 2005
Drawn by:
Checked by:

Seal & Signature:

DOB Stamp & Signature

DOB Scan:

Drawing Title:
Overall Floor Plans

Drawing Number:
AA-105

DWG.No: of

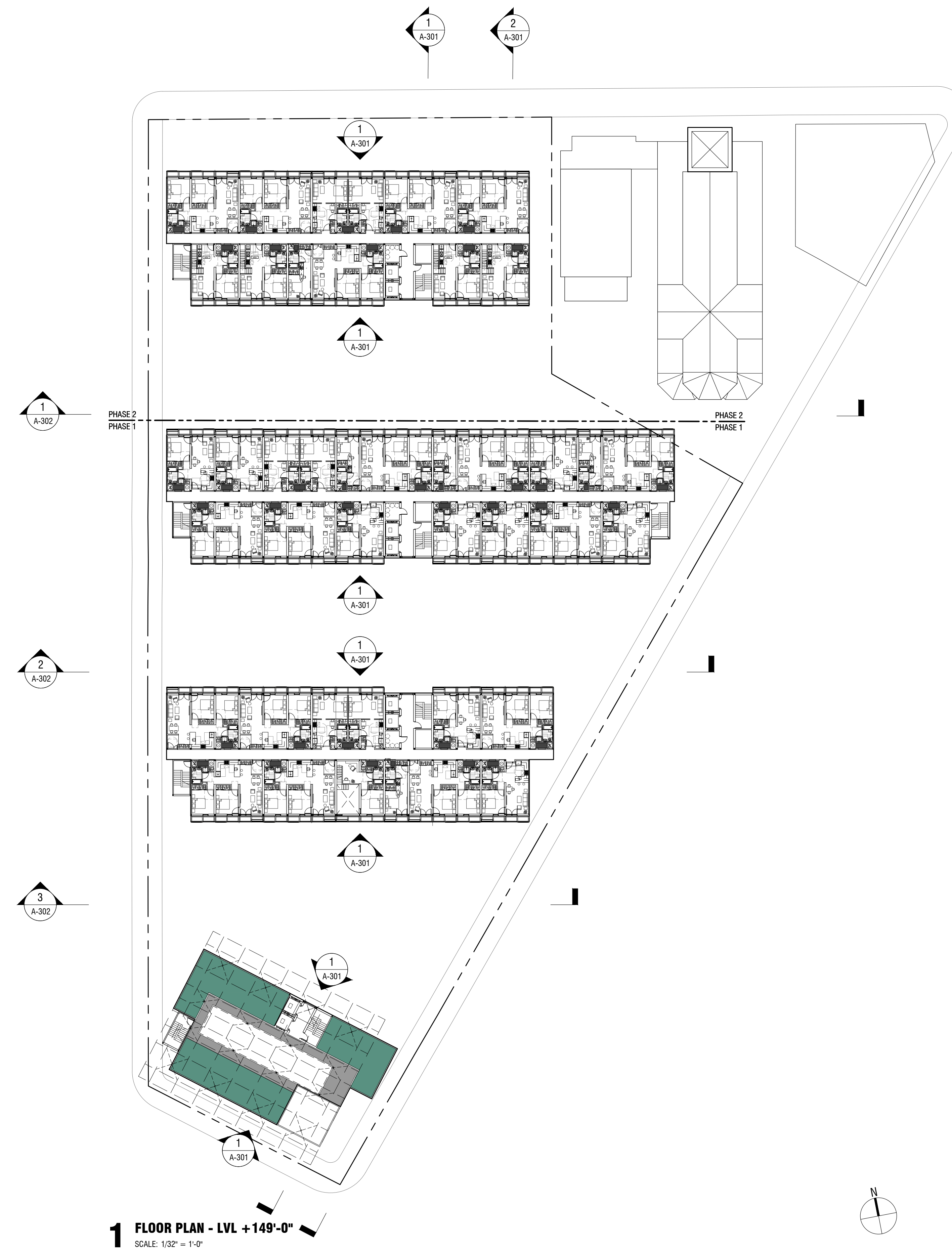
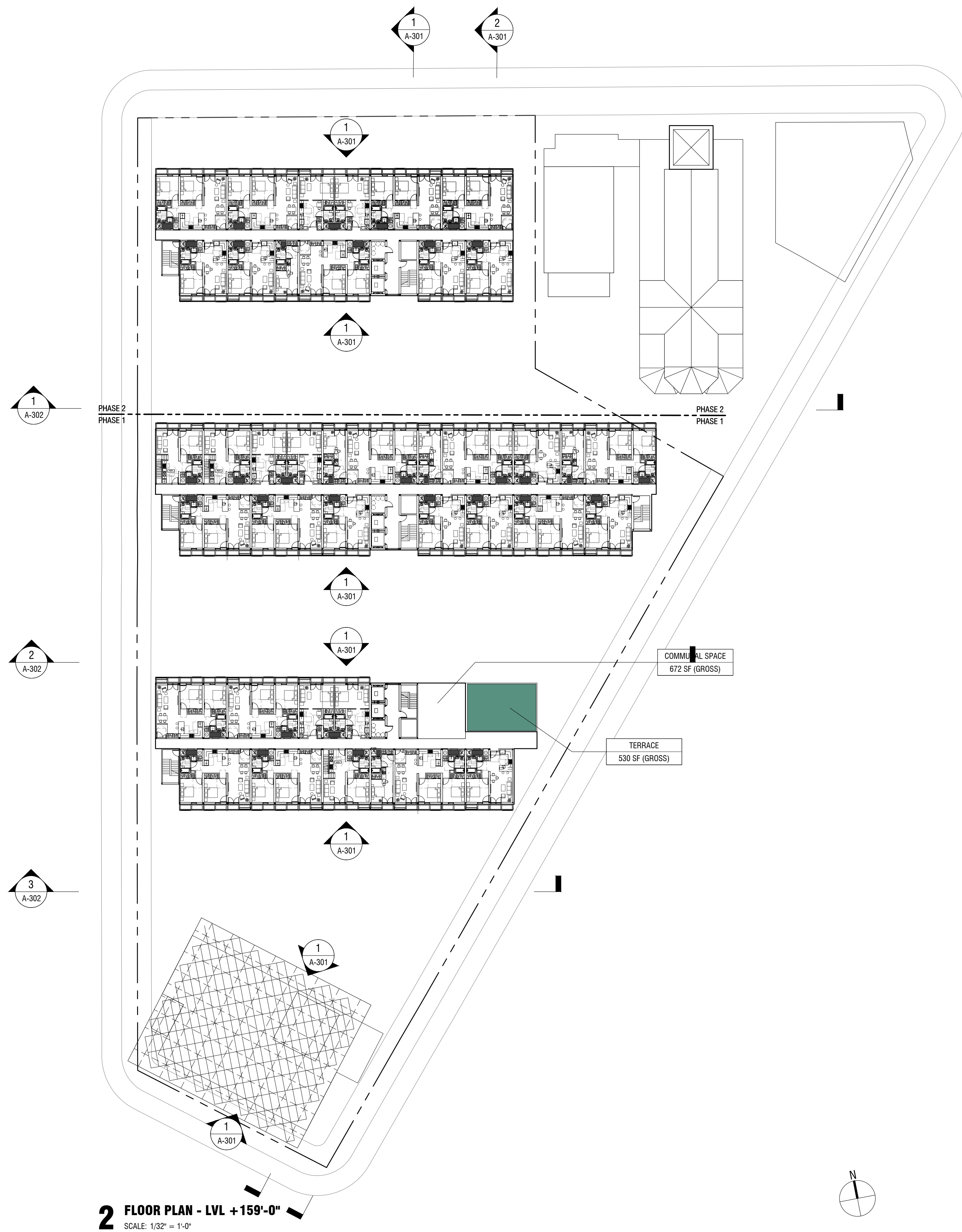

The Seventy-Six

Parcel 76, 76 Second Avenue, City of Albany, NY

Owner: South End Development LLC

Architect:
Garrison-Architects
45 Main Street
Brooklyn, NY 11201

Revision Schedule		
Revision Number	Revision Description	Revision Date

SCHEMATIC DESIGN

Scale: AS NOTED
Date: 6/22/2020
Project No: 2005
Drawn by:
Checked by:

Seal & Signature:

DOB Stamp & Signature

DOB Scan:

Drawing Title:
Overall Floor Plans

Drawing Number:
AA-106

DWG.No: of

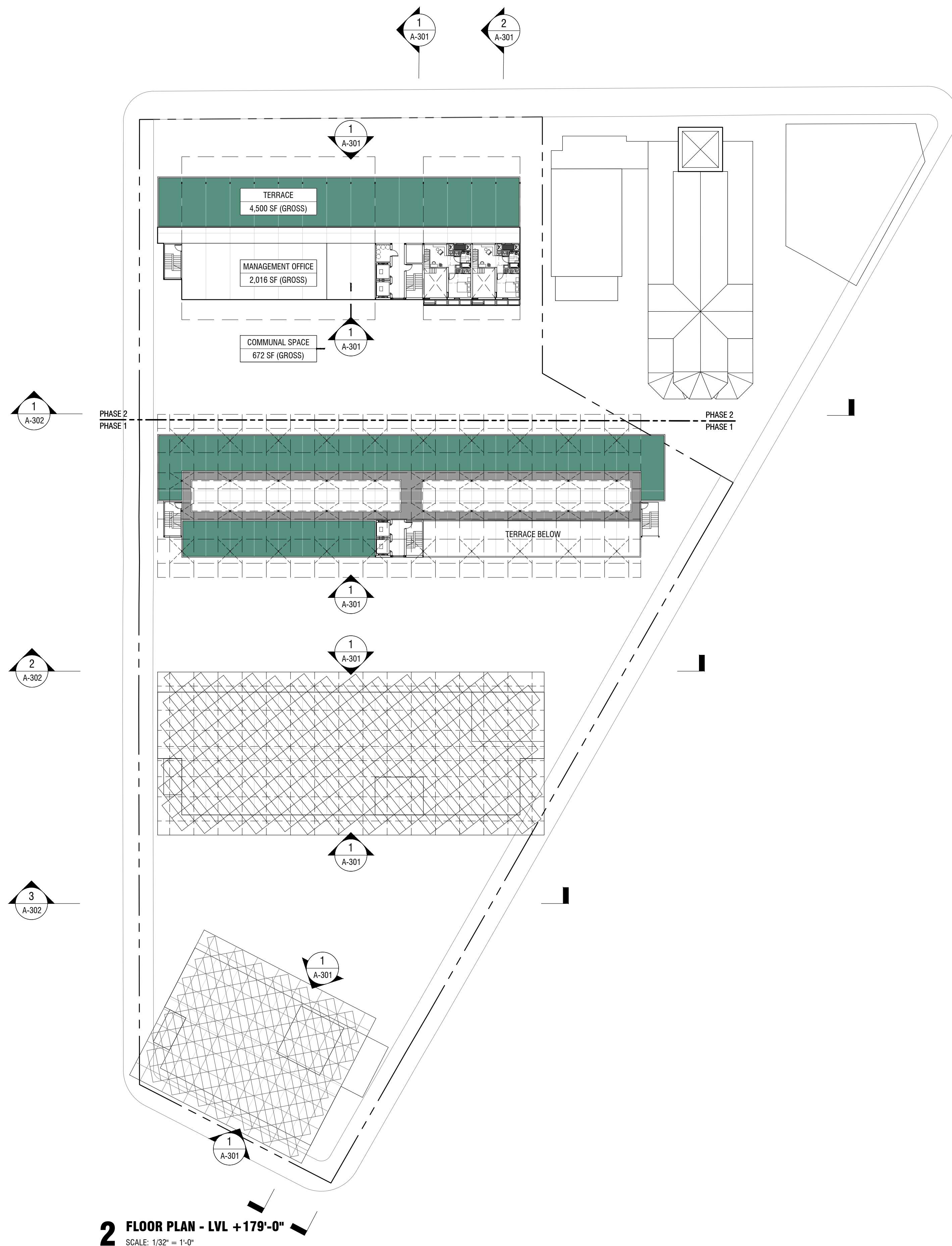

The Seventy-Six

Parcel 76, 76 Second Avenue, City of Albany, NY

Owner: South End Development LLC

Architect:
Garrison-Architects
45 Main Street
Brooklyn, NY 11201

Revision Schedule

Revision Number	Revision Description	Revision Date
-----------------	----------------------	---------------

SCHEMATIC DESIGN

Scale: AS NOTED
Date: 6/22/2020
Project No: 2005
Drawn by:
Checked by:

Seal & Signature:

DOB Stamp & Signature

DOB Scan:

Drawing Title:

Overall Floor Plans

Drawing Number:

AA-107

DWG.No: of

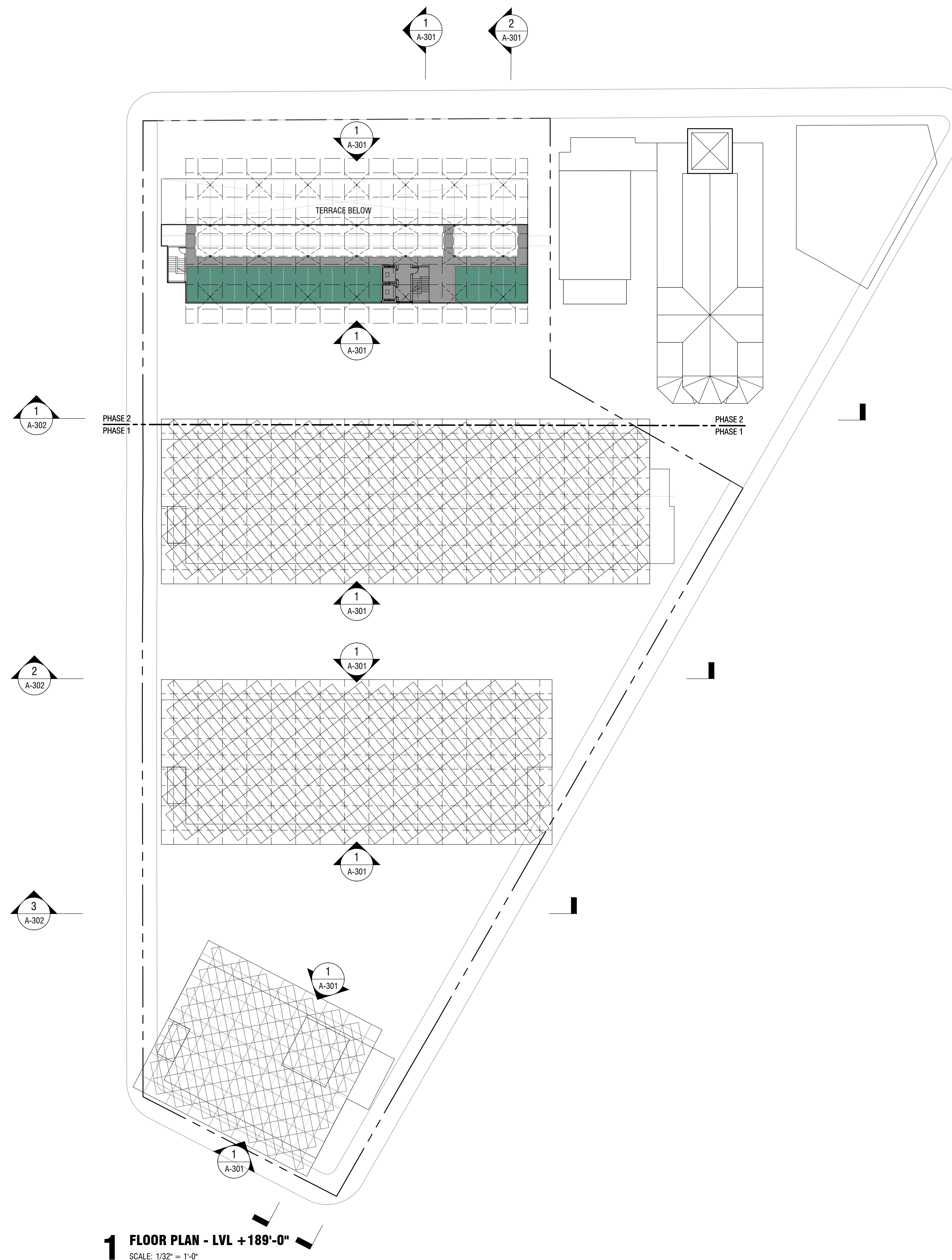

1 FLOOR PLAN - LVL +189'-0"
SCALE: 1/32" = 1'-0"

The Seventy-Six

Parcel 76, 76 Second Avenue, City of Albany, NY

Owner: South End Development LLC

Architect:
Garrison-Architects
45 Main Street
Brooklyn, NY 11201

Revision Schedule

Revision Number	Revision Description	Revision Date

SCHEMATIC DESIGN

Scale: AS NOTED
Date: 6/22/2020
Project No: 2005
Drawn by:
Checked by:

Seal & Signature:

DOB Stamp & Signature

DOB Scan:

Drawing Title:
Building Sections - Elevations - SITE

Drawing Number:
AA-201

DWG.No: of

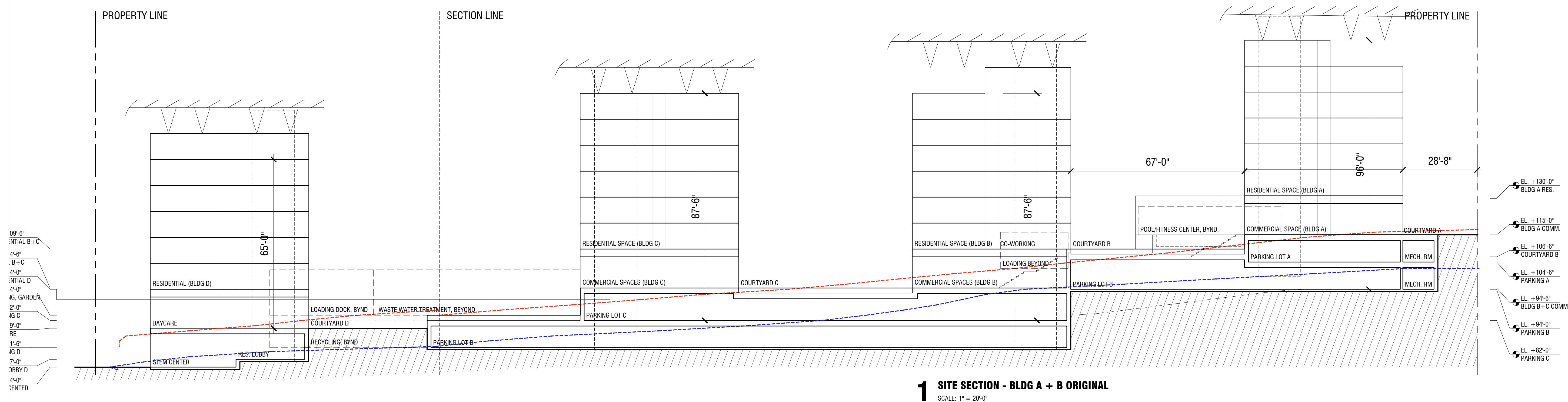

1 SITE SECTION - BLDG A + B ORIGINAL
SCALE: 1" = 20'-0"

The Seventy-Six

Parcel 76, 76 Second Avenue, City of Albany, NY

Owner: South End Development LLC

Architect: Garrison-Architects
45 Main Street
Brooklyn, NY 11201

Revision Schedule

Revision Number	Revision Description	Revision Date

SCHEMATIC DESIGN

Scale: AS NOTED
Date: 6/22/2020
Project No: 2005
Drawn by:
Checked by:

Seal & Signature:

DOB Stamp & Signature

DOB Scan:

Drawing Title:

Building Sections - Elevations - BLDG A - North South

Drawing Number:

AA-202

DWG.No: of

PROPERTY LINE



PROPERTY LINE

- EL. +190'-0" BLDG A RES ROOF
- EL. +179'-0" BLDG A RES LEVEL 6
- EL. +169'-0" BLDG A RES LEVEL 5
- EL. +159'-0" BLDG A RES LEVEL 4
- EL. +149'-0" BLDG A RES LEVEL 3
- EL. +139'-0" BLDG A RES LEVEL 2
- EL. +129'-0" BLDG A RES LEVEL 1
- EL. +114'-0" BLDG A COMM
- EL. +109'-0" COURTYARD B
- EL. +99'-0" PARKING A

2 BUILDING A SOUTH ELEVATION
SCALE: 1/12" = 1'-0"

PROPERTY LINE



PROPERTY LINE

- EL. +190'-0" BLDG A RES ROOF
- EL. +180'-0" BLDG A TERRACE
- EL. +169'-0" BLDG A RES LEVEL 5
- EL. +159'-0" BLDG A RES LEVEL 4
- EL. +149'-0" BLDG A RES LEVEL 3
- EL. +139'-0" BLDG A RES LEVEL 2
- EL. +129'-0" BLDG A RES LEVEL 1
- EL. +114'-0" BLDG A COMM
- EL. +109'-0" COURTYARD B
- EL. +99'-0" PARKING A

1 BUILDING A NORTH ELEVATION
SCALE: 1/12" = 1'-0"

The Seventy-Six

Parcel 76, 76 Second Avenue, City of Albany, NY

Owner: South End Development LLC

Architect:
Garrison-Architects
45 Main Street
Brooklyn, NY 11201

Revision Schedule

Revision Number	Revision Description	Revision Date

SCHEMATIC DESIGN

Scale: AS NOTED
Date: 6/22/2020
Project No: 2005
Drawn by:
Checked by:

Seal & Signature:

DOB Stamp & Signature

DOB Scan:

Drawing Title:
Building Sections - Elevations - BLDG A - East West

Drawing Number:
AA_203

DWG.No: of

PROPERTY LINE

PROPERTY LINE

- EL. +129'-0" BLDG A COMM.
- EL. +114'-0" BLDG A COMM.
- EL. +109'-0" COURTYARD B
- EL. +99'-0" PARKING A
- EL. +94'-0" BLDG B+C COMM.
- EL. +89'-0" PARKING B
- EL. +84'-0" PARKING C

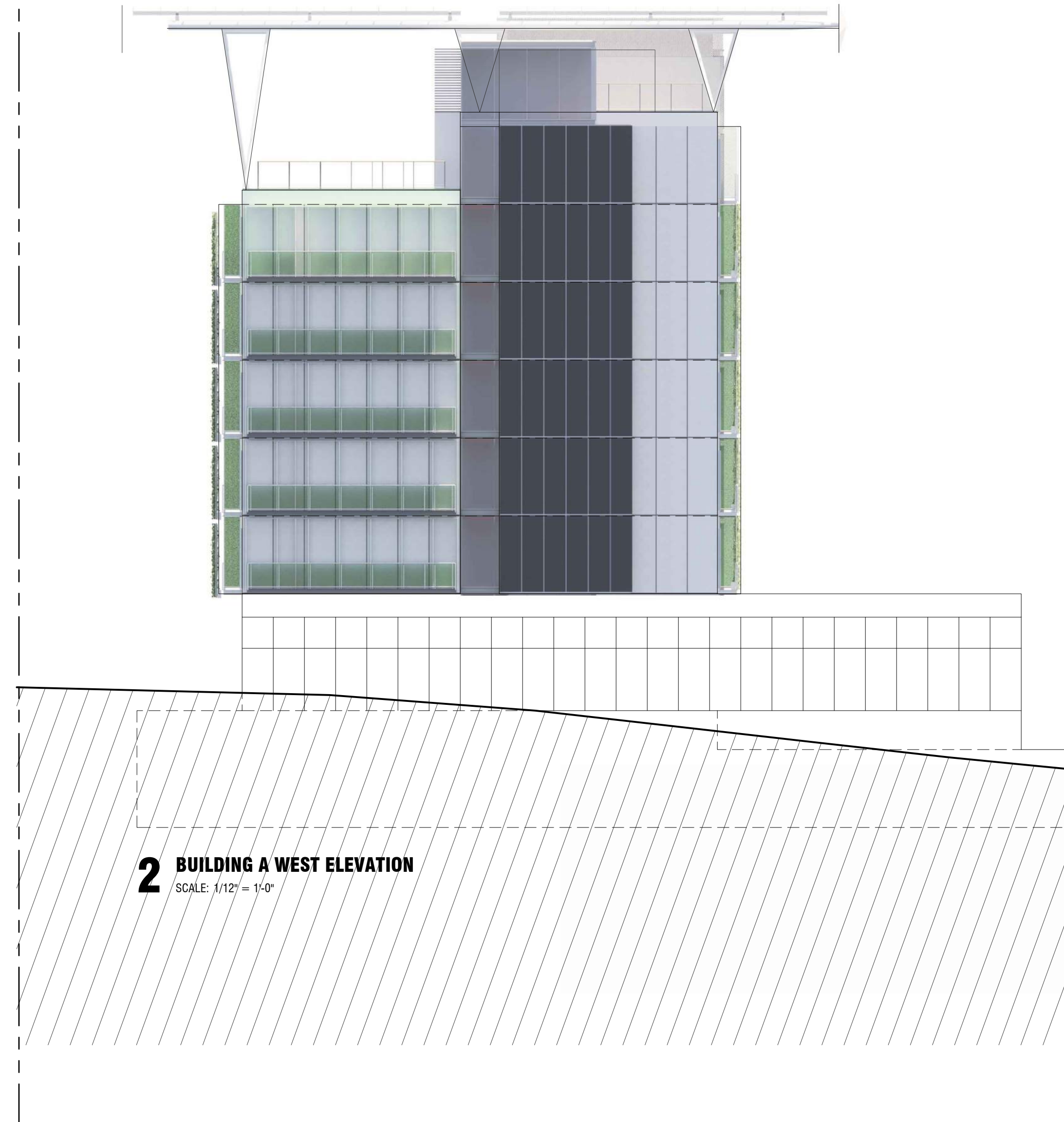

- EL. +129'-0" BLDG A COMM.
- EL. +114'-0" BLDG A COMM.
- EL. +109'-0" COURTYARD B
- EL. +99'-0" PARKING A
- EL. +94'-0" BLDG B+C COMM.
- EL. +89'-0" PARKING B
- EL. +84'-0" PARKING C

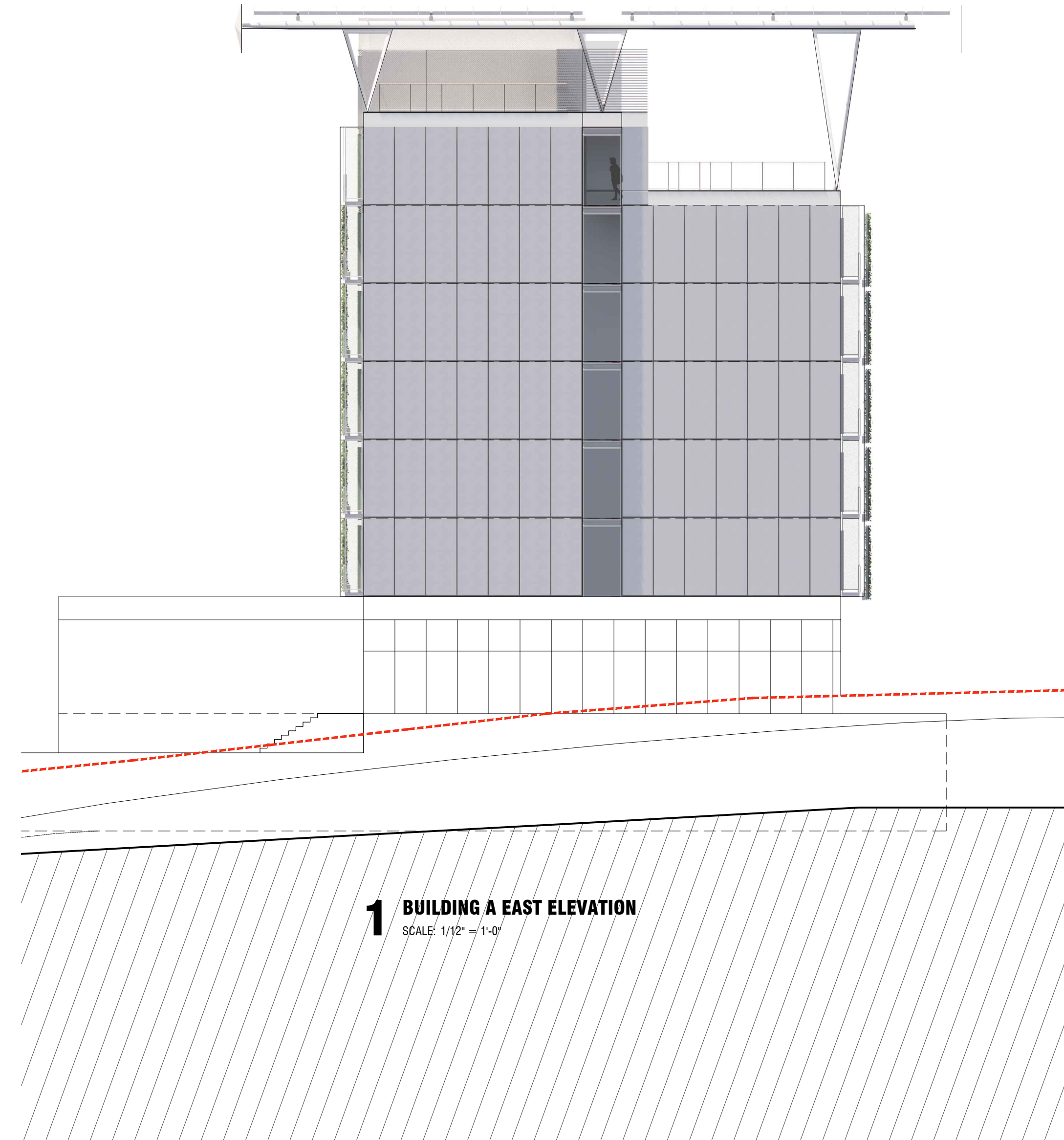

The Seventy-Six

Parcel 76, 76 Second Avenue, City of Albany, NY

Owner: South End Development LLC

Architect:
Garrison-Architects
45 Main Street
Brooklyn, NY 11201

Revision Schedule

Revision Number	Revision Description	Revision Date

SCHEMATIC DESIGN

Scale: AS NOTED
Date: 6/22/2020
Project No: 2005
Drawn by:
Checked by:

Seal & Signature:

DOB Stamp & Signature

DOB Scan:

Drawing Title:
Building Sections - Elevations - BLDG B - North South

Drawing Number:
AA-204

DWG.No: of

PROPERTY LINE

- EL. +180'-0" BLDG B ROOF
- EL. +169'-0" BLDG B RES LVL 7
- EL. +159'-0" BLDG B RES LVL 6
- EL. +149'-0" BLDG B RES LVL 5
- EL. +139'-0" BLDG B RES LVL 4
- EL. +129'-0" BLDG B RES LVL 3
- EL. +119'-0" BLDG B RES LVL 2
- EL. +109'-0" BLDG B RES LVL 1
- EL. +94'-0" BLDG B+C COMM
- EL. +84'-0" PARKING B
- EL. +74'-0" PARKING C

2 BUILDING B SOUTH ELEVATION
SCALE: 1/12" = 1'-0"

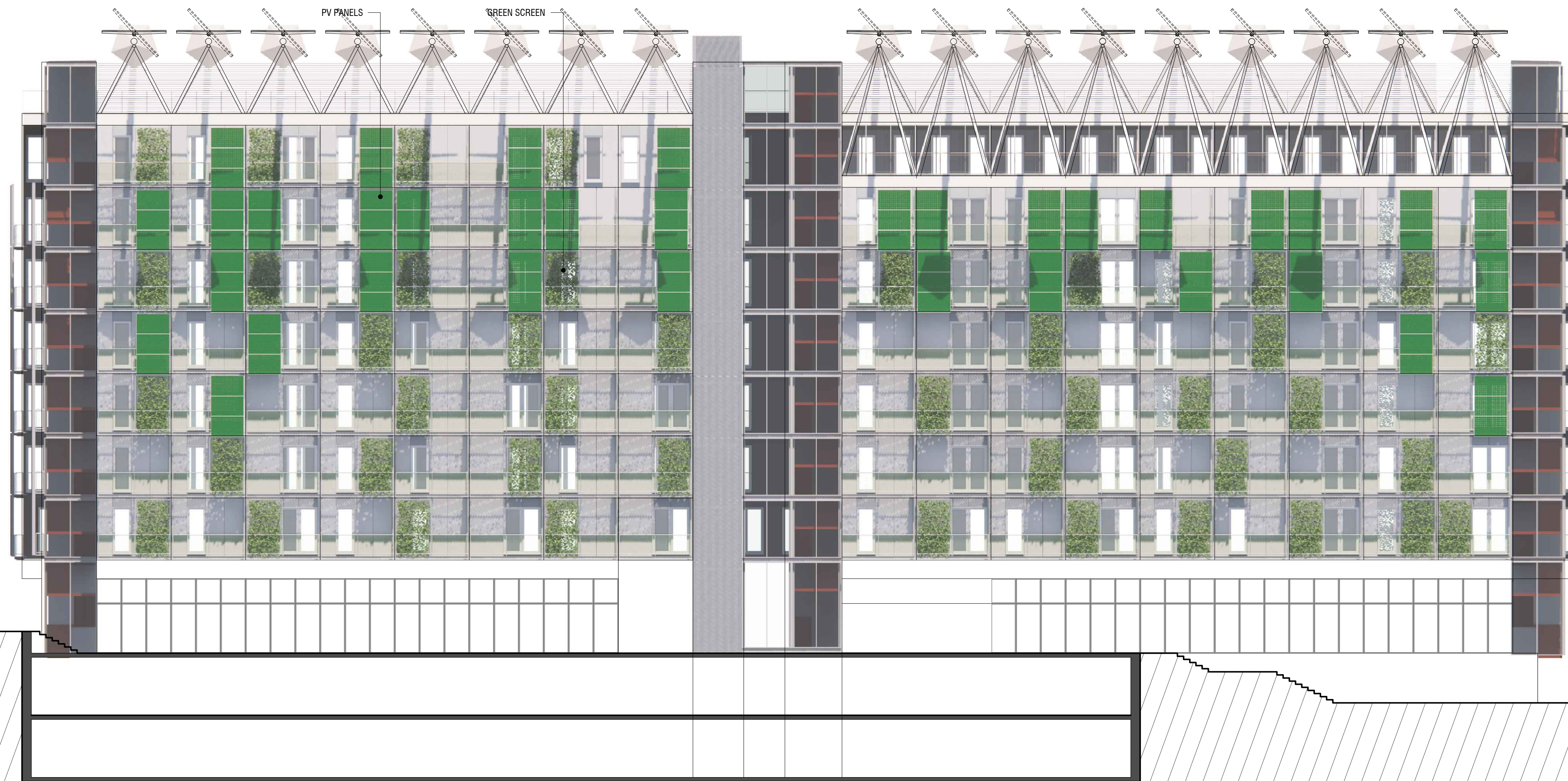

PROPERTY LINE

- EL. +109'-0" COURTYARD B
- EL. +94'-0" BLDG B+C COMM.
- EL. +84'-0" PARKING B

PROPERTY LINE

- EL. +180'-0" BLDG B ROOF
- EL. +169'-0" BLDG B RES LVL 7
- EL. +159'-0" BLDG B RES LVL 6
- EL. +149'-0" BLDG B RES LVL 5
- EL. +139'-0" BLDG B RES LVL 4
- EL. +129'-0" BLDG B RES LVL 3
- EL. +119'-0" BLDG B RES LVL 2
- EL. +109'-0" BLDG B RES LVL 1

1 BUILDING B NORTH ELEVATION
SCALE: 1/12" = 1'-0"



PROPERTY LINE

- EL. +109'-0" BLDG B+C RES
- EL. +99'-0" PARKING A

The Seventy-Six

Parcel 76, 76 Second Avenue, City of Albany, NY

Owner: South End Development LLC

Architect:
Garrison-Architects
45 Main Street
Brooklyn, NY 11201

Revision Schedule

Revision Number	Revision Description	Revision Date

SCHEMATIC DESIGN

Scale: AS NOTED
Date: 6/22/2020
Project No: 2005
Drawn by:
Checked by:

Seal & Signature:

DOB Stamp & Signature

DOB Scan:

Drawing Title:
Building Sections - Elevations - BLDG B - East West

Drawing Number:
AA-205

DWG.No: of

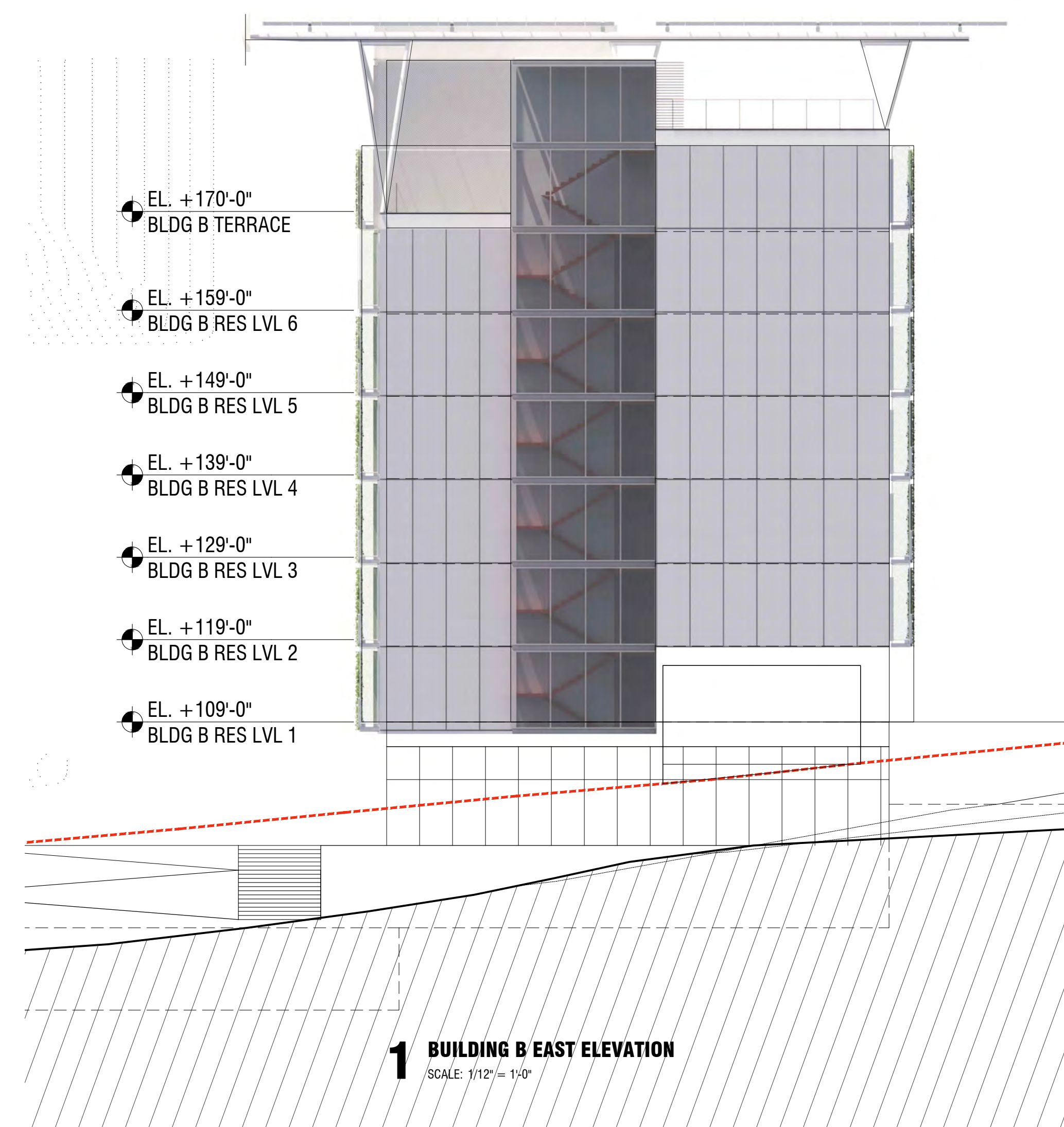
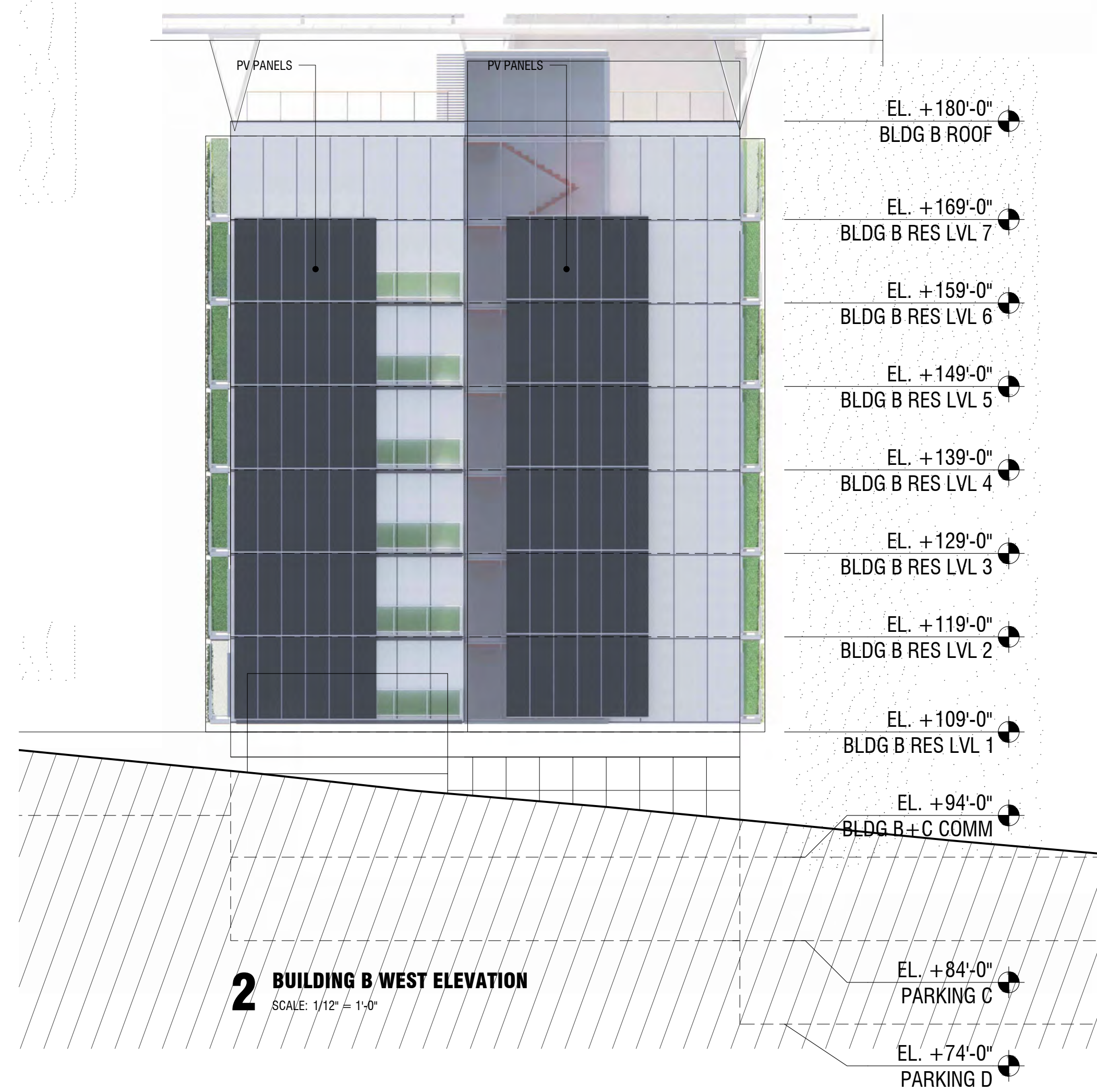

The Seventy-Six

Parcel 76, 76 Second Avenue, City of Albany, NY

Owner: South End Development LLC

Architect:
Garrison-Architects
45 Main Street
Brooklyn, NY 11201

Revision Schedule

Revision Number	Revision Description	Revision Date

SCHEMATIC DESIGN

Scale: AS NOTED
Date: 6/22/2020
Project No: 2005
Drawn by:
Checked by:

Seal & Signature:

DOB Stamp & Signature

DOB Scan:

Drawing Title:
Building Sections - Elevations - BLDG C - North South

Drawing Number:
AA-206

DWG.No: of

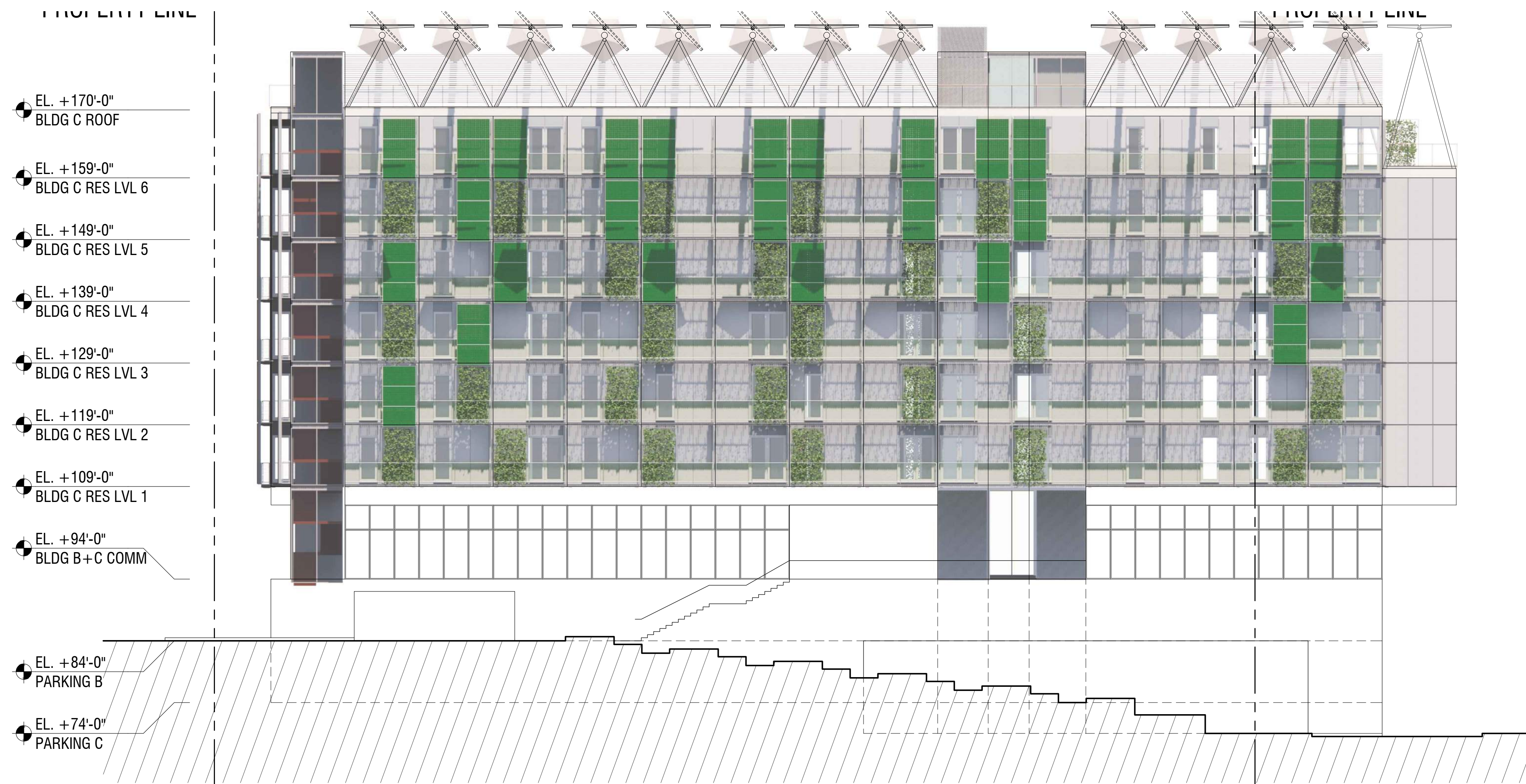

2 BUILDING C SOUTH ELEVATION
SCALE: 1/12" = 1'-0"

PROPERTY LINE

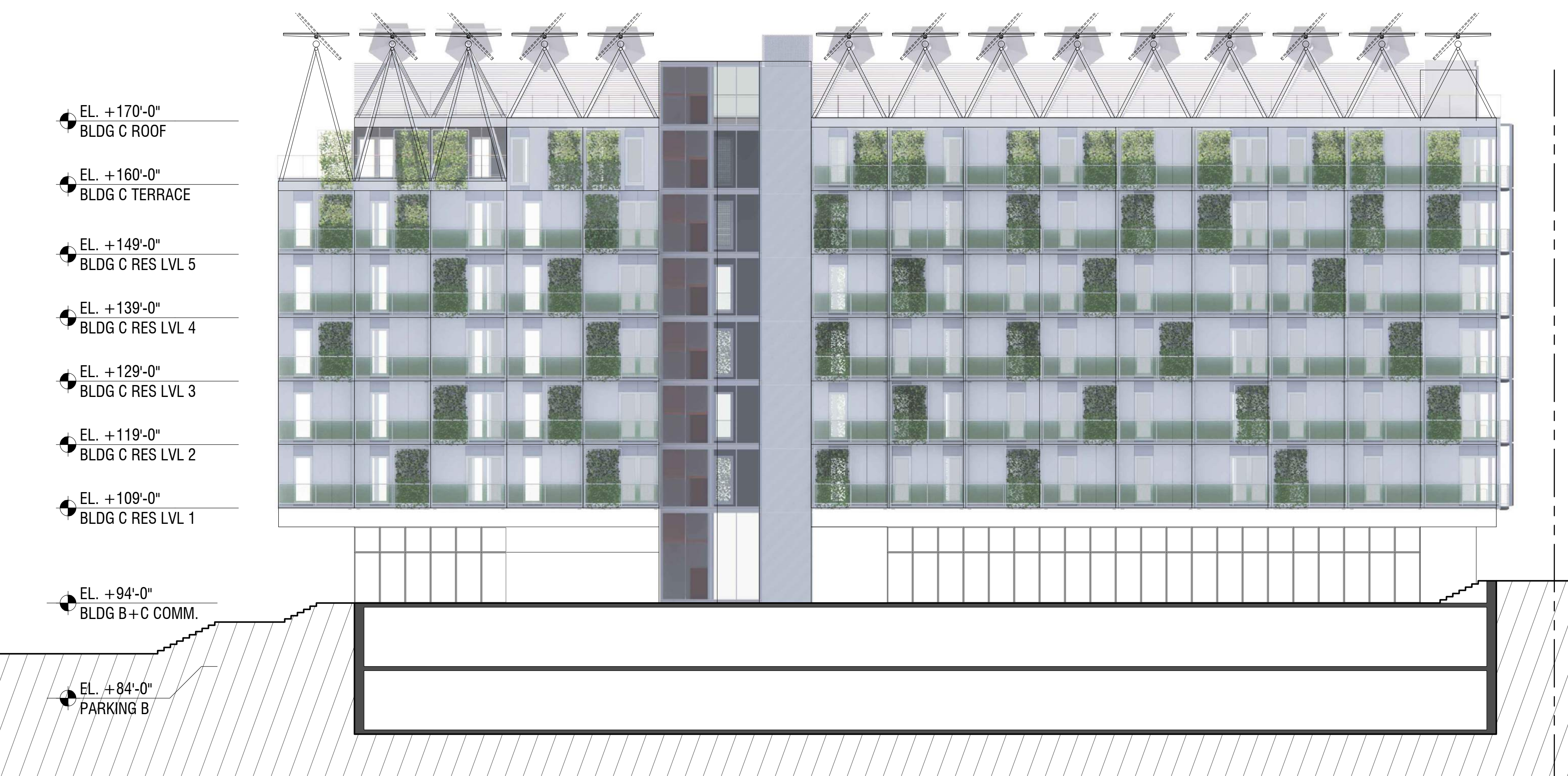

1 BUILDING C NORTH ELEVATION
SCALE: 1/12" = 1'-0"

PROPERTY LINE

- EL. +170'-0" BLDG C ROOF
- EL. +160'-0" BLDG C TERRACE
- EL. +149'-0" BLDG C RES LVL 5
- EL. +139'-0" BLDG C RES LVL 4
- EL. +129'-0" BLDG C RES LVL 3
- EL. +119'-0" BLDG C RES LVL 2
- EL. +109'-0" BLDG C RES LVL 1
- EL. +94'-0" BLDG B+C COMM.
- EL. +84'-0" PARKING B
- EL. +109'-0" BLDG B+C RES
- EL. +94'-0" BLDG B+C COMM.
- EL. +84'-0" PARKING B
- EL. +74'-0" PARKING C

The Seventy-Six

Parcel 76, 76 Second Avenue, City of Albany, NY

Owner: South End Development LLC

Architect:
Garrison-Architects
45 Main Street
Brooklyn, NY 11201

Revision Schedule

Revision Number	Revision Description	Revision Date

SCHEMATIC DESIGN

Scale: AS NOTED
Date: 6/22/2020
Project No: 2005
Drawn by:
Checked by:

Seal & Signature:

DOB Stamp & Signature

DOB Scan:

Drawing Title:
Building Sections - Elevations - BLDG C - East West

Drawing Number:
AA-207

DWG.No: of

SECTION LINE

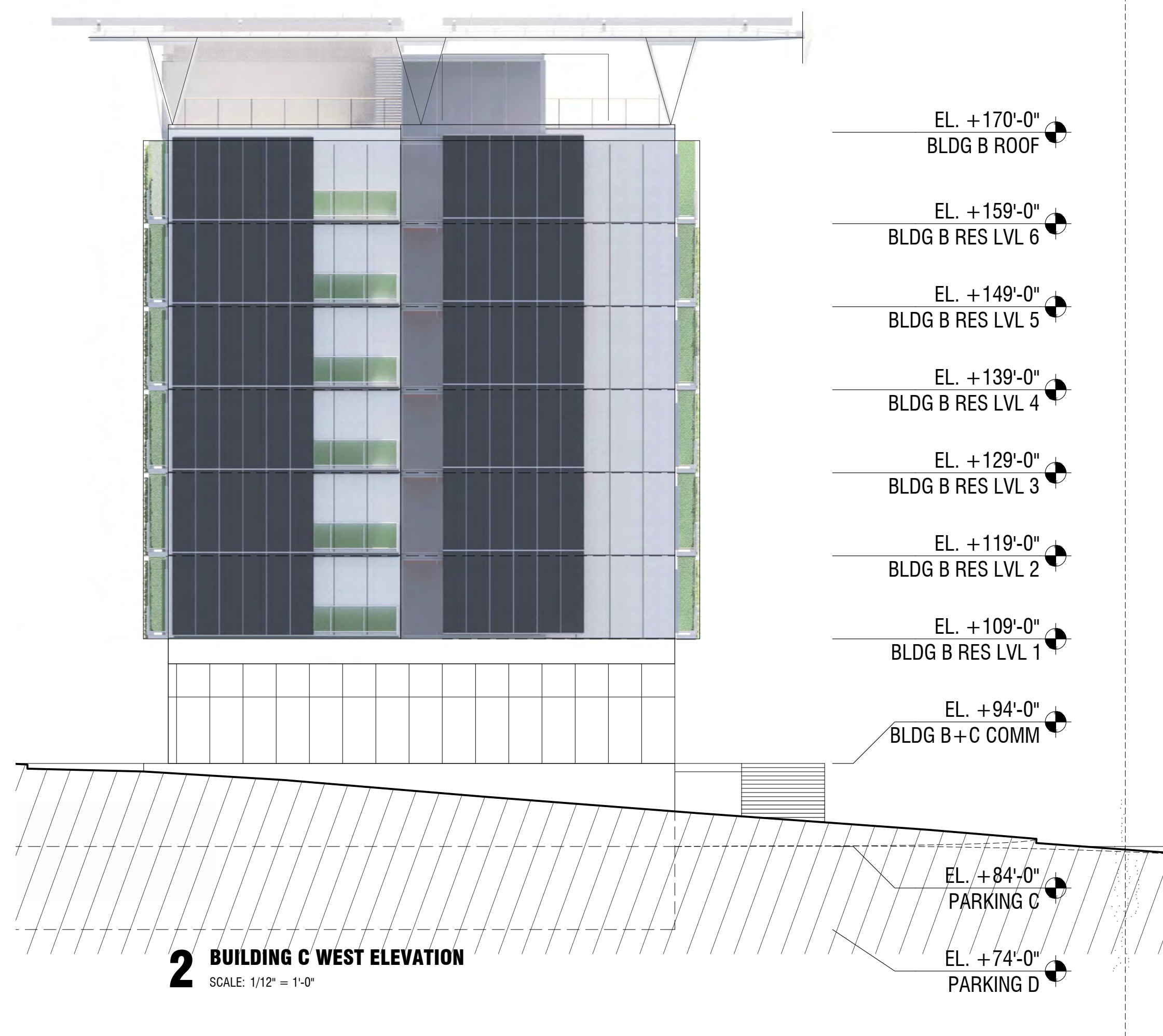

SECTION LINE

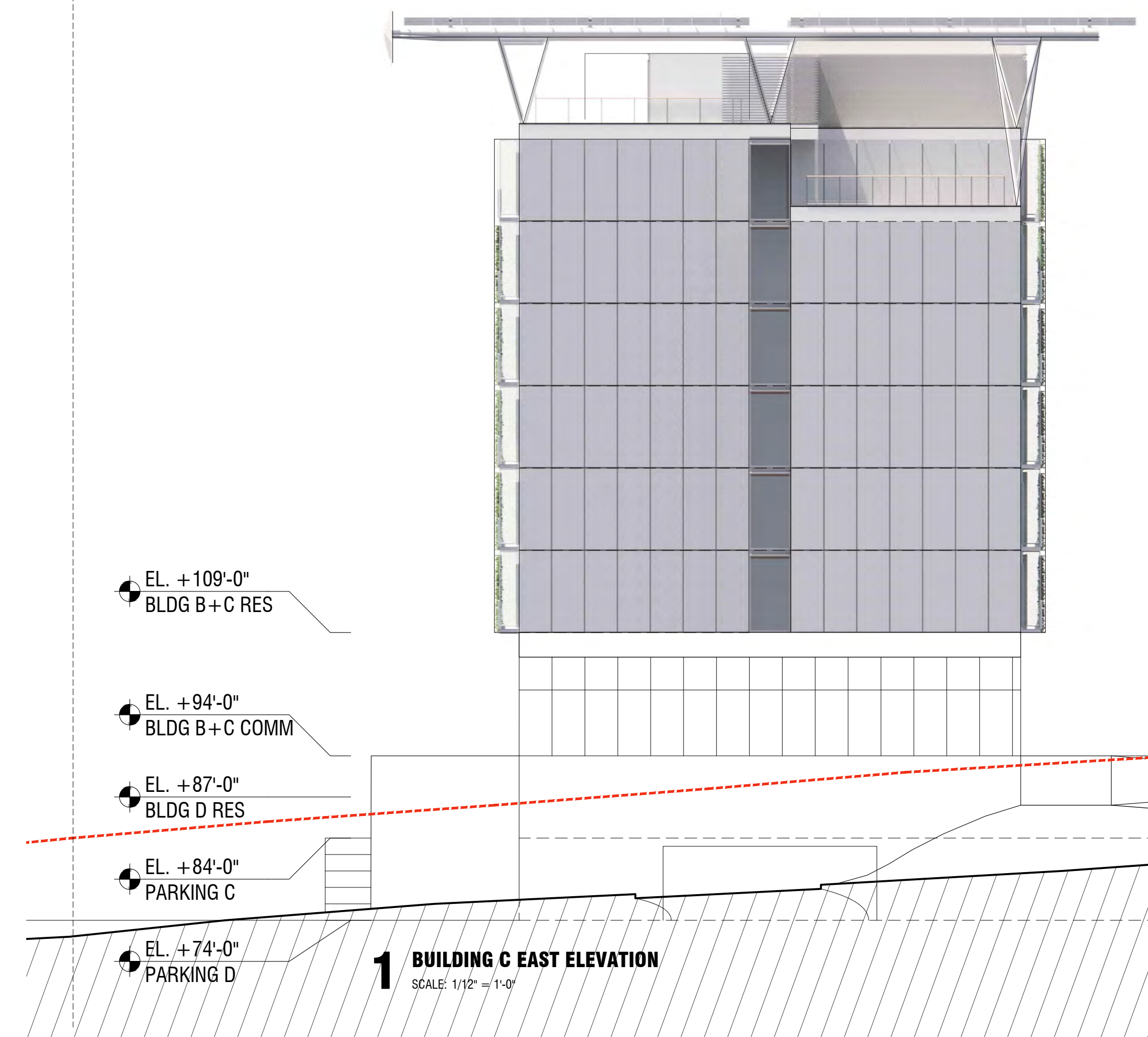

The Seventy-Six

Parcel 76, 76 Second Avenue, City of Albany, NY

Owner: South End Development LLC

Architect:
Garrison-Architects
45 Main Street
Brooklyn, NY 11201

Revision Schedule

Revision Number	Revision Description	Revision Date

SCHEMATIC DESIGN

Scale: AS NOTED
Date: 6/22/2020
Project No: 2005
Drawn by:
Checked by:

Seal & Signature:

DOB Stamp & Signature

DOB Scan:

Drawing Title:

Building Sections - Elevations - BLDG D - North South

Drawing Number:

AA-208

DWG.No: of

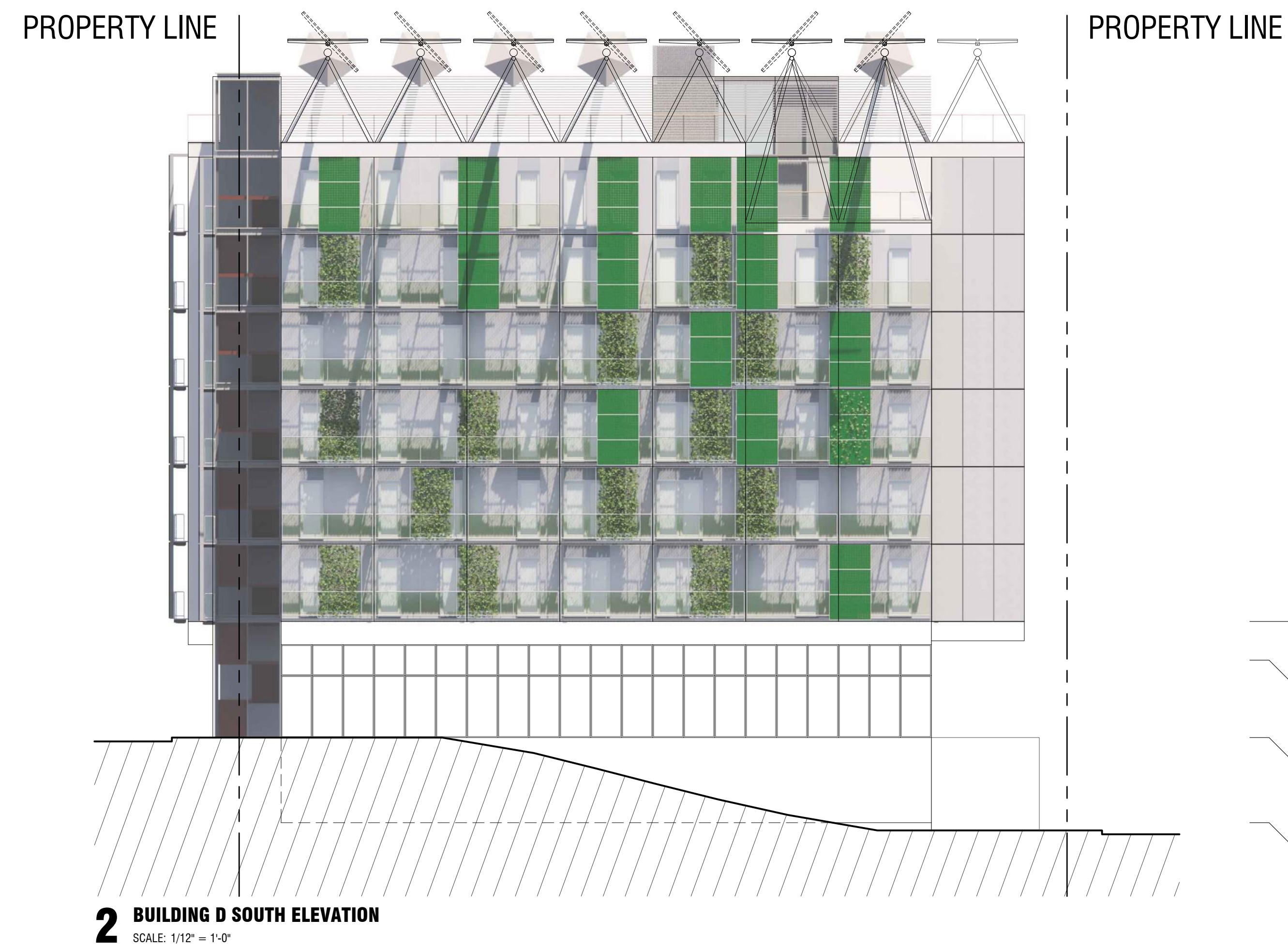

The Seventy-Six

Parcel 76, 76 Second Avenue, City of Albany, NY

Owner: South End Development LLC

Architect:
Garrison-Architects
45 Main Street
Brooklyn, NY 11201

Revision Schedule

Revision Number	Revision Description	Revision Date

SCHEMATIC DESIGN

Scale: AS NOTED
Date: 6/22/2020
Project No: 2005
Drawn by:
Checked by:

Seal & Signature:

DOB Stamp & Signature

DOB Scan:

Drawing Title:
Building Sections - Elevations - BLDG D - East West

Drawing Number:
AA-209

DWG.No: of

PROPERTY LINE

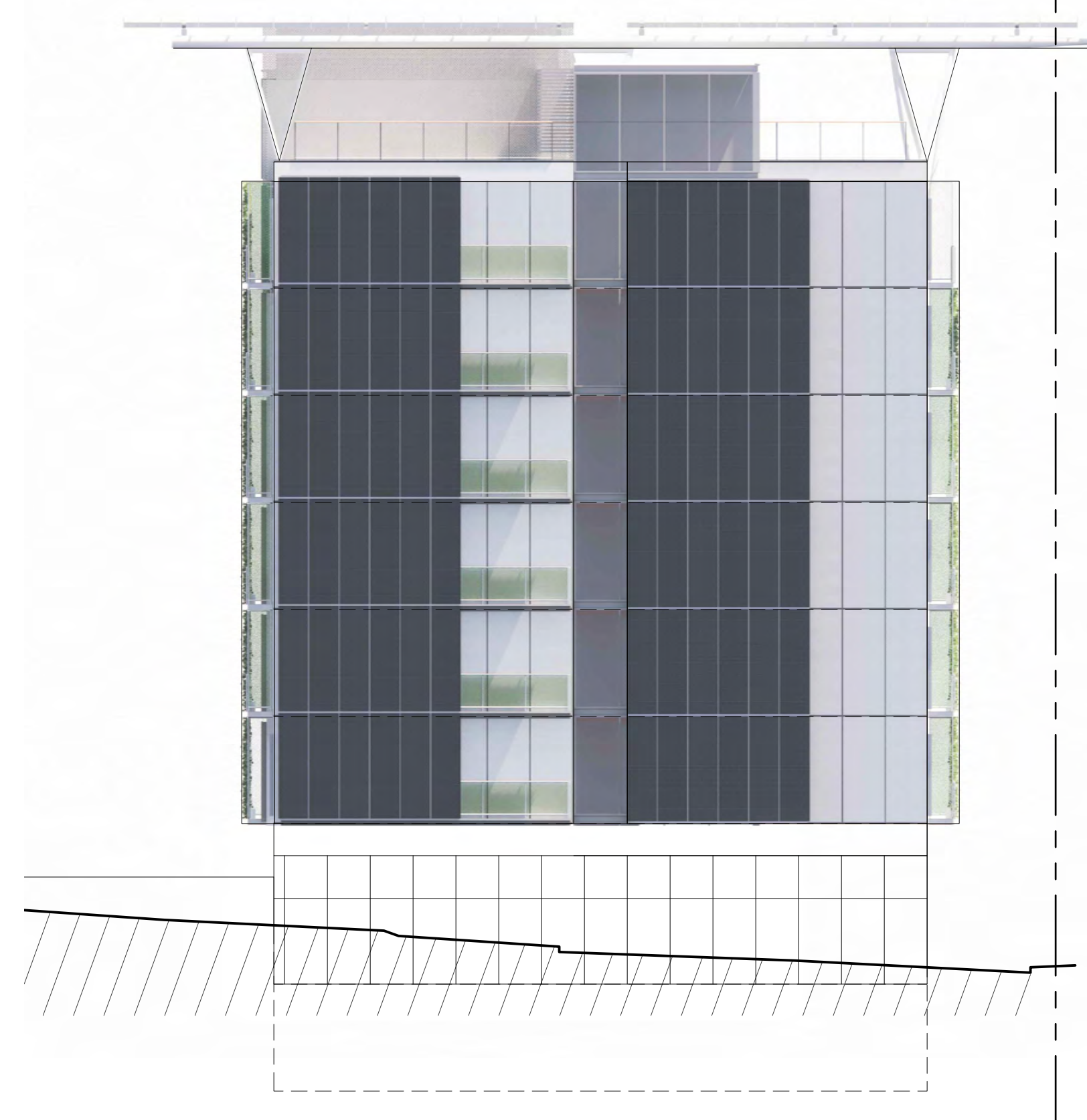

2 BUILDING C WEST ELEVATION
SCALE: 1/12" = 1'-0"

EL. +109'-0"
BLDG B+C RES

EL. +94'-0"
BLDG B+C COMM

EL. +87'-0"
BLDG D RES

EL. +84'-0"
PARKING C

EL. +74'-0"
PARKING D

EL. +63'-0"
BLDG D COMM

EL. +109'-0"
BLDG B+C RES

EL. +94'-0"
BLDG B+C COMM

EL. +87'-0"
BLDG D RES

EL. +84'-0"
PARKING C

EL. +74'-0"
PARKING D

EL. +63'-0"
BLDG D COMM

PROPERTY LINE

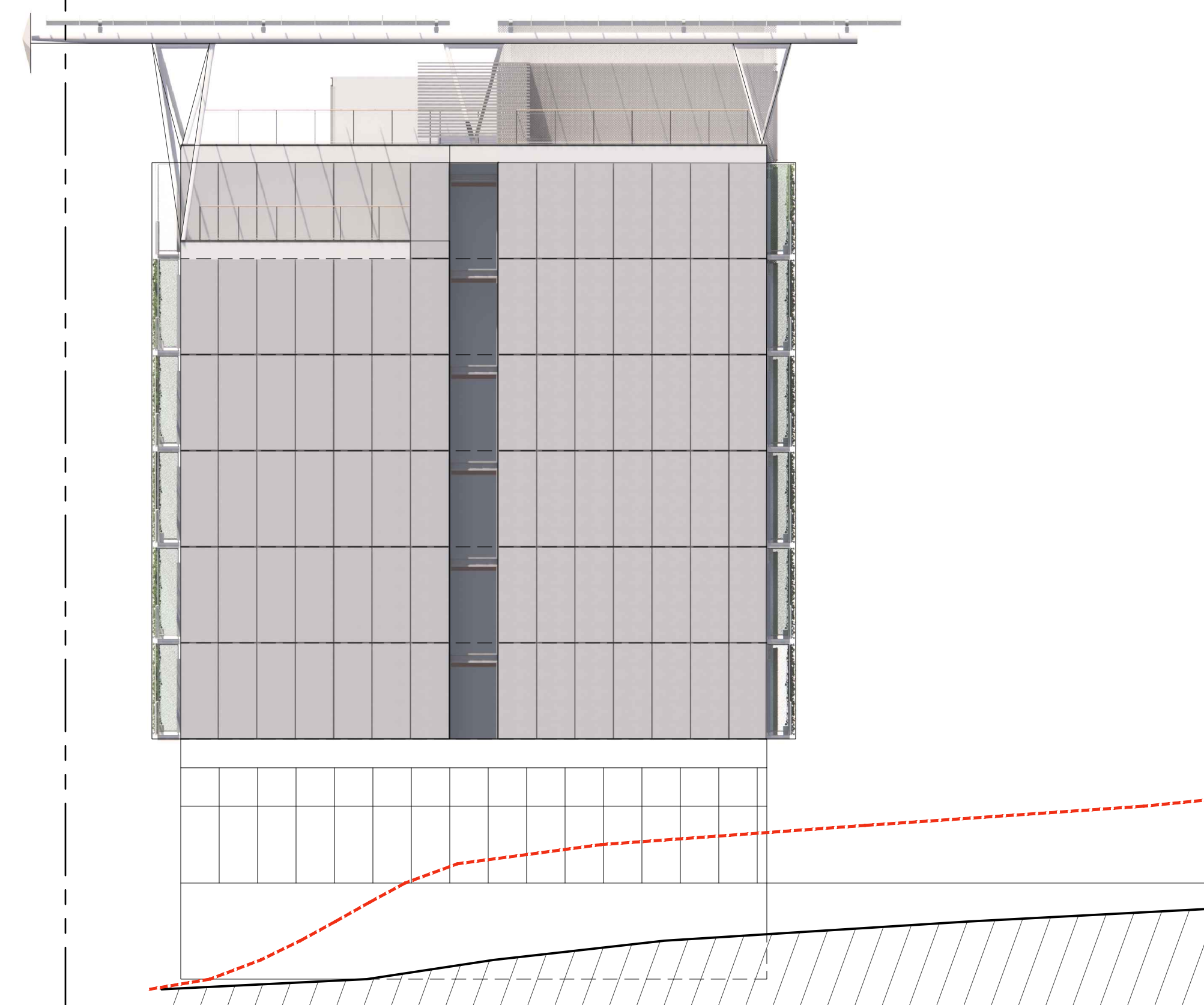

1 BUILDING D EAST ELEVATION
SCALE: 1/12" = 1'-0"