

Ø90' FABRICATED ALUM. LETTER, PAINT FACE MATTHEWS #MP-41306 BLACK SEMI-GLOSS & RETURNS MATTHEWS #MP-18101 CHASE LIGHT NICKEL SEMI-GLOSS

Ø90' FABRICATED ALUM. OCTAGON SEGMENT PAINTED MATTHEWS #MP-49353 METALLIC BLUE SATIN FINISH (4 SEGMENTS REQ'D)

ELEVATION & MOUNTING LOCATIONS

CHISELED OCTAGON TO BE MANUFACTURED & INSTALLED AS (4) INDIVIDUAL SEGMENTS

ALL EXPOSED FASTENER HEADS SHALL BE PAINTED TO MATCH THE EXTERIOR CABINET FINISH

General Notes:

- Design is based on a 115 mph, 3 second gust wind design per IBC 2012 (ASCE 7-10). Category II, Exposure C. Components and Cladding Zone 5.
- No additional wind catching surfaces are added to the building structure. The customer's building engineer is to determine the adequacy of the supporting structure.
- Extruded aluminum shapes shall be 6061-T6 alloy. Aluminum sheet shall be 3003-H14 alloy. Aluminum plate shall be 5052-H34 alloy.
- All welds shall be made using a 4000 series filler for aluminum by persons qualified in accordance with AWS standards within the past two years.
- All fasteners shall be stainless steel or zinc coated to prevent corrosion.
- All wall penetrations shall be sealed to prevent water penetration.
- J.P. Morgan Chase will not be responsible for the safety on the job site before, during or after installation of this structure. It is the responsibility of the contractors and installers to ensure that the installation and erection of this structure is performed using methods that are in full compliance with OSHA regulations.
- Any deviation from this design or from any part of this drawing, including the General Notes, without prior written consent from J.P. Morgan Chase voids this drawing in its entirety.
- The structure designed on this drawing is prototypical and should not be used for site specific applications unless deemed suitable by a Competent Professional Engineer.

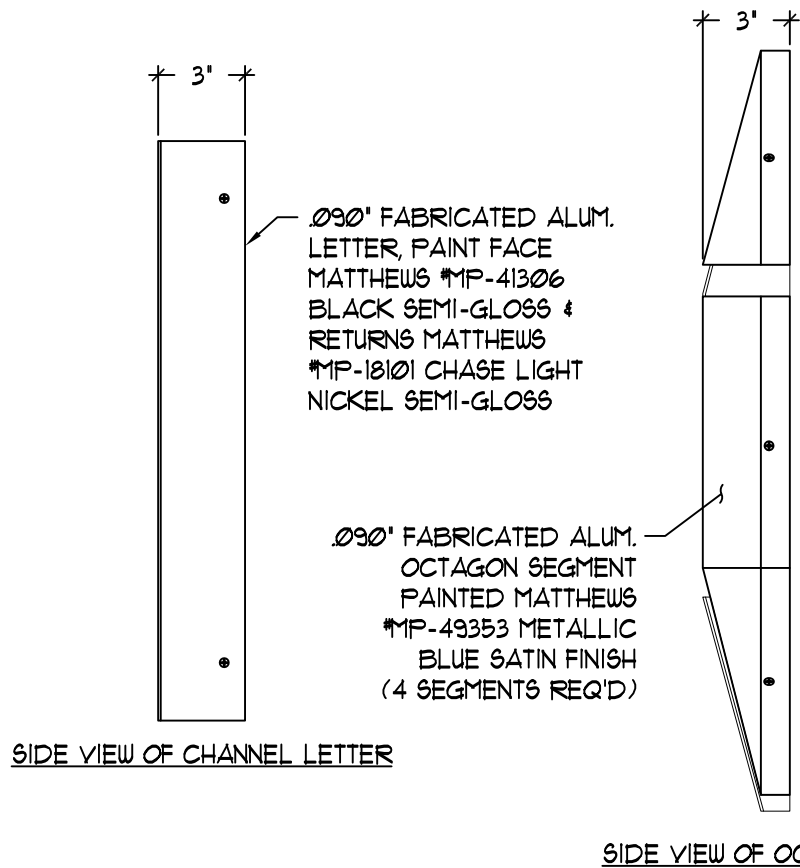

SIDE VIEW OF CHANNEL LETTER

SIDE VIEW OF OCTAGON

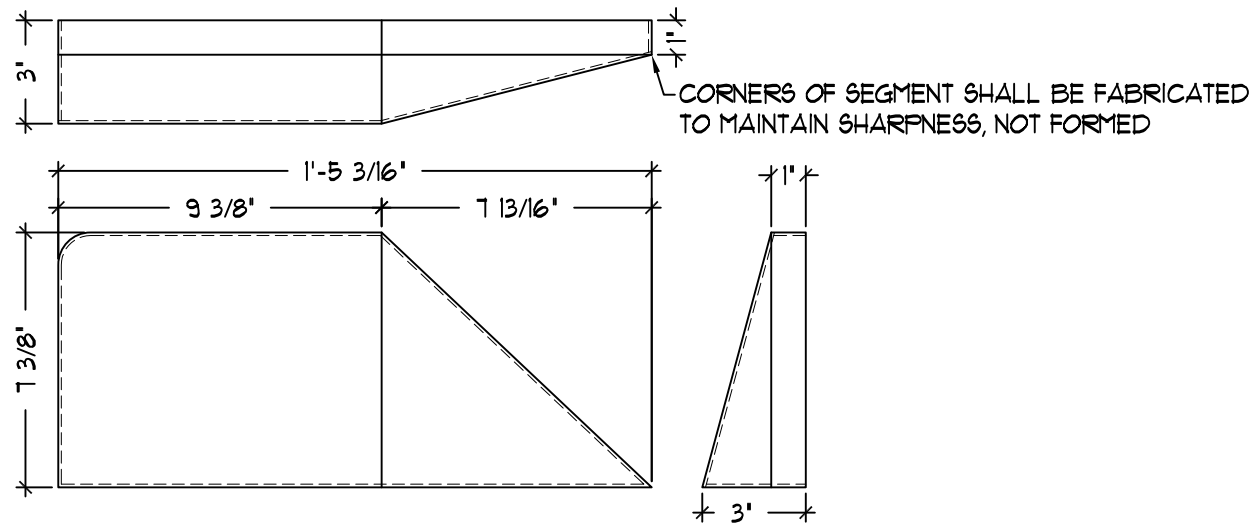

OCTAGON SEGMENT DETAIL

CORNERS OF SEGMENT SHALL BE FABRICATED TO MAINTAIN SHARPNESS, NOT FORMED

SEE SHEET 1 OF 1 FOR PREFERRED DISCONNECT SWITCH LOCATION FOR REMOTE, NON-PARAPET WALL INSTALLATION

MANUFACTURER TO PROVIDE A TEMPLATE TO ENSURE PROPER ALIGNMENT OF SIGN ELEMENTS AT INSTALLATION



These documents represent prototypical design drawings created specifically for use by J.P. Morgan Chase. Use of this unpublished work for any purpose other than the intended application is strongly discouraged. Disclosure or reproduction of any of the information contained within these documents without the written consent of the owner is strictly prohibited.

SHT.	BY:	Project No.	Δ	---	---	---
1	GHK	08-1218	Δ	---	---	---
OF	DATE:	Drawing No.	Δ	9/23/16	CHANGED PERMLIGHT LED's TO GE	TRR IK
7	5/24/12	B244444	Δ	1/8/14	REVISED TO CHISELED (REPARATED) OCTAGON & CHANGED SEAL-TITE CONDUIT TO EMT CONDUIT ON PARAPET WALL SECTIONS	TRR IK
			REV.	DATE	DESCRIPTION	BY: AFR

GRAPHICS DEPICTED ARE FOR ILLUSTRATIVE PURPOSES ONLY! USE ONLY APPROVED ARTWORK FOR PRODUCTION.

DESIGNATION:
LIH-BLK-20