

NOTE:

**This SWMR was prepared in accordance with
the Unified Sustainable Development Ordinance.**

STORM WATER MANAGEMENT REPORT (SWMR)

90 State Street Apartment Conversion

90 State Street

CITY OF ALBANY
COUNTY OF ALBANY
STATE OF NEW YORK

Applicant: Harmony Mill South, LLC

PREPARED BY:

HERSHBERG & HERSHBERG



CONSULTING ENGINEERS

18 Locust Street
Albany, NY 12203-2908
Phone 518-459-3096
Fax 518-459-5683
Email hhershberg@aol.com

October 31, 2017

Table of Contents

Introduction	1
Description of Existing Site	1
Description of Intended Site Development and Use	2
Sewer System	2
Design Considerations.....	3
Summary.....	4
Conclusion & Certification	4

Appendices

- Appendix #1 – HydroCAD® 10.00 Calculations
- Appendix #2 – Maintenance Plan
- Appendix #3 – Maintenance Agreement
- Appendix #4 – Detail of Roof Drains

Map Pockets

- Map Pocket #1 – Existing Conditions and Sewer Connection Permit Plan – Sheet C-1

INTRODUCTION:

Hershberg & Hershberg, Consulting Engineers and Land Surveyors, were retained by Harmony Mill South, LLC (hereinafter the “Applicant”) to review storm drainage for the proposed 90 State Street Apartment Conversion. This report is for the consideration of the Department of Water & Water Supply and the City of Albany Planning Board.

DESCRIPTION OF EXISTING SITE:

The existing parcel is Tax Map Parcel #76.42-1-5 listed as No. 90 State Street with a site area of 16,976 SF or 0.39 Acres. It is entirely occupied by a 15 story building.

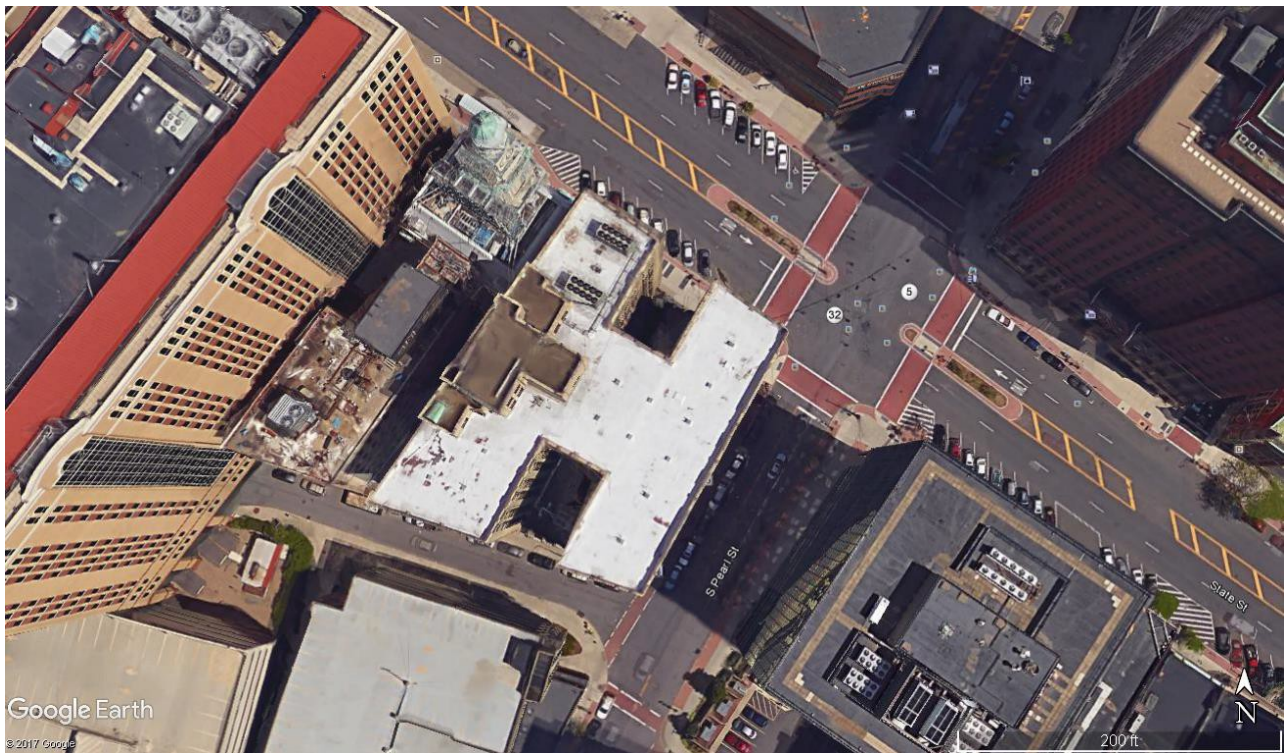

Fig. No. 1 - Aerial Photo of Site

DESCRIPTION OF INTENDED SITE DEVELOPMENT AND USE

Under the current application the Applicant is proposing to convert floors 4 through 12, 14 & 15 from office space to 154 apartments which would have 176 bedrooms. The existing uses on the Ground floor through the 3rd floor will remain. They include a banquet hall, fast food, retail, personal services and offices.

SEWER SYSTEM

The storm drainage from this site is tributary to a Central Area Sewer District as shown on the portion Sewer Atlas Sheet 31 reproduced below.

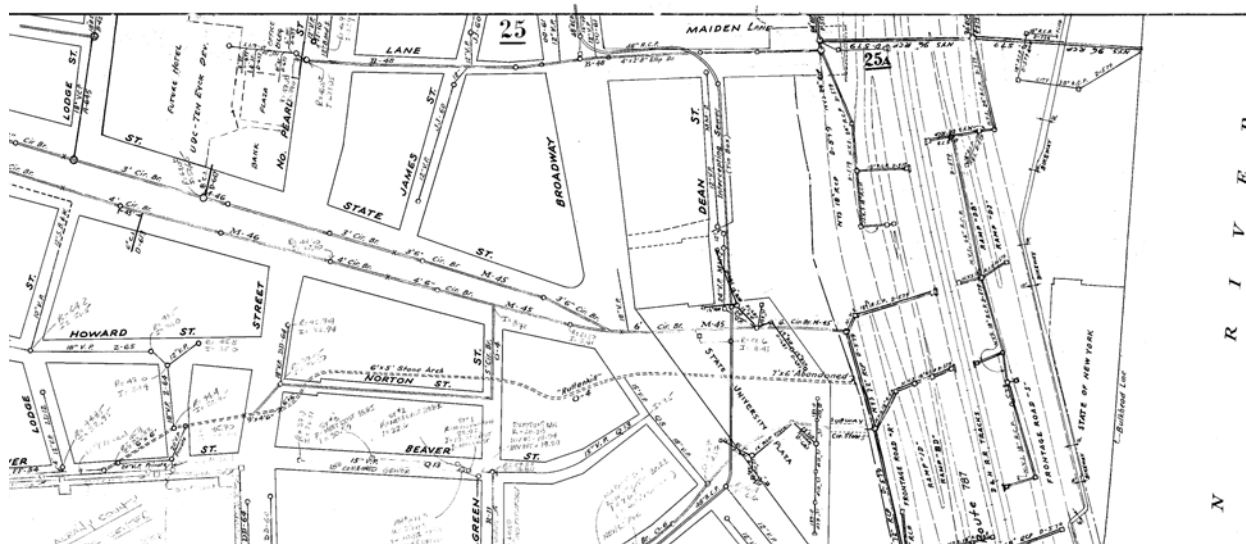

Fig. No. 2 – Portion of Sewer Atlas Sheet 31

The 4'6" diameter sewer is tributary to a 6' diameter sewer before entering a regulating chamber which control flows to the Intercepting Sewer. When the set amount of flow is exceeded the combined sewer discharges into a system constructed by New York State in connection with the construction of Interstate 787. When the system overflows it creates a Combined Sewer Overflow to the Hudson River. This site is within the Combined Sewer Overlay (CS-O) District. Blue Roofs are a permitted method in the Unified Sustainable Development Ordinance.

The sewer system is well equipped to accommodate storm water flows from small storms. The Applicant proposes to use slow release roof drains to control the outfall generated by roof drainage for all storms. See detail in Appendix 4. This is the “blue roof” solution considered as an acceptable method according to the Uniform Sustainable Development Ordinance and is recognized in §375-2(f)(4)(d)(i)(B).

In the order to determine the net impact of adding sanitary flow while reducing storm sewer from the one-year storm has been analyzed. Compared to the site in its totally unpaved condition the discharge from the developed site is reduced from 0.26 CFS to 0.19 CFS which is reduction of 0.07 CFS. For the 10-year storm the change in storm flow from the site in its totally unpaved condition to the discharge from the developed site is reduced from 1.04 CFS to 0.47 CFS which is reduction of 0.57 CFS. It should be noted that the actual reduction in flow from the existing condition is from 1.25 CFS to 0.19 CFS for the one-year storm and from 2.42 CFS to 0.47 CFS for the 10-year storm. These results are shown below in Fig. No.3.

Condition Analyzed	1 Year Storm Discharge (CFS)	10 Year Storm Discharge (CFS)
Pre Development (Totally Green)	0.26	1.04
Pre Development (Existing Cond.)	1.25	2.42
Post Development	0.19	0.47

Fig. No. 3 – Pre & Post HydroCAD Results

DESIGN CONSIDERATIONS:

The design of the SWMR for the subject site considered the following critical factors:

1. Compliance with Section 375-4(G)(11) of the Unified Sustainable Development Ordinance entitled STORMWATER MANAGEMENT which includes:
 - (d) The maximum allowable design peak-flow stormwater discharge into the combined sewer system shall be limited to the calculated peak-flow discharge of the **10-year storm for un-development site conditions**, as determined by

a Professional Engineer, and to be reviewed and accepted by the Department of Water and Water Supply. (emphasis added)

SUMMARY:

The following is a summary of the findings of this study as presented by the preparer of this report:

1. The permanent system complies with Section 375-4(G)(11) of the Unified Sustainable Development Ordinance entitled STORMWATER MANAGEMENT.

CONCLUSION & CERTIFICATION:

It is the conclusion of the Engineer that the erosion and sediment control system, as designed, and the permanent storage and treatment system will function adequately to clean the stormwater prior to discharge. Also, the Engineer certifies that the project will not adversely impact adjacent or downstream properties or the downstream sewer collection system.



Prepared by: _____
Daniel R. Hershberg, P.E. & L.S.
Lic. No. 44226

File:DRH/SWMR/SWMR20170316.DOC

APPENDIX #1

HYDROCAD® 10.00 CALCULATIONS

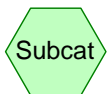
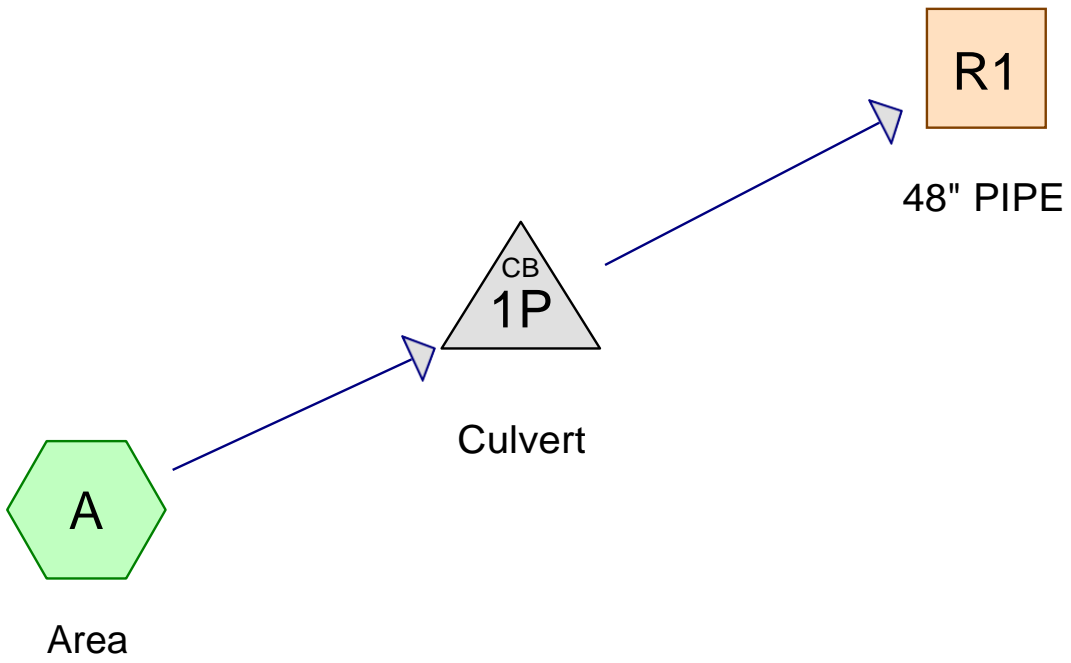

Subcat



Reach

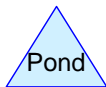

Pond



Link

Area Listing (all nodes)

Area (acres)	CN	Description (subcatchment-numbers)
0.326	74	>75% Grass cover, Good, HSG C (A)
0.326	74	TOTAL AREA

Soil Listing (all nodes)

Area (acres)	Soil Group	Subcatchment Numbers
0.000	HSG A	
0.000	HSG B	
0.326	HSG C	A
0.000	HSG D	
0.000	Other	
0.326		TOTAL AREA

170316-PRE

Ground Covers (all nodes)

HSG-A (acres)	HSG-B (acres)	HSG-C (acres)	HSG-D (acres)	Other (acres)	Total (acres)	Ground Cover	Subcatchment Numbers
0.000	0.000	0.326	0.000	0.000	0.326	>75% Grass cover, Good	A
0.000	0.000	0.326	0.000	0.000	0.326	TOTAL AREA	

170316-PRE

Prepared by Hershberg & Hershberg

HydroCAD® 10.00 s/n 03289 © 2012 HydroCAD Software Solutions LLC

Printed 10/20/2017

Page 5

Pipe Listing (all nodes)

Line#	Node Number	In-Invert (feet)	Out-Invert (feet)	Length (feet)	Slope (ft/ft)	n	Diam/Width (inches)	Height (inches)	Inside-Fill (inches)
1	R1	149.00	139.90	20.0	0.4550	0.015	48.0	0.0	0.0
2	1P	150.00	149.50	30.0	0.0167	0.013	6.0	0.0	0.0

170316-PRE

Type II 24-hr 1 YEAR Rainfall=2.50"

Prepared by Hershberg & Hershberg

Printed 10/20/2017

HydroCAD® 10.00 s/n 03289 © 2012 HydroCAD Software Solutions LLC

Page 6

Time span=0.00-40.00 hrs, dt=0.05 hrs, 801 points

Runoff by SCS TR-20 method, UH=SCS

Reach routing by Stor-Ind+Trans method - Pond routing by Stor-Ind method

Subcatchment A: Area

Runoff Area=14,210 sf 0.00% Impervious Runoff Depth=0.61"

Flow Length=76' Slope=0.0100 '/' Tc=11.5 min CN=74 Runoff=0.26 cfs 0.017 af

Reach R1: 48" PIPE

Avg. Flow Depth=0.05' Max Vel=7.89 fps Inflow=0.26 cfs 0.017 af

48.0" Round Pipe n=0.015 L=20.0' S=0.4550 '/' Capacity=839.74 cfs Outflow=0.26 cfs 0.017 af

Pond 1P: Culvert

Peak Elev=150.38' Inflow=0.26 cfs 0.017 af

6.0" Round Culvert n=0.013 L=30.0' S=0.0167 '/' Outflow=0.26 cfs 0.017 af

Total Runoff Area = 0.326 ac Runoff Volume = 0.017 af Average Runoff Depth = 0.61"
100.00% Pervious = 0.326 ac 0.00% Impervious = 0.000 ac

Summary for Subcatchment A: Area

Runoff = 0.26 cfs @ 12.05 hrs, Volume= 0.017 af, Depth= 0.61"

Runoff by SCS TR-20 method, UH=SCS, Time Span= 0.00-40.00 hrs, dt= 0.05 hrs
 Type II 24-hr 1 YEAR Rainfall=2.50"

Area (sf)	CN	Description
14,210	74	>75% Grass cover, Good, HSG C
14,210		100.00% Pervious Area

Tc (min)	Length (feet)	Slope (ft/ft)	Velocity (ft/sec)	Capacity (cfs)	Description
11.5	76	0.0100	0.11		Sheet Flow, Grass Grass: Short n=0.150 P2= 2.60"

Subcatchment A: Area

Hydrograph

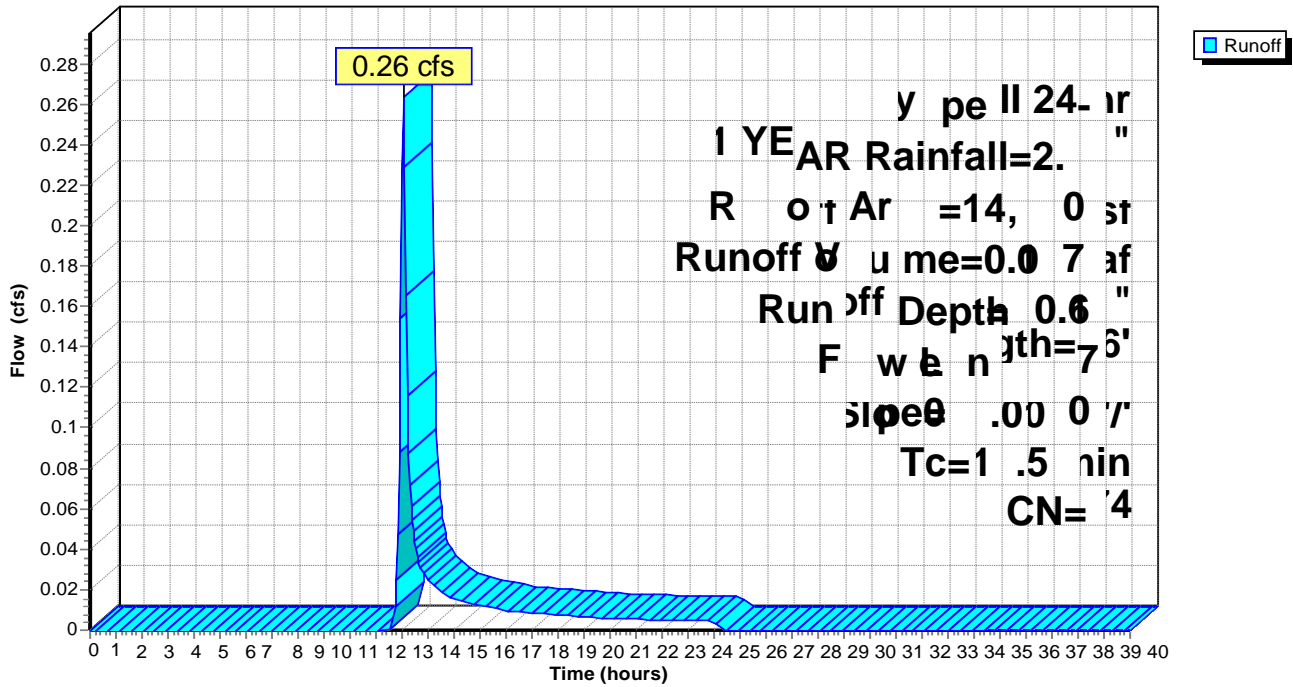

Summary for Reach R1: 48" PIPE

[52] Hint: Inlet/Outlet conditions not evaluated

Inflow Area = 0.326 ac, 0.00% Impervious, Inflow Depth = 0.61" for 1 YEAR event
 Inflow = 0.26 cfs @ 12.05 hrs, Volume= 0.017 af
 Outflow = 0.26 cfs @ 12.05 hrs, Volume= 0.017 af, Atten= 0%, Lag= 0.1 min

Routing by Stor-Ind+Trans method, Time Span= 0.00-40.00 hrs, dt= 0.05 hrs
 Max. Velocity= 7.89 fps, Min. Travel Time= 0.0 min
 Avg. Velocity = 5.97 fps, Avg. Travel Time= 0.1 min

Peak Storage= 1 cf @ 12.05 hrs
 Average Depth at Peak Storage= 0.05'
 Bank-Full Depth= 4.00' Flow Area= 12.6 sf, Capacity= 839.74 cfs

48.0" Round Pipe
 n= 0.015 Brickwork
 Length= 20.0' Slope= 0.4550 '/'
 Inlet Invert= 149.00', Outlet Invert= 139.90'

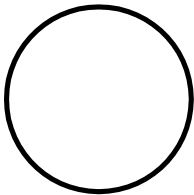

Reach R1: 48" PIPE

Hydrograph

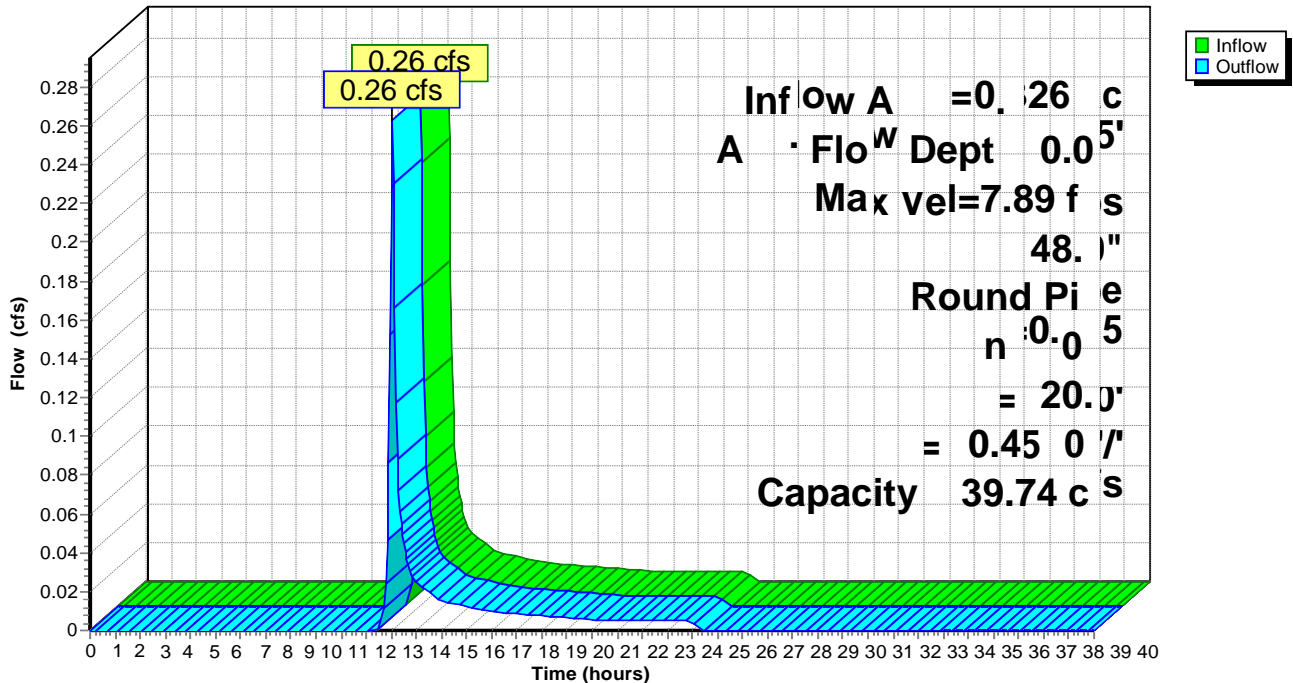

Summary for Pond 1P: Culvert

[57] Hint: Peaked at 150.38' (Flood elevation advised)

Inflow Area = 0.326 ac, 0.00% Impervious, Inflow Depth = 0.61" for 1 YEAR event
 Inflow = 0.26 cfs @ 12.05 hrs, Volume= 0.017 af
 Outflow = 0.26 cfs @ 12.05 hrs, Volume= 0.017 af, Atten= 0%, Lag= 0.0 min
 Primary = 0.26 cfs @ 12.05 hrs, Volume= 0.017 af

Routing by Stor-Ind method, Time Span= 0.00-40.00 hrs, dt= 0.05 hrs
 Peak Elev= 150.38' @ 12.05 hrs

Device	Routing	Invert	Outlet Devices
#1	Primary	150.00'	6.0" Round Culvert L= 30.0' Ke= 0.900 Inlet / Outlet Invert= 150.00' / 149.50' S= 0.0167 '/' Cc= 0.900 n= 0.013, Flow Area= 0.20 sf

Primary OutFlow Max=0.26 cfs @ 12.05 hrs HW=150.38' (Free Discharge)
 ←1=Culvert (Inlet Controls 0.26 cfs @ 1.65 fps)

Pond 1P: Culvert

Hydrograph

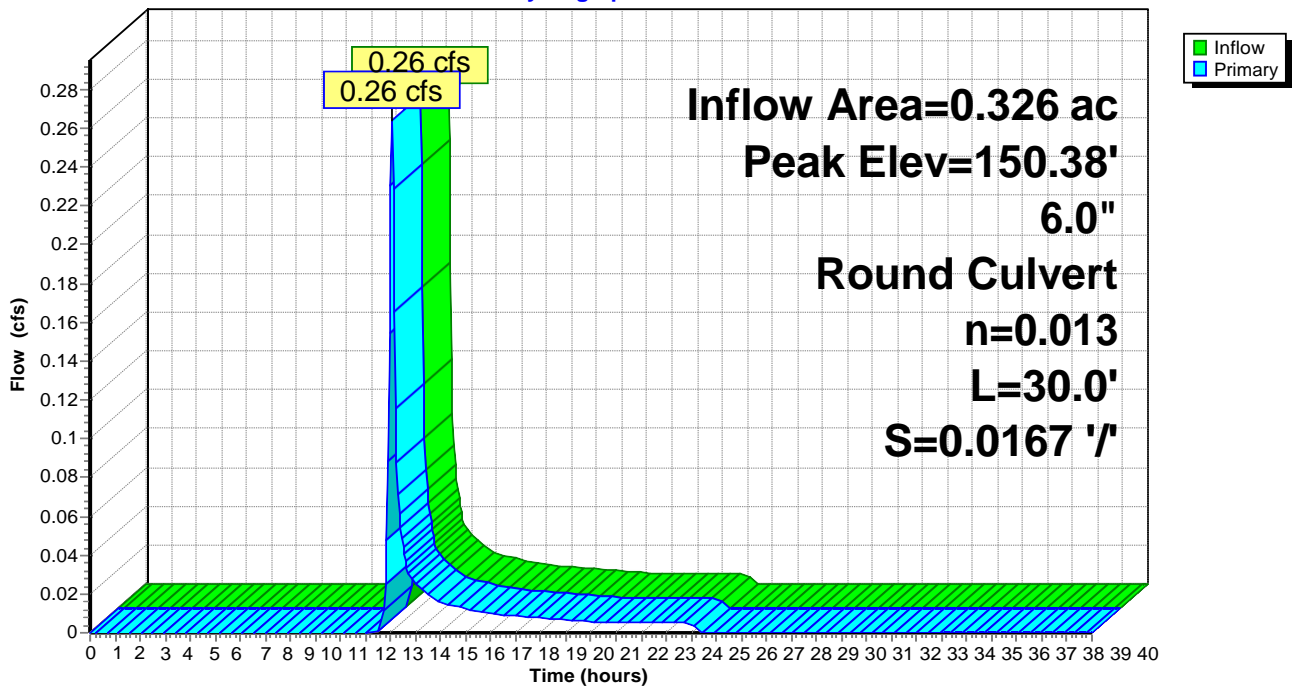

170316-PRE

Type II 24-hr 10 YEAR Rainfall=4.80"

Prepared by Hershberg & Hershberg

Printed 10/20/2017

HydroCAD® 10.00 s/n 03289 © 2012 HydroCAD Software Solutions LLC

Page 10

Time span=0.00-40.00 hrs, dt=0.05 hrs, 801 points

Runoff by SCS TR-20 method, UH=SCS

Reach routing by Stor-Ind+Trans method - Pond routing by Stor-Ind method

Subcatchment A: Area

Runoff Area=14,210 sf 0.00% Impervious Runoff Depth=2.21"

Flow Length=76' Slope=0.0100 '/' Tc=11.5 min CN=74 Runoff=1.04 cfs 0.060 af

Reach R1: 48" PIPE

Avg. Flow Depth=0.10' Max Vel=11.51 fps Inflow=1.04 cfs 0.060 af

48.0" Round Pipe n=0.015 L=20.0' S=0.4550 '/' Capacity=839.74 cfs Outflow=1.04 cfs 0.060 af

Pond 1P: Culvert

Peak Elev=152.18' Inflow=1.04 cfs 0.060 af

6.0" Round Culvert n=0.013 L=30.0' S=0.0167 '/' Outflow=1.04 cfs 0.060 af

Total Runoff Area = 0.326 ac Runoff Volume = 0.060 af Average Runoff Depth = 2.21"
100.00% Pervious = 0.326 ac 0.00% Impervious = 0.000 ac

Summary for Subcatchment A: Area

Runoff = 1.04 cfs @ 12.04 hrs, Volume= 0.060 af, Depth= 2.21"

Runoff by SCS TR-20 method, UH=SCS, Time Span= 0.00-40.00 hrs, dt= 0.05 hrs
 Type II 24-hr 10 YEAR Rainfall=4.80"

Area (sf)	CN	Description
14,210	74	>75% Grass cover, Good, HSG C
14,210		100.00% Pervious Area

Tc (min)	Length (feet)	Slope (ft/ft)	Velocity (ft/sec)	Capacity (cfs)	Description
11.5	76	0.0100	0.11		Sheet Flow, Grass Grass: Short n= 0.150 P2= 2.60"

Subcatchment A: Area

Hydrograph

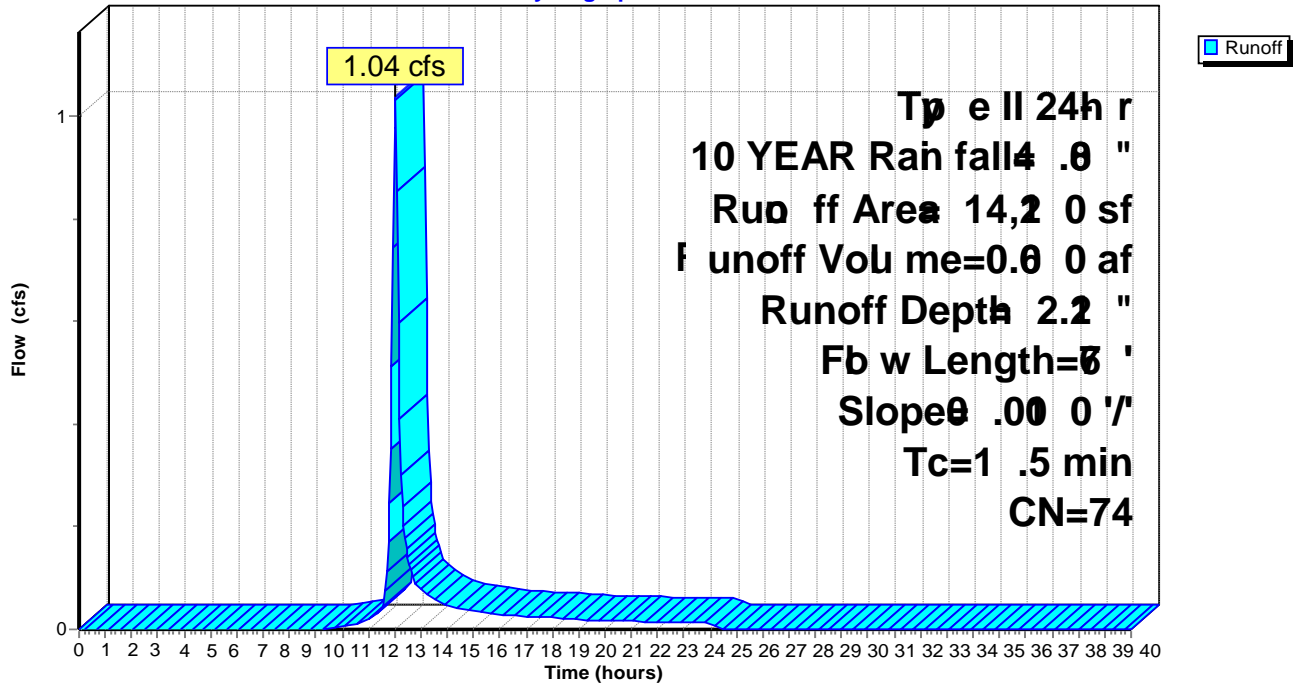

Summary for Reach R1: 48" PIPE

[52] Hint: Inlet/Outlet conditions not evaluated

Inflow Area = 0.326 ac, 0.00% Impervious, Inflow Depth = 2.21" for 10 YEAR event
 Inflow = 1.04 cfs @ 12.04 hrs, Volume= 0.060 af
 Outflow = 1.04 cfs @ 12.04 hrs, Volume= 0.060 af, Atten= 0%, Lag= 0.1 min

Routing by Stor-Ind+Trans method, Time Span= 0.00-40.00 hrs, dt= 0.05 hrs
 Max. Velocity= 11.51 fps, Min. Travel Time= 0.0 min
 Avg. Velocity = 6.09 fps, Avg. Travel Time= 0.1 min

Peak Storage= 2 cf @ 12.04 hrs
 Average Depth at Peak Storage= 0.10'
 Bank-Full Depth= 4.00' Flow Area= 12.6 sf, Capacity= 839.74 cfs

48.0" Round Pipe
 n= 0.015 Brickwork
 Length= 20.0' Slope= 0.4550 '/'
 Inlet Invert= 149.00', Outlet Invert= 139.90'

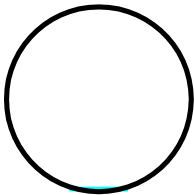

Reach R1: 48" PIPE

Hydrograph

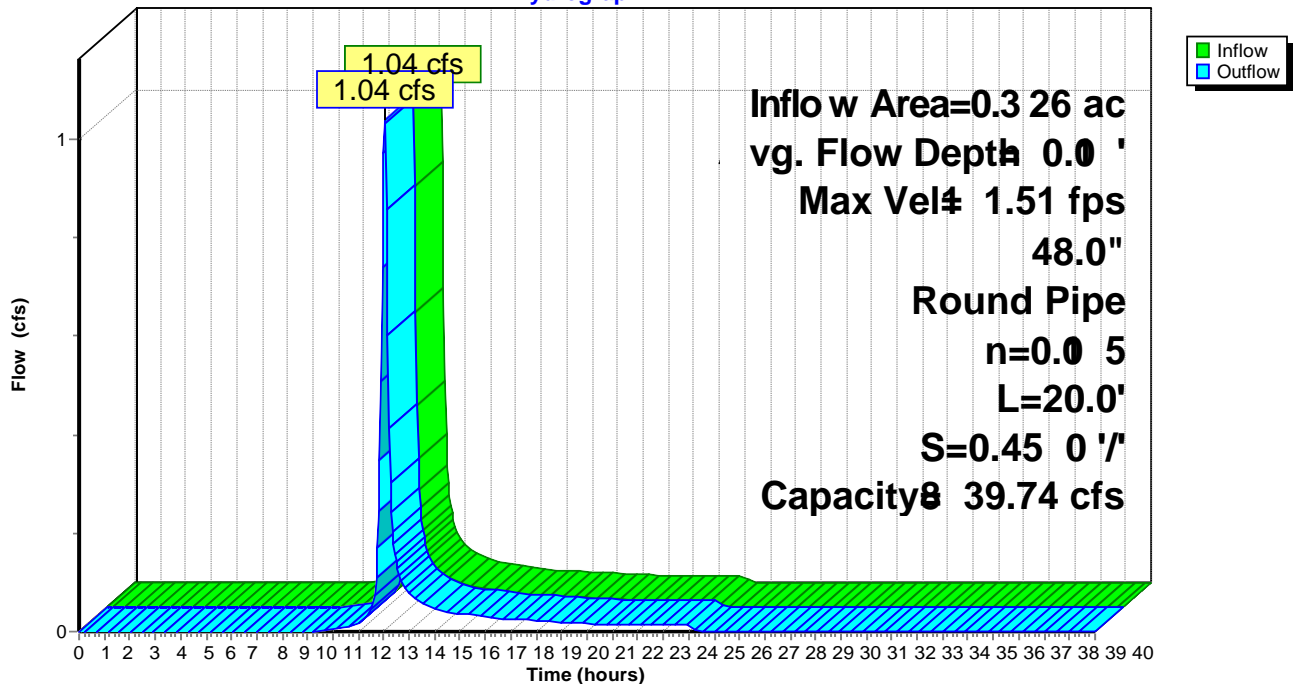

Summary for Pond 1P: Culvert

[57] Hint: Peaked at 152.18' (Flood elevation advised)

Inflow Area = 0.326 ac, 0.00% Impervious, Inflow Depth = 2.21" for 10 YEAR event
 Inflow = 1.04 cfs @ 12.04 hrs, Volume= 0.060 af
 Outflow = 1.04 cfs @ 12.04 hrs, Volume= 0.060 af, Atten= 0%, Lag= 0.0 min
 Primary = 1.04 cfs @ 12.04 hrs, Volume= 0.060 af

Routing by Stor-Ind method, Time Span= 0.00-40.00 hrs, dt= 0.05 hrs
 Peak Elev= 152.18' @ 12.04 hrs

Device	Routing	Invert	Outlet Devices
#1	Primary	150.00'	6.0" Round Culvert L= 30.0' Ke= 0.900 Inlet / Outlet Invert= 150.00' / 149.50' S= 0.0167 '/' Cc= 0.900 n= 0.013, Flow Area= 0.20 sf

Primary OutFlow Max=1.02 cfs @ 12.04 hrs HW=152.10' (Free Discharge)
 ←1=Culvert (Inlet Controls 1.02 cfs @ 5.17 fps)

Pond 1P: Culvert

Hydrograph

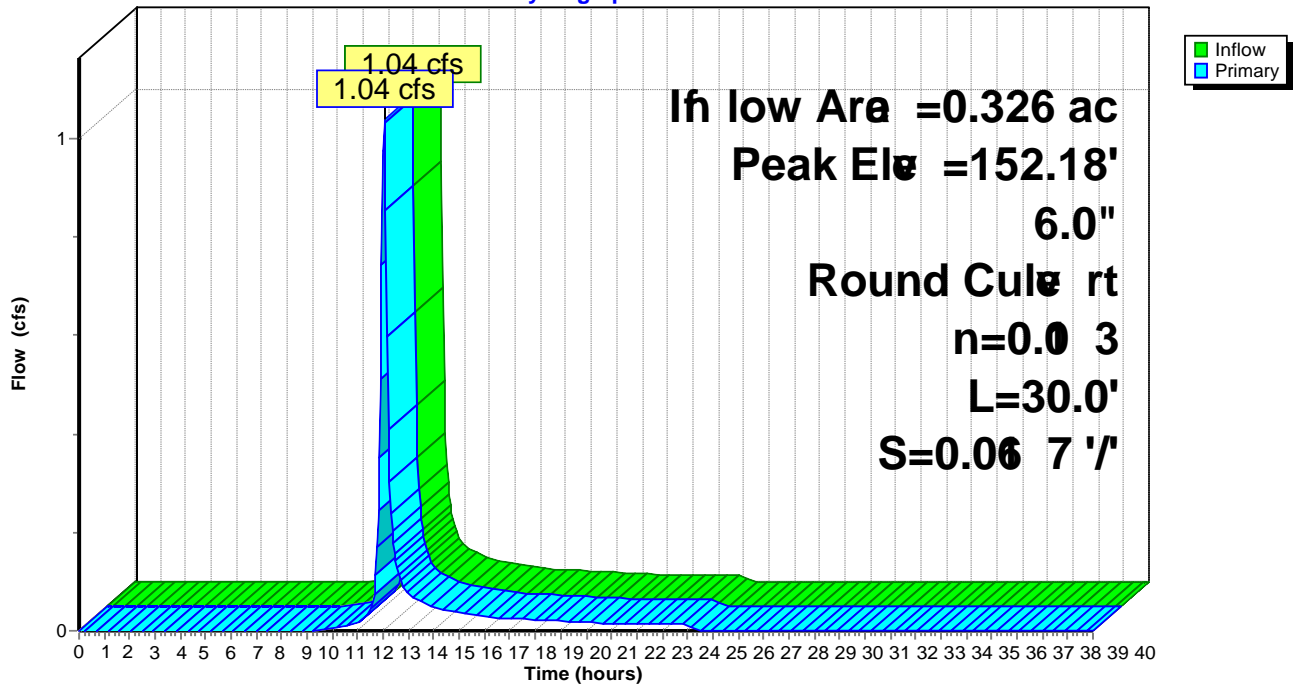

170316-PRE

Type II 24-hr 100 YEAR Rainfall=7.00"

Prepared by Hershberg & Hershberg

Printed 10/20/2017

HydroCAD® 10.00 s/n 03289 © 2012 HydroCAD Software Solutions LLC

Page 14

Time span=0.00-40.00 hrs, dt=0.05 hrs, 801 points

Runoff by SCS TR-20 method, UH=SCS

Reach routing by Stor-Ind+Trans method - Pond routing by Stor-Ind method

Subcatchment A: Area

Runoff Area=14,210 sf 0.00% Impervious Runoff Depth=4.04"

Flow Length=76' Slope=0.0100 '/' Tc=11.5 min CN=74 Runoff=1.89 cfs 0.110 af

Reach R1: 48" PIPE

Avg. Flow Depth=0.14' Max Vel=13.71 fps Inflow=1.89 cfs 0.110 af

48.0" Round Pipe n=0.015 L=20.0' S=0.4550 '/' Capacity=839.74 cfs Outflow=1.89 cfs 0.110 af

Pond 1P: Culvert

Peak Elev=156.66' Inflow=1.89 cfs 0.110 af

6.0" Round Culvert n=0.013 L=30.0' S=0.0167 '/' Outflow=1.89 cfs 0.110 af

Total Runoff Area = 0.326 ac Runoff Volume = 0.110 af Average Runoff Depth = 4.04"
100.00% Pervious = 0.326 ac 0.00% Impervious = 0.000 ac

Summary for Subcatchment A: Area

Runoff = 1.89 cfs @ 12.03 hrs, Volume= 0.110 af, Depth= 4.04"

Runoff by SCS TR-20 method, UH=SCS, Time Span= 0.00-40.00 hrs, dt= 0.05 hrs
 Type II 24-hr 100 YEAR Rainfall=7.00"

Area (sf)	CN	Description
14,210	74	>75% Grass cover, Good, HSG C
14,210		100.00% Pervious Area

Tc (min)	Length (feet)	Slope (ft/ft)	Velocity (ft/sec)	Capacity (cfs)	Description
11.5	76	0.0100	0.11		Sheet Flow, Grass Grass: Short n= 0.150 P2= 2.60"

Subcatchment A: Area

Hydrograph

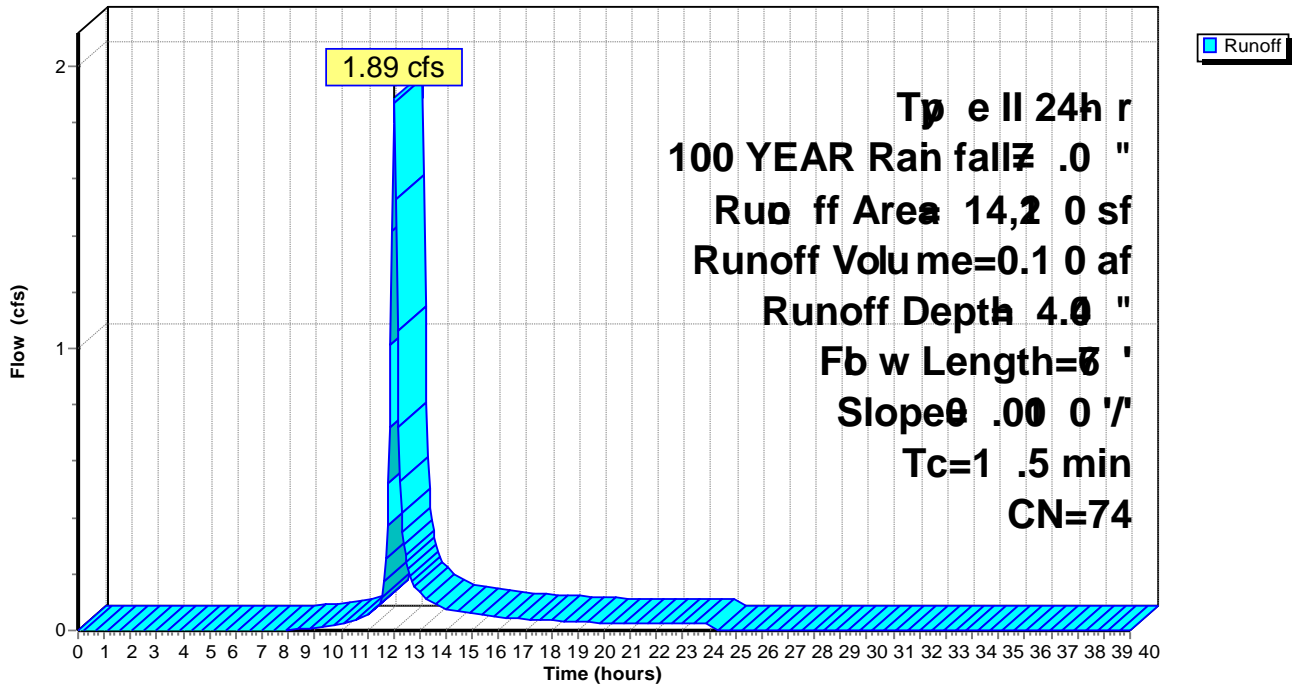

Summary for Reach R1: 48" PIPE

[52] Hint: Inlet/Outlet conditions not evaluated

Inflow Area = 0.326 ac, 0.00% Impervious, Inflow Depth = 4.04" for 100 YEAR event
 Inflow = 1.89 cfs @ 12.03 hrs, Volume= 0.110 af
 Outflow = 1.89 cfs @ 12.03 hrs, Volume= 0.110 af, Atten= 0%, Lag= 0.0 min

Routing by Stor-Ind+Trans method, Time Span= 0.00-40.00 hrs, dt= 0.05 hrs
 Max. Velocity= 13.71 fps, Min. Travel Time= 0.0 min
 Avg. Velocity = 6.18 fps, Avg. Travel Time= 0.1 min

Peak Storage= 3 cf @ 12.03 hrs
 Average Depth at Peak Storage= 0.14'
 Bank-Full Depth= 4.00' Flow Area= 12.6 sf, Capacity= 839.74 cfs

48.0" Round Pipe
 n= 0.015 Brickwork
 Length= 20.0' Slope= 0.4550 '/'
 Inlet Invert= 149.00', Outlet Invert= 139.90'

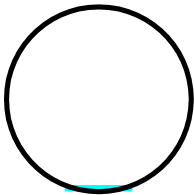

Reach R1: 48" PIPE

Hydrograph

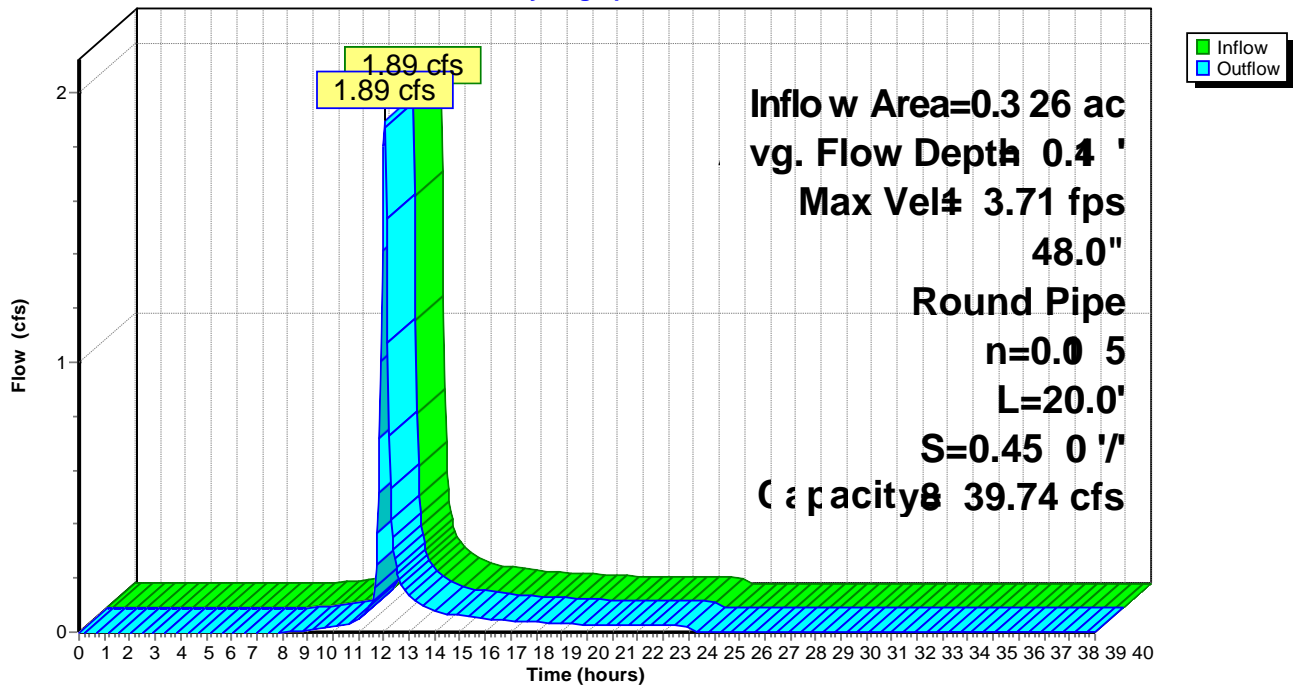

Summary for Pond 1P: Culvert

[57] Hint: Peaked at 156.66' (Flood elevation advised)

Inflow Area = 0.326 ac, 0.00% Impervious, Inflow Depth = 4.04" for 100 YEAR event
 Inflow = 1.89 cfs @ 12.03 hrs, Volume= 0.110 af
 Outflow = 1.89 cfs @ 12.03 hrs, Volume= 0.110 af, Atten= 0%, Lag= 0.0 min
 Primary = 1.89 cfs @ 12.03 hrs, Volume= 0.110 af

Routing by Stor-Ind method, Time Span= 0.00-40.00 hrs, dt= 0.05 hrs
 Peak Elev= 156.66' @ 12.03 hrs

Device	Routing	Invert	Outlet Devices
#1	Primary	150.00'	6.0" Round Culvert L= 30.0' Ke= 0.900 Inlet / Outlet Invert= 150.00' / 149.50' S= 0.0167 1/ S= 0.0167 1/ Cc= 0.900 n= 0.013, Flow Area= 0.20 sf

Primary OutFlow Max=1.85 cfs @ 12.03 hrs HW=156.38' (Free Discharge)
 ←1=Culvert (Inlet Controls 1.85 cfs @ 9.41 fps)

Pond 1P: Culvert

Hydrograph

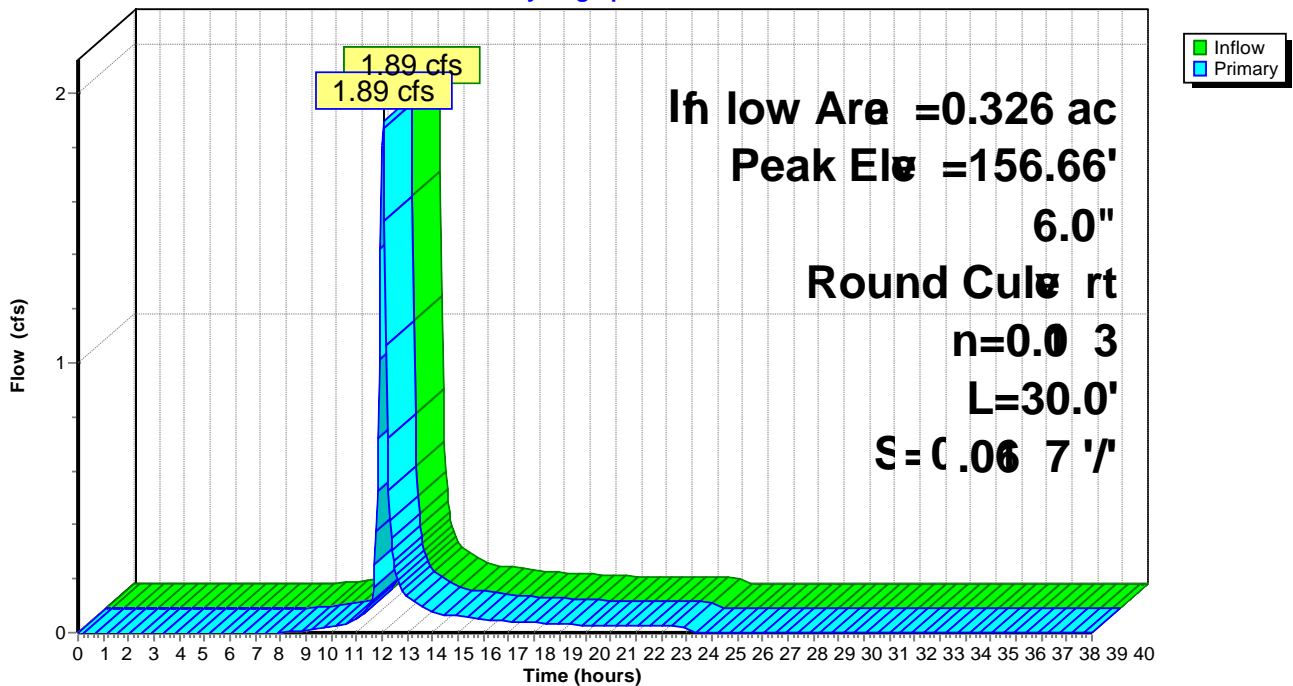

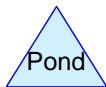
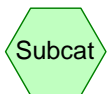
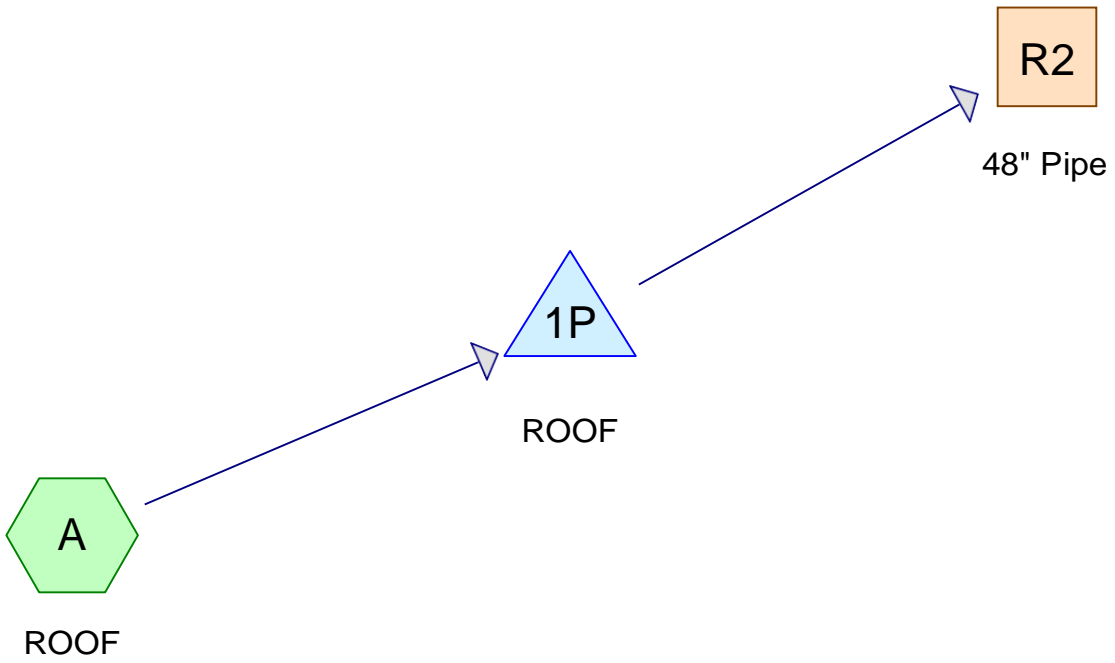

170316-POST

Area Listing (all nodes)

Area (acres)	CN	Description (subcatchment-numbers)
0.326	98	Roofs, HSG A (A)
0.326	98	TOTAL AREA

170316-POST

Soil Listing (all nodes)

Area (acres)	Soil Group	Subcatchment Numbers
0.326	HSG A	A
0.000	HSG B	
0.000	HSG C	
0.000	HSG D	
0.000	Other	
0.326		TOTAL AREA

170316-POST

Ground Covers (all nodes)

HSG-A (acres)	HSG-B (acres)	HSG-C (acres)	HSG-D (acres)	Other (acres)	Total (acres)	Ground Cover	Subcatchment Numbers
0.326	0.000	0.000	0.000	0.000	0.326	Roofs	A
0.326	0.000	0.000	0.000	0.000	0.326	TOTAL AREA	

170316-POST

Prepared by Hershberg & Hershberg
HydroCAD® 10.00 s/n 03289 © 2012 HydroCAD Software Solutions LLC

Printed 10/20/2017
Page 5

Pipe Listing (all nodes)

Line#	Node Number	In-Invert (feet)	Out-Invert (feet)	Length (feet)	Slope (ft/ft)	n	Diam/Width (inches)	Height (inches)	Inside-Fill (inches)
1	R2	149.00	148.90	20.0	0.0050	0.015	48.0	0.0	0.0

170316-POST

Type II 24-hr 1 YEAR Rainfall=2.50"

Prepared by Hershberg & Hershberg

Printed 10/20/2017

HydroCAD® 10.00 s/n 03289 © 2012 HydroCAD Software Solutions LLC

Page 6

Time span=0.00-60.00 hrs, dt=0.05 hrs, 1201 points

Runoff by SCS TR-20 method, UH=SCS

Reach routing by Stor-Ind+Trans method - Pond routing by Stor-Ind method

Subcatchment A: ROOF

Runoff Area=14,210 sf 100.00% Impervious Runoff Depth=2.27"

Flow Length=76' Slope=0.0100 '/' Tc=1.4 min CN=98 Runoff=1.25 cfs 0.062 af

Reach R2: 48" Pipe

Avg. Flow Depth=0.14' Max Vel=1.42 fps Inflow=0.19 cfs 0.062 af

48.0" Round Pipe n=0.015 L=20.0' S=0.0050 '/' Capacity=88.03 cfs Outflow=0.19 cfs 0.062 af

Pond 1P: ROOF

Peak Elev=150.04' Storage=1,331 cf Inflow=1.25 cfs 0.062 af

Outflow=0.19 cfs 0.062 af

Total Runoff Area = 0.326 ac Runoff Volume = 0.062 af Average Runoff Depth = 2.27"
0.00% Pervious = 0.000 ac 100.00% Impervious = 0.326 ac

Summary for Subcatchment A: ROOF

[49] Hint: $T_c < 2dt$ may require smaller dt

Runoff = 1.25 cfs @ 11.90 hrs, Volume= 0.062 af, Depth= 2.27"

Runoff by SCS TR-20 method, UH=SCS, Time Span= 0.00-60.00 hrs, dt= 0.05 hrs
 Type II 24-hr 1 YEAR Rainfall=2.50"

Area (sf)	CN	Description
14,210	98	Roofs, HSG A
14,210		100.00% Impervious Area

Tc (min)	Length (feet)	Slope (ft/ft)	Velocity (ft/sec)	Capacity (cfs)	Description
1.4	76	0.0100	0.89		Sheet Flow, Roof Smooth surfaces n= 0.011 P2= 2.60"

Subcatchment A: ROOF

Hydrograph

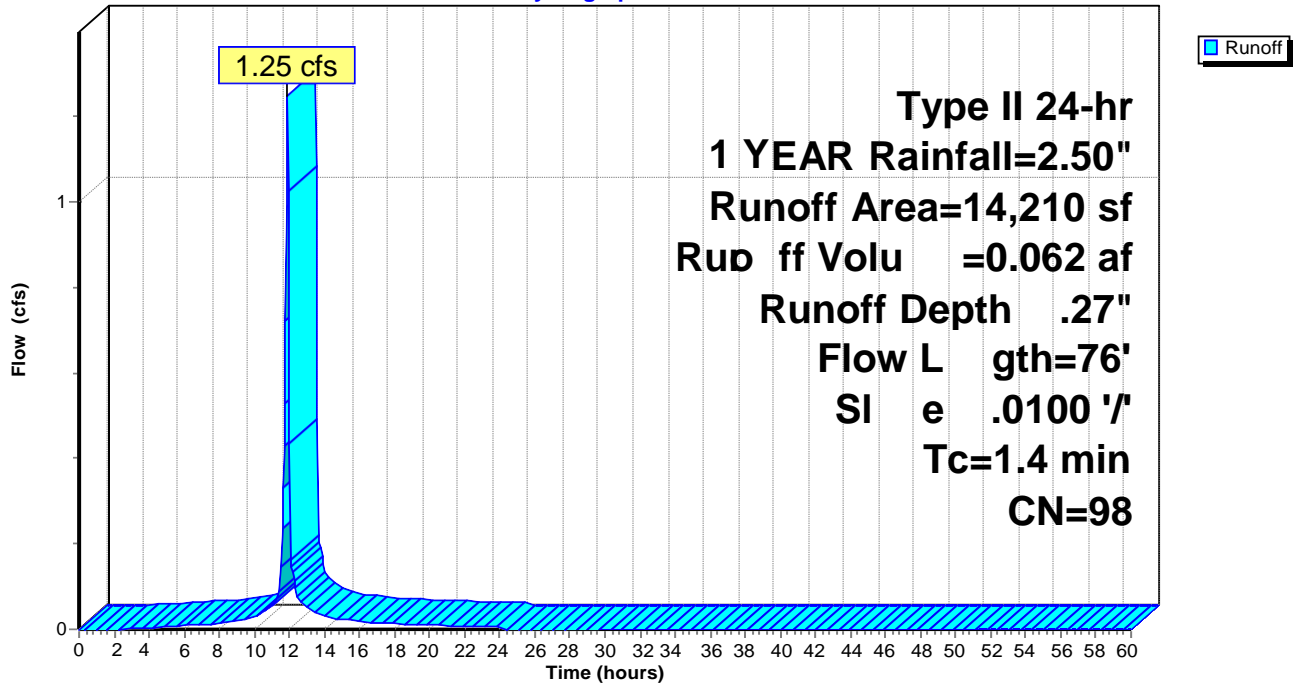

Summary for Reach R2: 48" Pipe

[52] Hint: Inlet/Outlet conditions not evaluated

Inflow Area = 0.326 ac, 100.00% Impervious, Inflow Depth > 2.27" for 1 YEAR event
 Inflow = 0.19 cfs @ 12.06 hrs, Volume= 0.062 af
 Outflow = 0.19 cfs @ 12.07 hrs, Volume= 0.062 af, Atten= 0%, Lag= 0.4 min

Routing by Stor-Ind+Trans method, Time Span= 0.00-60.00 hrs, dt= 0.05 hrs
 Max. Velocity= 1.42 fps, Min. Travel Time= 0.2 min
 Avg. Velocity= 0.69 fps, Avg. Travel Time= 0.5 min

Peak Storage= 3 cf @ 12.07 hrs
 Average Depth at Peak Storage= 0.14'
 Bank-Full Depth= 4.00' Flow Area= 12.6 sf, Capacity= 88.03 cfs

48.0" Round Pipe
 n= 0.015 Brickwork
 Length= 20.0' Slope= 0.0050 '/'
 Inlet Invert= 149.00', Outlet Invert= 148.90'

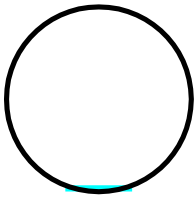

Reach R2: 48" Pipe

Hydrograph

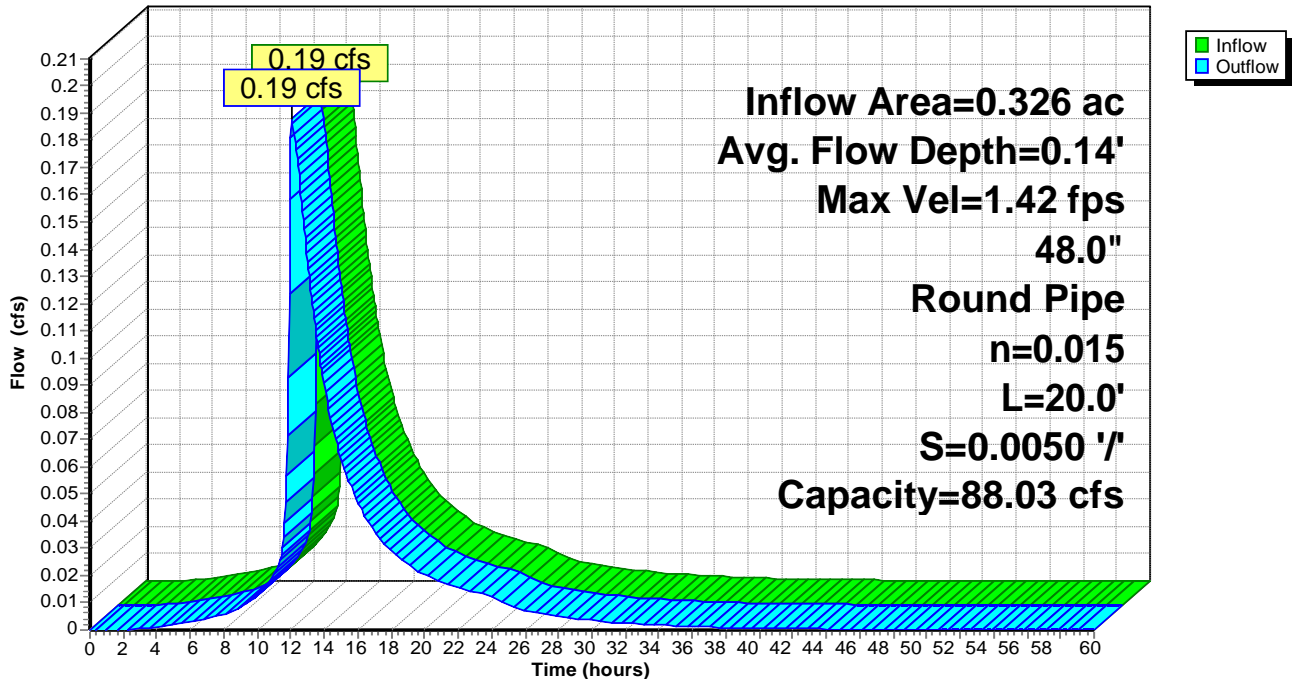

Summary for Pond 1P: ROOF

Inflow Area = 0.326 ac, 100.00% Impervious, Inflow Depth = 2.27" for 1 YEAR event
 Inflow = 1.25 cfs @ 11.90 hrs, Volume= 0.062 af
 Outflow = 0.19 cfs @ 12.06 hrs, Volume= 0.062 af, Atten= 85%, Lag= 9.7 min
 Primary = 0.19 cfs @ 12.06 hrs, Volume= 0.062 af

Routing by Stor-Ind method, Time Span= 0.00-60.00 hrs, dt= 0.05 hrs
 Peak Elev= 150.04' @ 12.06 hrs Surf.Area= 30,866 sf Storage= 1,331 cf

Plug-Flow detention time= 190.2 min calculated for 0.062 af (100% of inflow)
 Center-of-Mass det. time= 191.4 min (945.2 - 753.9)

Volume	Invert	Avail.Storage	Storage Description
#1	150.00'	15,433 cf	Custom Stage Data (Prismatic) Listed below (Recalc)

Elevation (feet)	Surf.Area (sq-ft)	Inc.Store (cubic-feet)	Cum.Store (cubic-feet)
150.00	30,866	0	0
150.50	30,866	15,433	15,433

Device	Routing	Invert	Outlet Devices
#1	Primary	150.00'	3.5" Horiz. roof drain X 7.00 C= 0.600 Limited to weir flow at low heads

Primary OutFlow Max=0.19 cfs @ 12.06 hrs HW=150.04' (Free Discharge)
 ↖ **1=roof drain** (Weir Controls 0.19 cfs @ 0.68 fps)

Pond 1P: ROOF

Hydrograph

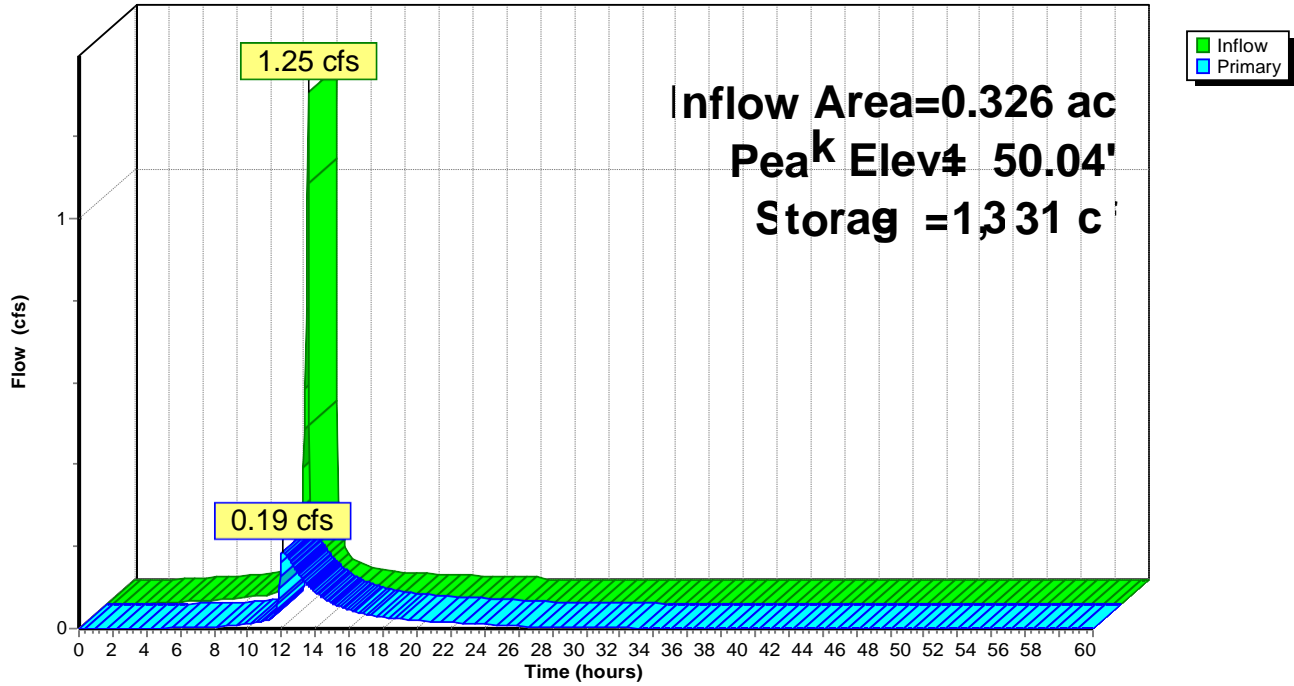

170316-POST

Type II 24-hr 10 YEAR Rainfall=4.80"

Prepared by Hershberg & Hershberg

Printed 10/20/2017

HydroCAD® 10.00 s/n 03289 © 2012 HydroCAD Software Solutions LLC

Page 11

Time span=0.00-60.00 hrs, dt=0.05 hrs, 1201 points

Runoff by SCS TR-20 method, UH=SCS

Reach routing by Stor-Ind+Trans method - Pond routing by Stor-Ind method

Subcatchment A: ROOF

Runoff Area=14,210 sf 100.00% Impervious Runoff Depth=4.56"

Flow Length=76' Slope=0.0100 '/' Tc=1.4 min CN=98 Runoff=2.42 cfs 0.124 af

Reach R2: 48" Pipe

Avg. Flow Depth=0.21' Max Vel=1.87 fps Inflow=0.47 cfs 0.124 af

48.0" Round Pipe n=0.015 L=20.0' S=0.0050 '/' Capacity=88.03 cfs Outflow=0.47 cfs 0.124 af

Pond 1P: ROOF

Peak Elev=150.08' Storage=2,461 cf Inflow=2.42 cfs 0.124 af

Outflow=0.47 cfs 0.124 af

Total Runoff Area = 0.326 ac Runoff Volume = 0.124 af Average Runoff Depth = 4.56"
0.00% Pervious = 0.000 ac 100.00% Impervious = 0.326 ac

Summary for Subcatchment A: ROOF

[49] Hint: $T_c < 2dt$ may require smaller dt

Runoff = 2.42 cfs @ 11.90 hrs, Volume= 0.124 af, Depth= 4.56"

Runoff by SCS TR-20 method, UH=SCS, Time Span= 0.00-60.00 hrs, dt= 0.05 hrs

Type II 24-hr 10 YEAR Rainfall=4.80"

Area (sf)	CN	Description
14,210	98	Roofs, HSG A
14,210		100.00% Impervious Area

Tc (min)	Length (feet)	Slope (ft/ft)	Velocity (ft/sec)	Capacity (cfs)	Description
1.4	76	0.0100	0.89		Sheet Flow, Roof Smooth surfaces n= 0.011 P2= 2.60"

Subcatchment A: ROOF

Hydrograph

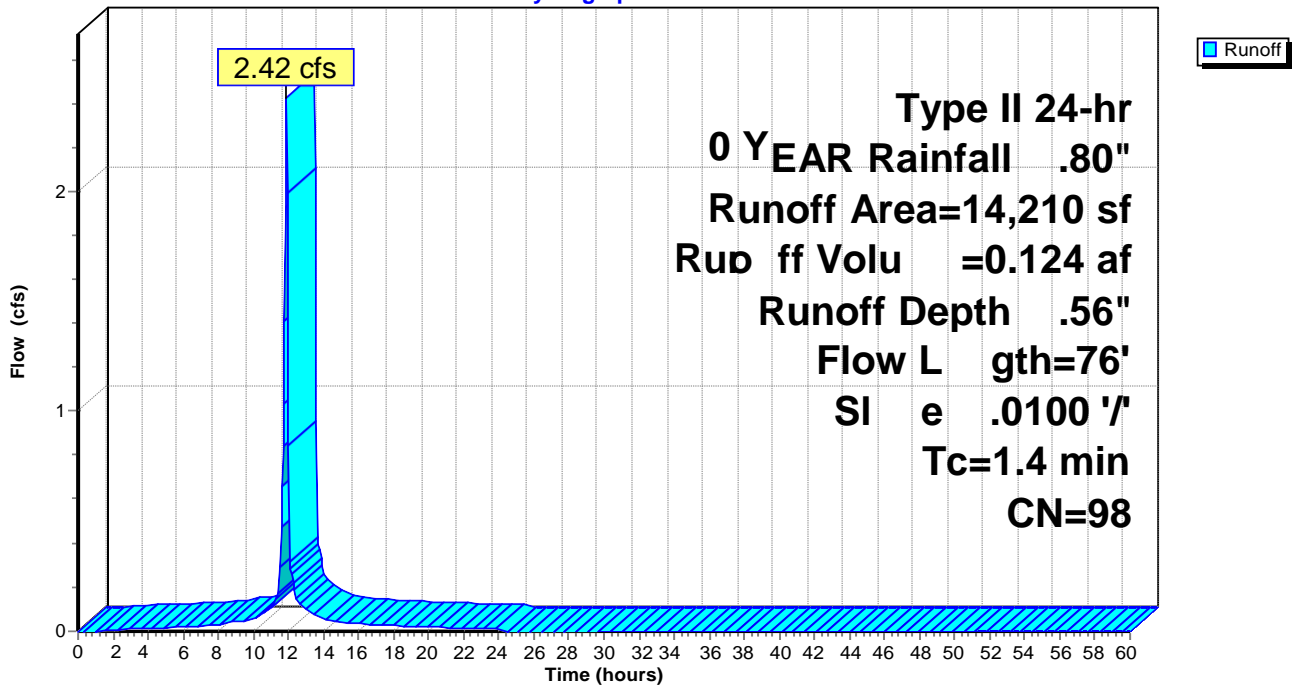

Summary for Reach R2: 48" Pipe

[52] Hint: Inlet/Outlet conditions not evaluated

Inflow Area = 0.326 ac, 100.00% Impervious, Inflow Depth = 4.56" for 10 YEAR event
 Inflow = 0.47 cfs @ 12.05 hrs, Volume= 0.124 af
 Outflow = 0.47 cfs @ 12.05 hrs, Volume= 0.124 af, Atten= 0%, Lag= 0.5 min

Routing by Stor-Ind+Trans method, Time Span= 0.00-60.00 hrs, dt= 0.05 hrs
 Max. Velocity= 1.87 fps, Min. Travel Time= 0.2 min
 Avg. Velocity= 0.75 fps, Avg. Travel Time= 0.4 min

Peak Storage= 5 cf @ 12.05 hrs
 Average Depth at Peak Storage= 0.21'
 Bank-Full Depth= 4.00' Flow Area= 12.6 sf, Capacity= 88.03 cfs

48.0" Round Pipe
 n= 0.015 Brickwork
 Length= 20.0' Slope= 0.0050 '/'
 Inlet Invert= 149.00', Outlet Invert= 148.90'

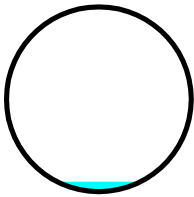

Reach R2: 48" Pipe

Hydrograph

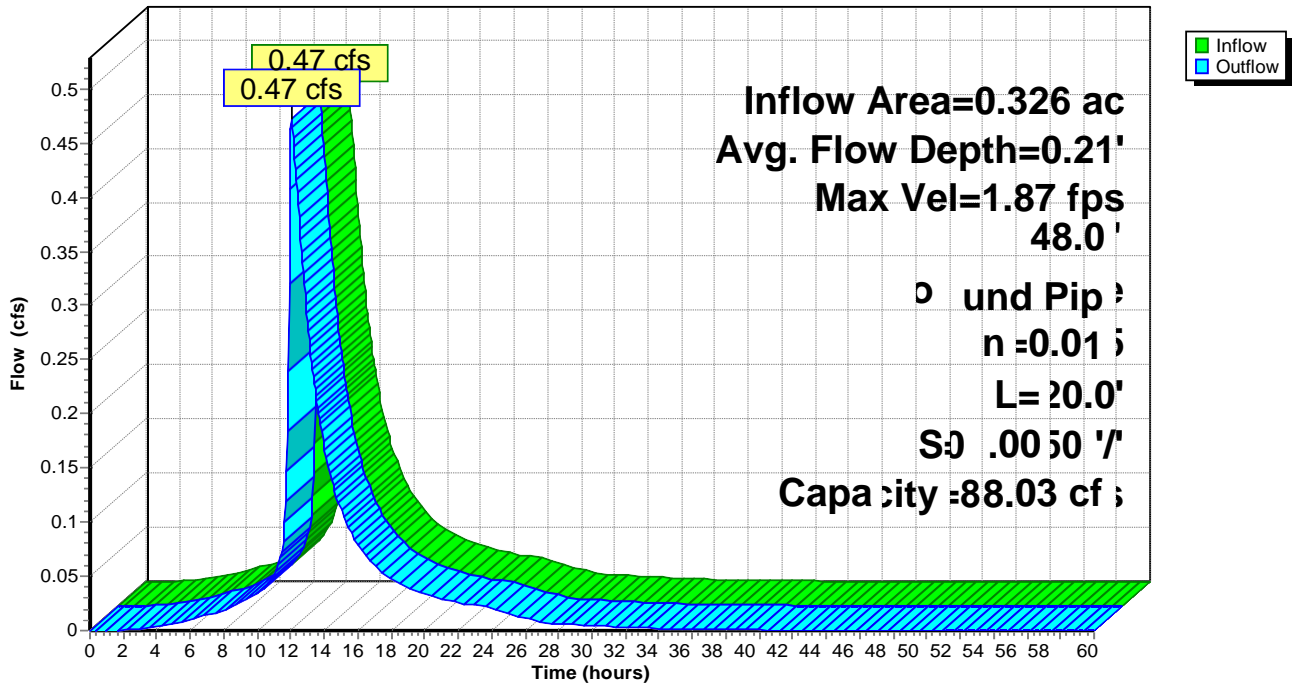

170316-POST

Type II 24-hr 10 YEAR Rainfall=4.80"

Prepared by Hershberg & Hershberg

Printed 10/20/2017

HydroCAD® 10.00 s/n 03289 © 2012 HydroCAD Software Solutions LLC

Page 14

Summary for Pond 1P: ROOF

Inflow Area = 0.326 ac, 100.00% Impervious, Inflow Depth = 4.56" for 10 YEAR event
 Inflow = 2.42 cfs @ 11.90 hrs, Volume= 0.124 af
 Outflow = 0.47 cfs @ 12.05 hrs, Volume= 0.124 af, Atten= 81%, Lag= 8.6 min
 Primary = 0.47 cfs @ 12.05 hrs, Volume= 0.124 af

Routing by Stor-Ind method, Time Span= 0.00-60.00 hrs, dt= 0.05 hrs
 Peak Elev= 150.08' @ 12.05 hrs Surf.Area= 30,866 sf Storage= 2,461 cf

Plug-Flow detention time= 151.8 min calculated for 0.124 af (100% of inflow)
 Center-of-Mass det. time= 153.0 min (893.4 - 740.4)

Volume	Invert	Avail.Storage	Storage Description
#1	150.00'	15,433 cf	Custom Stage Data (Prismatic) Listed below (Recalc)

Elevation (feet)	Surf.Area (sq-ft)	Inc.Store (cubic-feet)	Cum.Store (cubic-feet)
150.00	30,866	0	0
150.50	30,866	15,433	15,433

Device	Routing	Invert	Outlet Devices
#1	Primary	150.00'	3.5" Horiz. roof drain X 7.00 C= 0.600 Limited to weir flow at low heads

Primary OutFlow Max=0.47 cfs @ 12.05 hrs HW=150.08' (Free Discharge)
 ↖**1=roof drain** (Weir Controls 0.47 cfs @ 0.92 fps)

Pond 1P: ROOF

Hydrograph

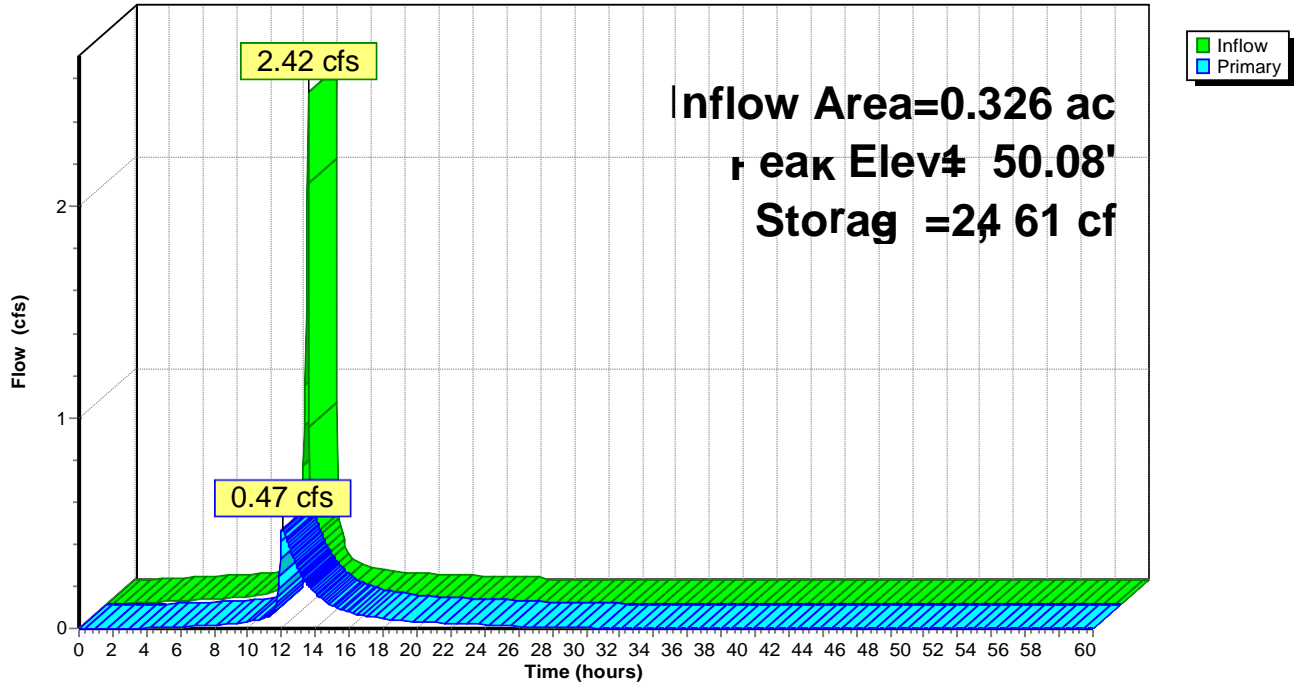

170316-POST

Type II 24-hr 100 YEAR Rainfall=7.00"

Prepared by Hershberg & Hershberg

Printed 10/20/2017

HydroCAD® 10.00 s/n 03289 © 2012 HydroCAD Software Solutions LLC

Page 16

Time span=0.00-60.00 hrs, dt=0.05 hrs, 1201 points

Runoff by SCS TR-20 method, UH=SCS

Reach routing by Stor-Ind+Trans method - Pond routing by Stor-Ind method

Subcatchment A: ROOF

Runoff Area=14,210 sf 100.00% Impervious Runoff Depth=6.76"

Flow Length=76' Slope=0.0100 '/' Tc=1.4 min CN=98 Runoff=3.54 cfs 0.184 af

Reach R2: 48" Pipe

Avg. Flow Depth=0.26' Max Vel=2.15 fps Inflow=0.75 cfs 0.184 af

48.0" Round Pipe n=0.015 L=20.0' S=0.0050 '/' Capacity=88.03 cfs Outflow=0.75 cfs 0.184 af

Pond 1P: ROOF

Peak Elev=150.11' Storage=3,462 cf Inflow=3.54 cfs 0.184 af

Outflow=0.75 cfs 0.184 af

Total Runoff Area = 0.326 ac Runoff Volume = 0.184 af Average Runoff Depth = 6.76"
0.00% Pervious = 0.000 ac 100.00% Impervious = 0.326 ac

Summary for Subcatchment A: ROOF

[49] Hint: $T_c < 2dt$ may require smaller dt

Runoff = 3.54 cfs @ 11.90 hrs, Volume= 0.184 af, Depth= 6.76"

Runoff by SCS TR-20 method, UH=SCS, Time Span= 0.00-60.00 hrs, dt= 0.05 hrs
 Type II 24-hr 100 YEAR Rainfall=7.00"

Area (sf)	CN	Description
14,210	98	Roofs, HSG A
14,210		100.00% Impervious Area

Tc (min)	Length (feet)	Slope (ft/ft)	Velocity (ft/sec)	Capacity (cfs)	Description
1.4	76	0.0100	0.89		Sheet Flow, Roof Smooth surfaces n= 0.011 P2= 2.60"

Subcatchment A: ROOF

Hydrograph

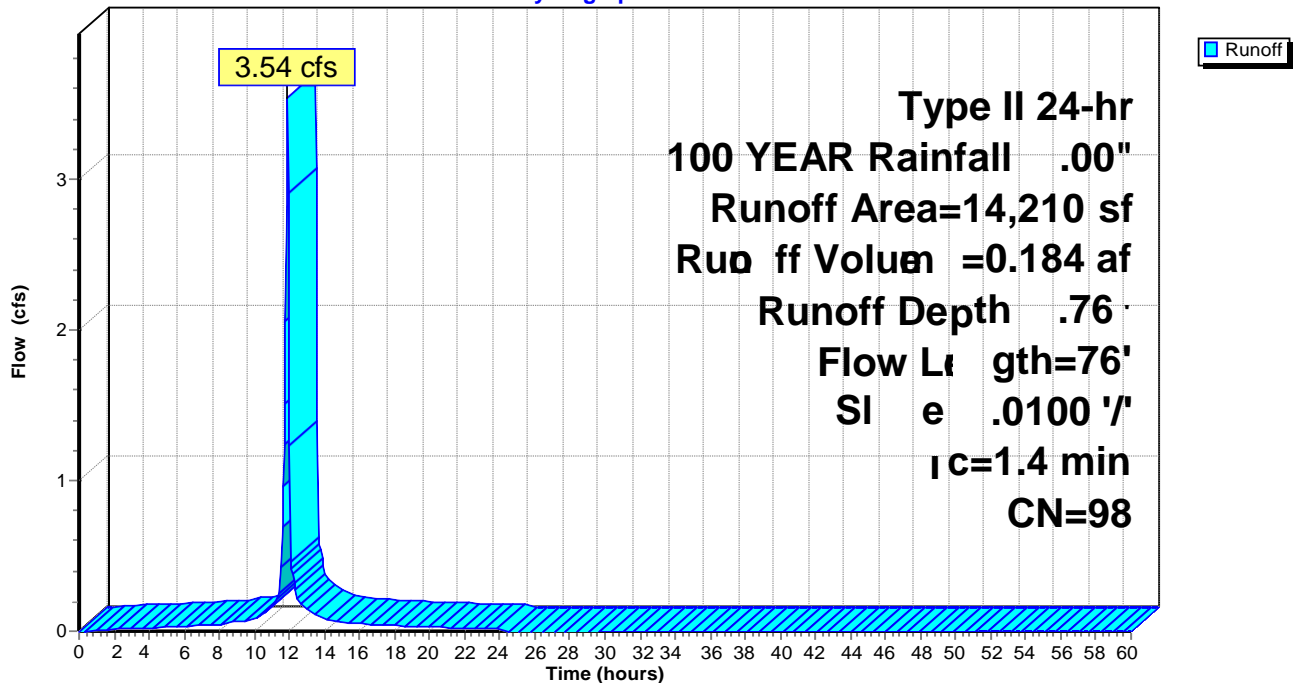

Summary for Reach R2: 48" Pipe

[52] Hint: Inlet/Outlet conditions not evaluated

Inflow Area = 0.326 ac, 100.00% Impervious, Inflow Depth = 6.76" for 100 YEAR event
 Inflow = 0.75 cfs @ 12.04 hrs, Volume= 0.184 af
 Outflow = 0.75 cfs @ 12.05 hrs, Volume= 0.184 af, Atten= 0%, Lag= 0.6 min

Routing by Stor-Ind+Trans method, Time Span= 0.00-60.00 hrs, dt= 0.05 hrs
 Max. Velocity= 2.15 fps, Min. Travel Time= 0.2 min
 Avg. Velocity= 0.79 fps, Avg. Travel Time= 0.4 min

Peak Storage= 7 cf @ 12.00 hrs
 Average Depth at Peak Storage= 0.26'
 Bank-Full Depth= 4.00' Flow Area= 12.6 sf, Capacity= 88.03 cfs

48.0" Round Pipe
 n= 0.015 Brickwork
 Length= 20.0' Slope= 0.0050 '/'
 Inlet Invert= 149.00', Outlet Invert= 148.90'

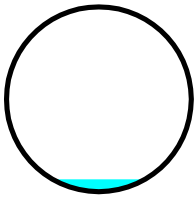

Reach R2: 48" Pipe

Hydrograph

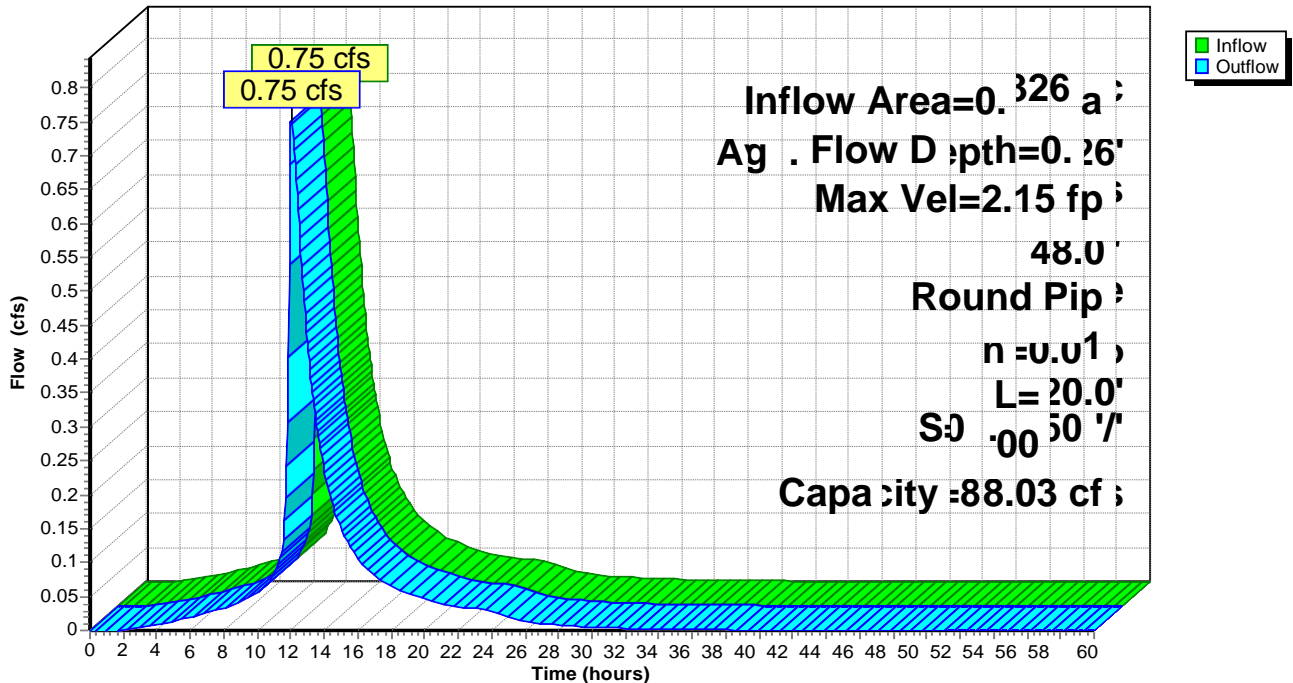

170316-POST

Type II 24-hr 100 YEAR Rainfall=7.00"

Prepared by Hershberg & Hershberg

Printed 10/20/2017

HydroCAD® 10.00 s/n 03289 © 2012 HydroCAD Software Solutions LLC

Page 19

Summary for Pond 1P: ROOF

Inflow Area = 0.326 ac, 100.00% Impervious, Inflow Depth = 6.76" for 100 YEAR event
 Inflow = 3.54 cfs @ 11.90 hrs, Volume= 0.184 af
 Outflow = 0.75 cfs @ 12.04 hrs, Volume= 0.184 af, Atten= 79%, Lag= 8.1 min
 Primary = 0.75 cfs @ 12.04 hrs, Volume= 0.184 af

Routing by Stor-Ind method, Time Span= 0.00-60.00 hrs, dt= 0.05 hrs
 Peak Elev= 150.11' @ 12.04 hrs Surf.Area= 30,866 sf Storage= 3,462 cf

Plug-Flow detention time= 133.3 min calculated for 0.184 af (100% of inflow)
 Center-of-Mass det. time= 134.4 min (868.9 - 734.5)

Volume	Invert	Avail.Storage	Storage Description
#1	150.00'	15,433 cf	Custom Stage Data (Prismatic) Listed below (Recalc)

Elevation (feet)	Surf.Area (sq-ft)	Inc.Store (cubic-feet)	Cum.Store (cubic-feet)
150.00	30,866	0	0
150.50	30,866	15,433	15,433

Device	Routing	Invert	Outlet Devices
#1	Primary	150.00'	3.5" Horiz. roof drain X 7.00 C= 0.600 Limited to weir flow at low heads

Primary OutFlow Max=0.75 cfs @ 12.04 hrs HW=150.11' (Free Discharge)
 ↖ **1=roof drain** (Orifice Controls 0.75 cfs @ 1.61 fps)

Pond 1P: ROOF

Hydrograph

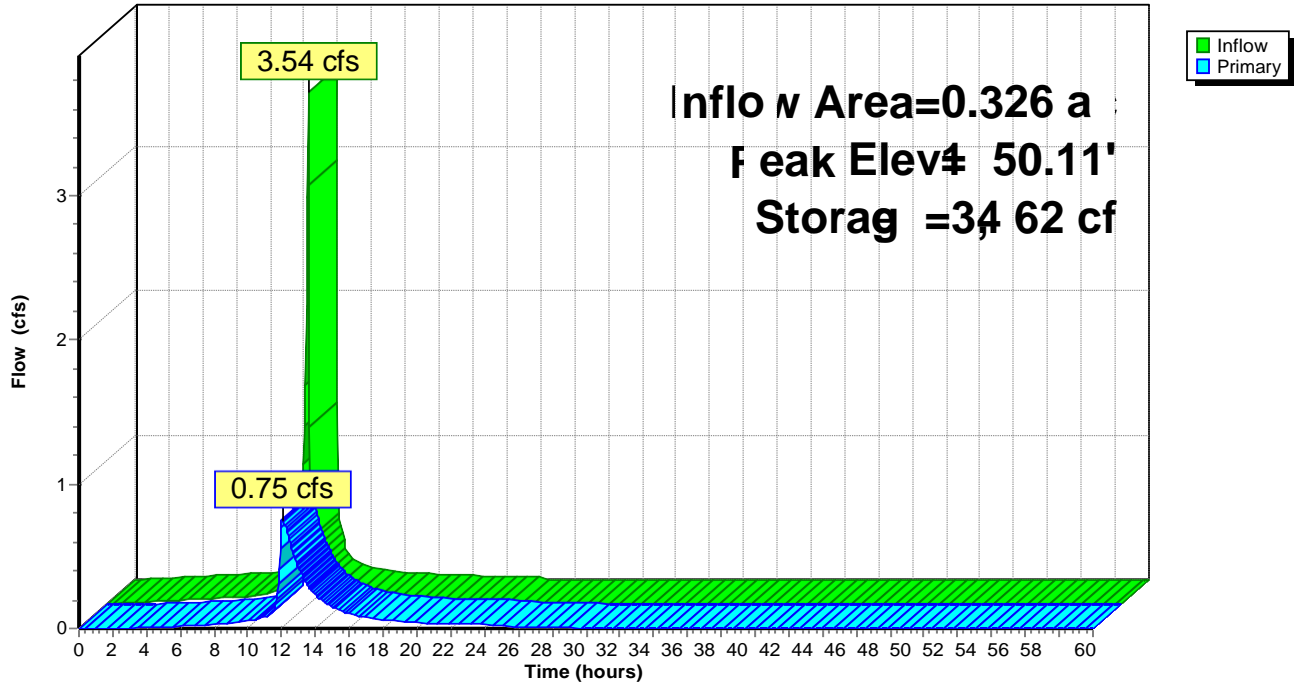

APPENDIX #2

MAINTENANCE PLAN

Facility Owner (Responsible Party):
Harmony Mill South, LLC

The facility owner will be responsible to provide capital funding for this facility. The source will be from infrastructure funds set aside for construction. On an annual basis the responsible party will budget funds to fund the annual operating and maintenance costs. The facility owner must maintain all drainage facilities, stormwater quantity control facilities and all stormwater quality control facilities in accordance with approved plans and with this maintenance manual. Complete inspection form and retain with SWMR. Inspection may be performed by a Qualified Inspector or a Qualified Professional.

The elements of this SWMR which require inspection include:

Roof Drains – Conduct a monthly and quarterly inspection.

Annual inspection shall determine whether the benchmarks listed in the checklist are met.

Operation, Maintenance and Management Inspection Checklist (Complete in 1 Page)

Project: 90 State Street Apartment Conversion
Location: 90 State Street
City of Albany, Albany County, NY
Date: _____
Time: _____
Inspector: _____

MAINTENANCE ITEM	SATISFACTORY(S)/ UNSATISFACTORY(U)	COMMENTS
------------------	---------------------------------------	----------

1. Cleanout (Check Monthly)

Roof areas clean of debris (S) (U) _____

Area around Roof Drains is clean (S) (U) _____

2. Pipe Connections (Check Quarterly)

Verify Pipes remain connected (S) (U) _____

Identify any leaks and repair (S) (U) _____

5. Overall Function of System (Check Annually)

Verify that roof drains are functioning (S) (U) _____

Comments:

Actions to be Taken:

APPENDIX #3

MAINTENANCE AGREEMENT

STORMWATER MANAGEMENT SYSTEM MAINTENANCE AGREEMENT
90 State Street Apartment Conversion

THIS AGREEMENT ("Agreement") is made and entered into on the day of , 2017, by and between Harmony Mill South, LLC, with an address _____(hereinafter referred to as the "Facility Owner"), and

CITY OF ALBANY, a municipal corporation with an address at 24 Eagle Street, Albany, New York 12207 (hereinafter referred to as the "City").

WITNESSETH:

WHEREAS, the Facility Owner is the owner of the subject parcel of land in the City of Albany, County of Albany and State of New York as more particularly located at 90 State Street, Albany New York.

WHEREAS, the City and the Facility Owner desire that the stormwater management system be built in accordance with the approved project documents and thereafter be maintained, cleaned, repaired, replaced and continued in perpetuity in order to ensure optimum performance of the components; and

WHEREAS, the City has requested this legally binding and enforceable maintenance agreement from the Facility Owner; and

WHEREAS, the Facility Owner is representing the following design documents, with their City approved revisions, as containing all necessary information to construct, operate and maintain the stormwater management system for the lifetime of the facility:

a. Plan submitted to the City representing a stormwater management system including stormwater collection, conveyance and storage using structures designed and specified by Hershberg & Hershberg, Consulting Engineers, sealed by Daniel R. Hershberg, P.E., as the Engineer of Record. The plan sheets showing features associated with the stormwater management system are listed below.

<u>Sheet#</u>	<u>Date</u>	<u>Drawing Title</u>
C-1	9/27/2017	EXISTING CONDITIONS AND SEWER CONNECTION PERMIT PLAN

b. *STORM WATER MANAGEMENT REPORT (SWMR)*, 90 State Street Apartment Conversion prepared by Hershberg & Hershberg, Consulting Engineers and Land Surveyors , dated October 4, 2017

IN CONSIDERATION THEREOF, the parties agree as follow:

1. The Facility Owner shall be responsible for maintaining the storm water facility in a manner to prevent silt from becoming tributary to the City's storm water drainage system.

2. Operation and maintenance, including inspection and cleaning of the full storm water drainage system, shall be the responsibility of the Facility Owner.
3. In the event the Facility Owner fails to maintain the system in a manner to control storm water the City may order the system cleaned and bill the Facility Owner the full cost of this work at labor cost (direct labor plus 50% salary burden) and materials (at cost) if work is performed by the Department of Water & Water Supply; or the cost of a subcontractor plus 10% of the subcontractor's bill if the Department of Water & Water Supply obtains a subcontractor to perform the work. Invoices are payable to the Department of Water & Water Supply within ten (10) business days from the date of invoice. In the event payment for costs is not received within said ten (10) day period, the Department of Water & Water Supply shall have the right to file a lien in the amount of the invoice, together with reasonable costs of collection incurred in connection therewith, against the property of the Facility Owner.
4. The City has the right to access the premises for periodic inspections and to perform any maintenance of the stormwater system.
5. The Facility Owner shall disclose this Agreement to any successor or assignees in interest.
6. This Agreement is binding on the Facility Owner and any successor or assignees in interest hereof.
7. Facility Owner agrees to defend, indemnify, and save harmless the CITY and its officers, employees and agents, from and against all claims, actions, causes of action, injuries, damages, losses, liabilities, and expenses (including, without limitation, reasonable attorney's fees and court costs) arising out of, or in consequence of, any negligent or intentional act or omission of Facility Owner to the extent of its or their responsibility for such claims, actions, causes of action, injuries, damages, losses, liabilities, and expenses. The provisions of this Article shall survive any termination or expiration of this Agreement.

[Signatures on next page]

APPENDIX #4

ROOF DRAIN DETAILS

RAINTROL[®] ROOF DRAINS



**control flow to sewers
reduce material and labor cost**

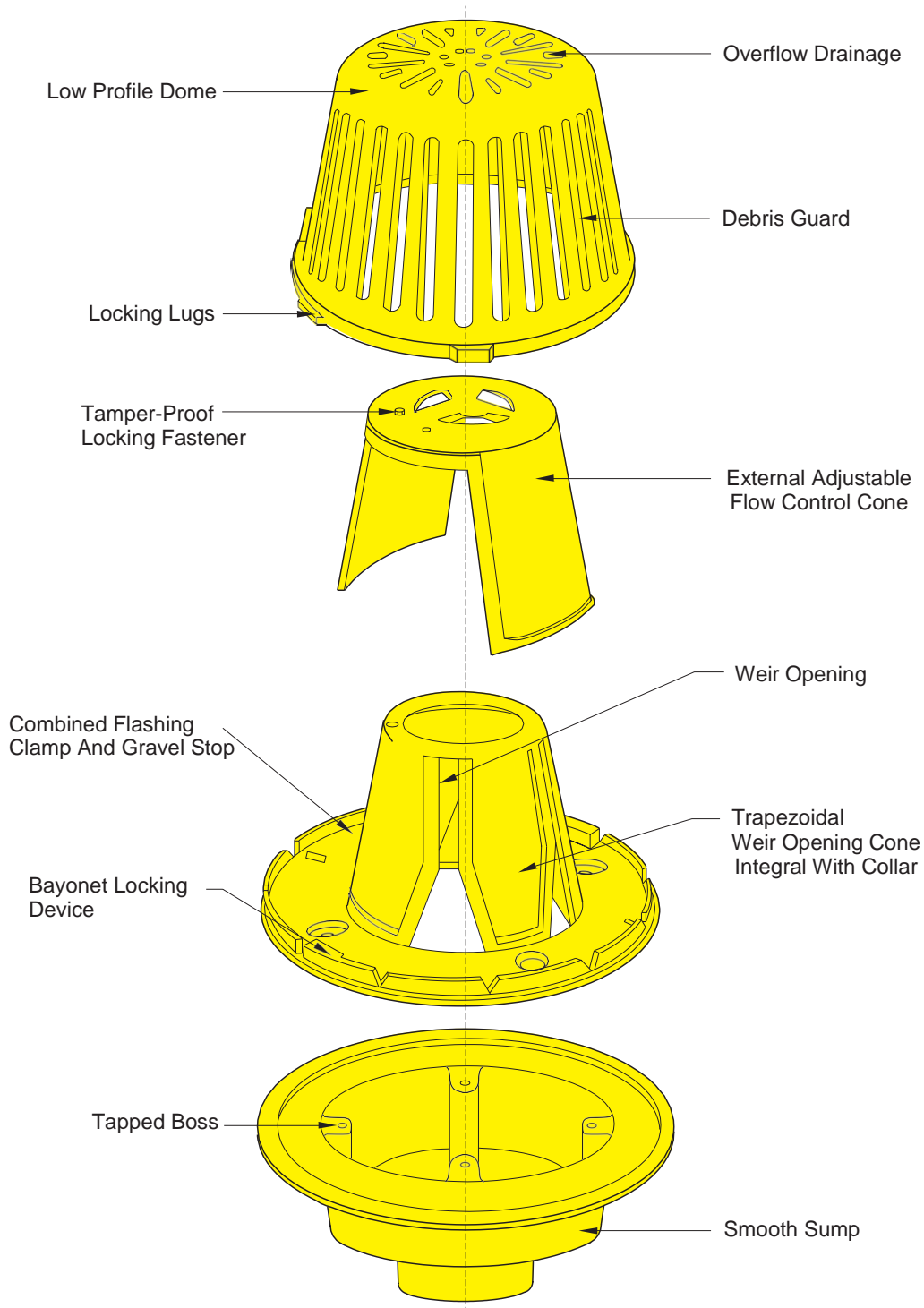

Fig. 1085

RAINTROL[®] FLOW CONTROL DRAIN

The RAINTR[®] roof drain was developed to offer certain advantageous features. Drains, leaders, storm sewers, etc., can be economically sized by controlling the flow of water. This will reflect in significant cost savings, both in material and labor. In addition, by controlling the drain rate, existing facilities can be utilized without overloading, thus, new construction can be undertaken and tied into the present storm drains.

To accomplish the above, the RAINTR[®] drain retains water on the roof. The water is allowed to build up to a predetermined height while the excess is drained off at a known maximum rate. The amount of net build-up is a function of rainfall intensity, time, roof area and drain flow rate. Also note that the flow rate is a function of the build-up or head of water, and not the height of the weir. As an example, water at a 2" depth will flow through either the three inch or six inch high weir at the same rate.

The area rating, flow rate and drain down time are given for various locations, consistent with the rainfall data for the localities. The data has been established for over 200 localities. Use of this data and tables will allow the engineer to lay out an efficient roof drainage system which will result in significant economies. Local codes must be observed to avoid conflict and approval problems.

THE AREA RATING IS THE MAXIMUM AREA WHICH CAN BE HANDLED BY ONE WEIR OPENING. The corresponding flow rate and drain down time are also given. Data is presented for four

conditions of roof slope and four return periods. This provides data for sixteen conditions for each locality. In cases where the area rating would exceed 25,000 sq. ft., the rating is limited to 25,000 sq. ft. with a resulting lower flow rate and drain down time. Depth or build-up, the other limit upon which the table data is based, is as follows: 3" depth for flat roof, 4" for 2" rise, 5" for 4" rise and 6" for 6" rise.

DATA DERIVATIONS

The data presented is the result of extensive computer processing. Rainfall information obtained from isopluvial maps was computer matched with the flow characteristics of the weir. The results were computer plotted and tabulated in the final pages of tables.

The Weather Bureau Technical Bulletin No. 40, contains the isopluvials which provide the information for the Weiss Equations of Rainfall Intensity. This is more representative than other data available for design purposes. It also covers all areas, not just point locations. The weir equations were developed from test data. When the two equations are solved simultaneously, the area ratings in the tables are produced. Because of the methods employed, extreme accuracy was realized. Fig. 1 is an example of an isopluvial map. Cities along the same isopluvial will have similar rainfall. This allows use of the data for locations which are not listed.

100-YEAR 1-HOUR RAINFALL (INCHES)

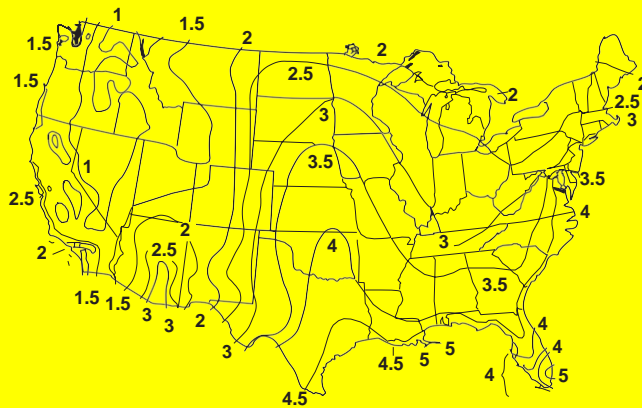

Fig. 1

ROOF TYPES

The roof to be drained may vary from flat to a slope of 6" rise. Rise is measured, vertically from the low point or valley to the high point or ridge. (Refer to Fig. 2 below.)

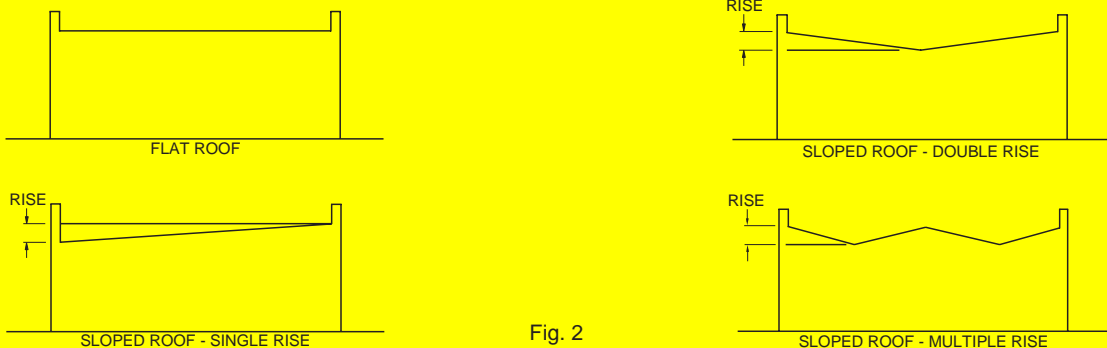

Fig. 2

RAINTROL® SPECIFICATIONS

The RAINTRÖL® drain is offered in two basic designs. The three inch high weir is principally for flat roofs. Though this may be used on sloped roofs, the limited factor is the build up which can not exceed 3". The second design is the six inch weir which can be used on all roofs up to and including a sloped roof with a 6" rise.

NOTE: The roof drains are supplied in increments of weir openings. They are shipped from the factory with the correct weir openings in accordance with the specifications.

However, should some requirements or conditions change, the drain can be adjusted. Vandal proof fasteners prevent unauthorized tampering with the setting.

Included in this section are tables of data for a number of localities. For locations not listed, use values for similar or nearby locations. For specific conditions which require more information, contact Jay R. Smith Mfg. Co.®, Montgomery, Alabama.

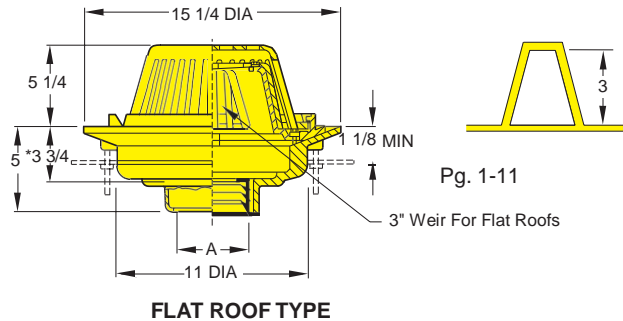

Fig. 1083BOTTOM OUTLET
Fig. 1088SIDE OUTLET

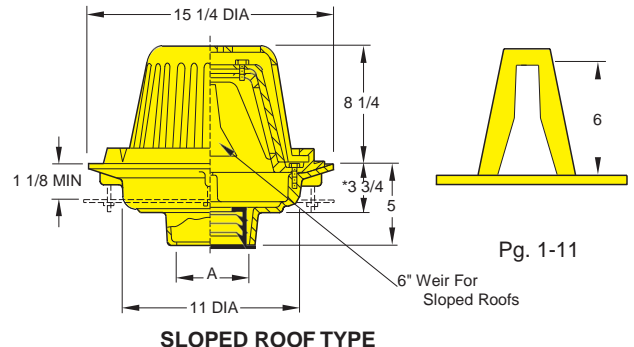

Fig. 1085BOTTOM OUTLET
Fig. 1089SIDE OUTLET

*This Dimension to Internal
Stop of Speedi-Set Gasket.

DRAIN SYSTEMS

The engineer should lay out the roof drain system consistent with the structural design strength of the roof. Normally for a flat roof with a 30 lb. sq. ft. design load, the water depth or build-up would be limited to 3". This will keep the load down to approximately 15 lbs. per square foot. For sloped roofs, the allowed water depth can be greater, but only to the point where the stresses will be within the design limitations. This will be up to the discretion of the engineer.

The roof drainage design can be based on a number of factors. The prime consideration could be economy, using minimum leaders and storm sewers. The allowable roof load or build-up could limit the design. Or possibly, drain down time could be the limiting design criteria. In any case, knowing the maximum flow rates, which are controlled, the engineer can properly size leaders and storm sewers economically consistent with his selected design criteria.

DESIGN CONSIDERATIONS

When designing the roof drain system, the engineer must remember that the roof is being utilized as a temporary reservoir to retain some water. Flashing and waterproofing should be high enough to prevent any leakage. The engineer must also provide adequate strength for structural safety. In addition, the following considerations should be observed:

- On all roofs, use minimum of two drains, if possible.
- On larger roofs, use a greater number of drains as dictated by design layout.
- Limit roof area to 25,000 sq. ft. per weir opening.
- Recommended maximum distance from roof edge to drain is 50 ft. (flat roofs).
- Recommended maximum distance from end of valley to drain is 50 ft. (sloped roofs).
- Recommended maximum distance between drains is 200 ft.
- Provide adequate flashing at parapets, openings, walls, joints, etc.
- Limit parapet walls or provide overflow scuppers. These should be located at the anticipated maximum water depth (build-up). If located in a higher position which could result in a greater flow rate, piping must be sized accordingly.
- Consider wind effect in locating the drains, and the number of drains.
- Possible roof deflection due to load. This could create low spots and adversely affect drainage and/or structural safety.

These are not absolute requirements, but are suggestions to be considered. The final design is at the discretion of the design engineer and should be consistent with the roof requirements.

SPECIFYING AND SIZING

A convenient worksheet (Form No. 2052) is available for sizing and determining RAINTROL® requirements. Refer to page 19 for sample.

Specifying can be done quickly and easily.

1. Determine roof area to be drained. Each area that is bounded by expansion joints, ridges and any enclosure is considered a separate roof area.
2. Divide the roof area by the area rating from the Table of Area Ratings (Table 1) to obtain the total number of weir openings.
3. Determine the number of roof drains. This is determined by the engineer and/or roof layout, using the above design consideration as a guide.
4. Divide the number of drains into the number of weir openings to obtain the number of weir openings per drain. It is not necessary that all drains have the same number of weir openings. As an example, a roof may require eight weir openings, but only six drains. In this case, four drains could have one weir opening and two drains would have two weir openings.

NOTE: There is a minimum of one weir opening per drain.

Table 1, from which the area rating is selected, also lists the corresponding flow rate and drain down time. With this data, the engineer can select the proper leader and storm sewer to accommodate the flow (Table 3). Scupper or overflow protection must be set at the depth corresponding to the flow rate (Tables 1 and 2). This would limit the potential build-up, flow rate and roof loading. The weir height is the maximum potential build-up. If the scuppers are set at a higher level, the potential build-up would be greater. Leaders and storm sewers would have to be sized for the higher flow rates which correspond to the greater build-up. Also, a greater load might be placed on the roof. Refer to Table 3 on page 1-30 for allowable flow rates. Select leaders and storm sewers, which will accommodate the maximum potential flow.

Local codes may be the determining criteria and deviation must be approved.

TABLES

Table 1 on pages 11 thru 15 is the area rating table for one weir and contains the principal data. It is arranged in alphabetical order by states and cities. The data is divided according to roof type. Example: Flat, 2" 4" or 6" rise. Then four return periods are listed under each roof type. Each block shows three values. The top figure is the area rating, the lower left is the maximum flow rate for the particular area, and the lower right figure gives the corresponding drain down time. The drain down time is based on draining from the maximum depth to a depth of one half inch, which is the practical minimum. (Refer to Fig. 3 below).

For values not shown in Table 1, straight line interpolation will give acceptable figures. Using this table will provide practical solutions. For necessary data not listed, the factory should be contacted. The limits on which Table 1 is based are allowable build-up and maximum area. The build-up limit is 3" for flat roofs, 4" for 2" rise, 5" for 4" rise and 6" for 6"

rise. The area ratings are the square foot areas that will produce the above build-ups. However, if the area rating would exceed 25,000 sq. ft., the area rating was limited to 25,000 and the corresponding maximum flow rate and drain down time recorded. The corresponding build-up can be obtained from Table 2 on page 1-30. Interpolate between values shown when intermediate values are desired.

Table 2 lists flow rates for various heads in 1 inch increments.

Table 3 lists the allowable flow rates for various pipe sizes. Rates are given for vertical leaders, and horizontal storm drains installed at three different slopes. These values are consistent with the National Plumbing Code, and values obtained using Mannings formula.

EXPLANATION OF AREA RATING TABLE 1

TYPE ROOF >	FLAT	
	AREA RATING SQ. FT.	
RETURN PERIOD >	FLOW G.P.M.	DRA HR
	10 Yr.	25 Yr.
BIRMINGHAM	7500	4200
	28 15	28 9
DOTHAN	4200	2600
	28 9	28
HUNTSVILLE	11000	
	28 22	
MOBILE		

Labels in diagram:
 - Roof Type: points to TYPE ROOF >
 - Frequency of Storm Return, Read Across: points to RETURN PERIOD >
 - City: points to BIRMINGHAM, DOTHAN, HUNTSVILLE, MOBILE
 - State: points to ALABAMA
 - Flow Rate in Gal. Per Min.: points to FLOW G.P.M.
 - Drain Down Time in Hours: points to DRA HR
 - Area Ratings in Sq. Ft.: points to AREA RATING SQ. FT.
 - Heading Block For Data Arrangement: points to the top-right corner of the table grid.

Fig. 3

AREA RATING TABLE 1 (Continued)

	TYPE ROOF >	FLAT				2" RISE				4" RISE				6" RISE											
		AREA RATING SQ. FT.								AREA RATING SQ. FT.								AREA RATING SQ. FT.							
		FLOW G.P.M.		DRAIN DOWN HRS.		FLOW G.P.M.		DRAIN DOWN HRS.		FLOW G.P.M.		DRAIN DOWN HRS.		FLOW G.P.M.		DRAIN DOWN HRS.									
RETURN PERIOD>	10 Yr.	25 Yr.	50 Yr.	100 Yr.	10 Yr.	25 Yr.	50 Yr.	100 Yr.	10 Yr.	25 Yr.	50 Yr.	100 Yr.	10 Yr.	25 Yr.	50 Yr.	100 Yr.									
MICHIGAN	KALAMAZOO	25000 24 46	24900 28 50	15100 28 31	9500 28 19	25000 31 35	25000 36 38	24000 39 39	15100 39 24	25000 40 25	25000 44 28	25000 47 29	20400 49 25	25000 48 20	25000 53 22	25000 56 24	25000 60 25								
	MARQUETTE	25000 21 42	25000 25 47	25000 27 49	19800 28 40	25000 28 32	25000 31 35	25000 34 37	25000 37 39	25000 36 23	25000 40 25	25000 42 27	25000 45 28	25000 43 18	25000 47 20	25000 51 21	25000 54 23								
	SAGINAW	25000 22 43	25000 25 47	25000 28 50	16300 28 33	25000 29 33	25000 32 36	25000 35 38	25000 38 40	25000 37 23	25000 41 26	25000 44 28	25000 47 29	25000 45 19	25000 50 21	25000 53 22	25000 56 23								
	SAULT STE. MARIE	25000 18 39	25000 21 43	25000 24 46	25000 26 48	25000 25 29	25000 28 32	25000 31 34	25000 33 36	25000 33 21	25000 37 23	25000 39 25	25000 42 26	25000 40 17	25000 44 19	25000 47 20	25000 50 21								
	TRAVERSE CITY	25000 21 42	25000 25 47	25000 27 49	19300 28 39	25000 28 32	25000 32 35	25000 34 37	25000 37 39	25000 37 23	25000 40 25	25000 43 27	25000 46 29	25000 44 19	25000 48 20	25000 51 22	25000 55 23								
MINNESOTA	AUSTIN	23300 28 47	10700 28 22	6600 28 13	4400 28 9	25000 36 39	17100 39 28	10600 39 17	6900 39 11	25000 44 28	22600 49 27	13700 49 17	9200 49 11	25000 53 22	25000 59 25	17500 60 18	11300 60 11								
	DULUTH	25000 24 47	22800 28 46	13800 28 28	8900 28 18	25000 32 35	25000 36 39	21800 39 35	14100 39 23	25000 40 25	25000 45 28	25000 48 30	18600 49 23	25000 48 20	25000 53 22	25000 57 24	23800 60 24								
	MINNEAPOLIS	25000 27 49	13400 28 27	8100 28 16	5200 28 11	25000 34 37	21400 39 34	12700 39 21	8100 39 13	25000 43 27	25000 48 30	17000 49 21	11000 49 13	25000 52 22	25000 57 24	21700 60 22	13600 60 14								
MISS.	JACKSON	5700 28 12	3400 28 7	2500 28 5	1900 28 4	8900 39 14	5300 39 9	3900 39 6	2900 39 5	11700 49 14	6900 49 8	5000 49 6	3800 49 5	14500 60 15	8500 60 9	6100 60 6	4600 60 5								
	GREENVILLE	6200 28 13	3600 28 7	2600 28 5	1900 28 4	9800 39 16	5600 39 9	4000 39 6	2900 39 5	12700 49 15	7300 49 9	5200 49 6	3900 49 5	15900 60 16	9000 60 9	6400 60 6	4700 60 5								
	GULFPORT	2400 28 5	1600 28 3	1300 28 3	1000 28 2	3600 39 6	2500 39 4	1900 39 3	1600 39 3	4800 49 6	3300 49 4	2600 49 3	2100 49 3	5800 60 6	3900 60 4	3100 60 3	2600 60 3								
MISSOURI	COLUMBIA	12300 28 25	6100 28 12	4000 28 8	2700 28 5	19500 39 31	9500 39 15	6200 39 10	4200 39 7	25000 49 30	12500 49 15	8200 49 10	5600 49 7	25000 58 24	15700 60 16	10100 60 10	6900 60 7								
	KIRKSVILLE	14200 28 29	6900 28 14	4400 28 9	3000 28 6	22600 39 36	10900 39 18	7000 39 11	4600 39 8	25000 48 30	14300 49 17	9200 49 11	6200 49 8	25000 57 24	17900 60 18	11400 60 11	7500 60 8								
	SPRINGFIELD	8700 28 18	4600 28 9	3000 28 6	2100 28 4	13700 39 22	7100 39 11	4700 39 8	3300 39 5	17800 49 22	9300 49 11	6300 49 8	4400 49 5	22600 60 23	11500 60 12	7600 60 8	5300 60 5								
	ST. LOUIS	13600 28 28	7200 28 15	4700 28 10	3300 28 7	21500 39 35	11200 39 18	7400 39 12	5100 39 8	25000 48 30	14600 49 18	9800 49 12	6800 49 8	25000 57 24	18600 60 19	12100 60 12	8200 60 8								
MONTANA	BILLINGS	25000 15 34	25000 19 39	25000 21 43	25000 24 46	25000 23 26	25000 26 30	25000 28 32	25000 31 34	25000 30 19	25000 34 21	25000 37 23	25000 39 25	25000 36 15	25000 41 17	25000 44 19	25000 47 20								
	BUTTE	25000 12 28	25000 15 33	25000 17 37	25000 19 40	25000 20 23	25000 22 26	25000 24 28	25000 26 30	25000 27 16	25000 30 19	25000 32 20	25000 34 22	25000 32 13	25000 36 15	25000 39 16	25000 41 17								
	GLENDALE	25000 19 40	25000 23 45	25000 26 49	25000 28 40	25000 26 30	25000 31 34	25000 34 37	25000 37 39	25000 35 22	25000 39 25	25000 43 27	25000 46 29	25000 43 18	25000 48 20	25000 52 22	25000 55 23								
	GREAT FALLS	25000 15 34	25000 18 39	25000 21 42	25000 23 45	25000 22 26	25000 25 29	25000 27 32	25000 30 34	25000 30 18	25000 33 21	25000 36 22	25000 38 24	25000 35 15	25000 40 17	25000 43 18	25000 46 19								
	WAVRE	25000 17 36	25000 20 42	25000 23 45	25000 26 48	25000 24 27	25000 27 31	25000 30 34	25000 33 36	25000 31 19	25000 35 22	25000 38 24	25000 41 26	25000 37 16	25000 42 18	25000 46 19	25000 49 21								
	MISSOULA	25000 13 30	25000 16 35	25000 18 38	25000 20 41	25000 20 23	25000 23 26	25000 25 29	25000 26 31	25000 27 17	25000 30 19	25000 32 20	25000 35 22	25000 32 14	25000 36 15	25000 39 16	25000 42 18								
NEBRASKA	CHADRON	25000 21 43	25000 26 48	23100 28 47	12000 28 24	25000 28 32	25000 33 36	25000 36 39	19700 39 32	25000 37 24	25000 42 26	25000 45 28	25000 49 30	25000 45 19	25000 51 21	25000 55 23	25000 59 25								
	GRAND ISLAND	25000 28 50	9000 28 18	4100 28 8	2000 28 4	25000 38 36	13900 39 22	6500 39 10	3300 39 5	25000 44 28	18800 49 23	8800 49 11	4400 49 5	25000 54 23	23800 60 14	10700 60 11	5300 60 5								
	LINCOLN	16700 28 34	6400 28 13	3500 28 7	2100 28 4	25000 38 40	10400 39 17	5600 39 9	3400 39 5	25000 47 29	13600 49 17	7500 49 9	4400 49 5	25000 56 24	17200 60 17	9200 60 9	5600 60 6								
	NORTH PLATTE	25000 25 47	15100 28 31	6200 28 13	2700 28 5	25000 33 36	23700 39 38	9900 39 16	4300 39 7	25000 42 27	25000 48 30	13000 49 16	5600 49 7	25000 51 22	25000 58 24	16400 60 16	6800 60 7								
	OMAHA	16500 28 33	6700 28 14	3900 28 8	2400 28 5	25000 38 40	11000 39 18	6300 39 10	3800 39 6	25000 47 29	14200 49 17	8000 49 10	5100 49 6	25000 56 24	18300 60 18	10100 60 10	6300 60 6								
NEVADA	LAS VEGAS	25000 13 28	25000 15 34	25000 17 37	25000 20 41	25000 20 23	25000 22 26	25000 24 28	25000 27 31	25000 27 16	25000 30 19	25000 33 20	25000 35 22	25000 32 13	25000 36 15	25000 39 16	25000 42 18								
	RENO WIN-	25000 17 37	25000 20 42	25000 23 45	25000 26 48	25000 23 27	25000 26 31	25000 29 33	25000 32 35	25000 30 19	25000 34 21	25000 36 23	25000 39 25	25000 35 15	25000 40 17	25000 43 18	25000 46 20								
	NEMUCCA	25000 10 21	25000 12 26	25000 13 29	25000 14 32	25000 17 18	25000 18 21	25000 20 23	25000 21 25	25000 22 13	25000 25 15	25000 27 16	25000 28 18	25000 27 11	25000 30 12	25000 32 13	25000 34 14								
N.H.	BERLIN	25000 27 50	16000 28 32	11100 28 22	8000 28 16	25000 34 37	25000 38 40	17300 39 28	12300 39 20	25000 41 26	25000 46 29	22900 49 28	15900 49 19	25000 49 21	25000 54 23	25000 58 24	20800 60 21								
	PORTSMOUTH	22600 28 46	12400 28 25	8600 28 17	6100 28 12	25000 36 38	19900 39 32	13300 39 21	9500 39 15	25000 43 27	25000 49 30	18200 49 21	12100 49 15	25000 51 22	25000 57 24	22300 60 22	15600 60 16								
NEW JERSEY	ATLANTIC CITY	11500 28 23	5800 28 12	3900 28 8	2700 28 6	18600 39 30	9300 39 15	6100 39 10	4200 39 7	24500 49 30	12100 49 15	8000 49 10	5600 49 7	25000 58 24	15100 60 15	9900 60 10	6800 60 7								
	NEWARK	14900 28 30	7700 28 16	5200 28 11	3600 28 7	24000 39 39	12200 39 20	8100 39 13	5600 39 9	25000 47 29	15800 49 19	10400 49 13	7300 49 9	25000 56 23	19800 60 20	12900 60 13	9000 60 9								
	TRENTON	14200 28 29	7200 28 15	4700 28 10	3200 28 7	22900 39 37	11200 39 18	7400 39 12	5000 39 8	25000 48 29	14700 49 18	9600 49 12	6600 49 8	25000 56 24	18600 60 19	11900 60 12	8000 60 8								
NEW MEXICO	ALBUQUERQUE	25000 15 34	25000 19 39	25000 21 43	25000 24 46	25000 23 26	25000 26 30	25000 28 32	25000 31 35	25000 31 19	25000 34 21	25000 37 23	25000 40 25	25000 37 15	25000 41 17	25000 44 19	25000 48 20								
	ALAMOGORDO	25000 17 36	25000 20 42	25000 23 45	25000 26 48	25000 24 28	25000 28 32	25000 31 34	25000 34 37	25000 32 20	25000 36 23	25000 39 25	25000 42 27	25000 39 16	25000 44 19	25000 48 20	25000 51 22								
	FARMINGTON	25000 15 34	25000 19 40	25000 22 43	25000 24 46	25000 23 27	25000 26 30	25000 29 33	25000 31 35	25000 31 19	25000 35 22	25000 37 24	25000 40 25	25000 38 16	25000 42 18	25000 45 19	25000 48 20								
	ROSWELL	25000 22 43	25000 27 49	18600 28 34	10500 28 21	25000 29 33	25000 34 37	25000 37 39	16900 39 27	25000 37 23	25000 42 27	25000 46 29	22500 49 27	25000 45 19	25000 51 21	25000 55 23	25000 59 25								
NEW YORK	ALBANY	25000 26 48	17600 28 36	11200 28 23	7500 28 15	25000 33 36	25000 38 40	17400 39 28	11700 39 19	25000 41 26	25000 46 29	23													

MAP POCKET #1

**EXISTING CONDITIONS AND SEWER
CONNECTION PERMIT PLAN**

